

Rapid charging solutions. High-power, automated connections.

Connections for life | E-Mobility

EN



E-MOBILITY

We accelerate the net-zero transition for industrial mobility.



At Stäubli, we develop high-performing solutions to meet exceptionally high requirements and extreme environmental conditions. Effective charging solutions for e-mobility in industrial applications are no exception. In 2010, we developed the very first Quick Charging Connector (QCC) and

the technology has continued to evolve since. As long-standing collaborative partners in the commercial vehicle, mobile machinery, rail and maritime sectors, we always think ahead when designing connectors for future-proof mobility.



Reliable



Efficient



Safe

Built to perform under harsh conditions.

In industries that never sleep, e-mobility charging systems must be robust, flexible, safe and provide powerful energy transmission even under extreme environmental conditions. With our comprehensive expertise and portfolio of high-quality components, Stäubli solutions meet the most demanding requirements and deliver top performance in challenging environments.

Our QCC automated rapid charging systems provide battery-electric trucks, AGVs, mo-

bile machinery, railcars and vessels maximum power in the shortest possible time. Stäubli electrical connectors deliver efficiency, safety and durability – anytime, anywhere. Distinguished by its robust construction and maintenance-friendly design, QCC sets the course for the future of e-mobility in terms of economic efficiency and reliability.



QCC OVERVIEW

Achieve zero downtime. Reliable, automated charging.

Whether used on land, at sea or on rails: Our QCC fully automated rapid charging system offers you flexibility, reliability and safety you can count on. We help keep your operations moving.

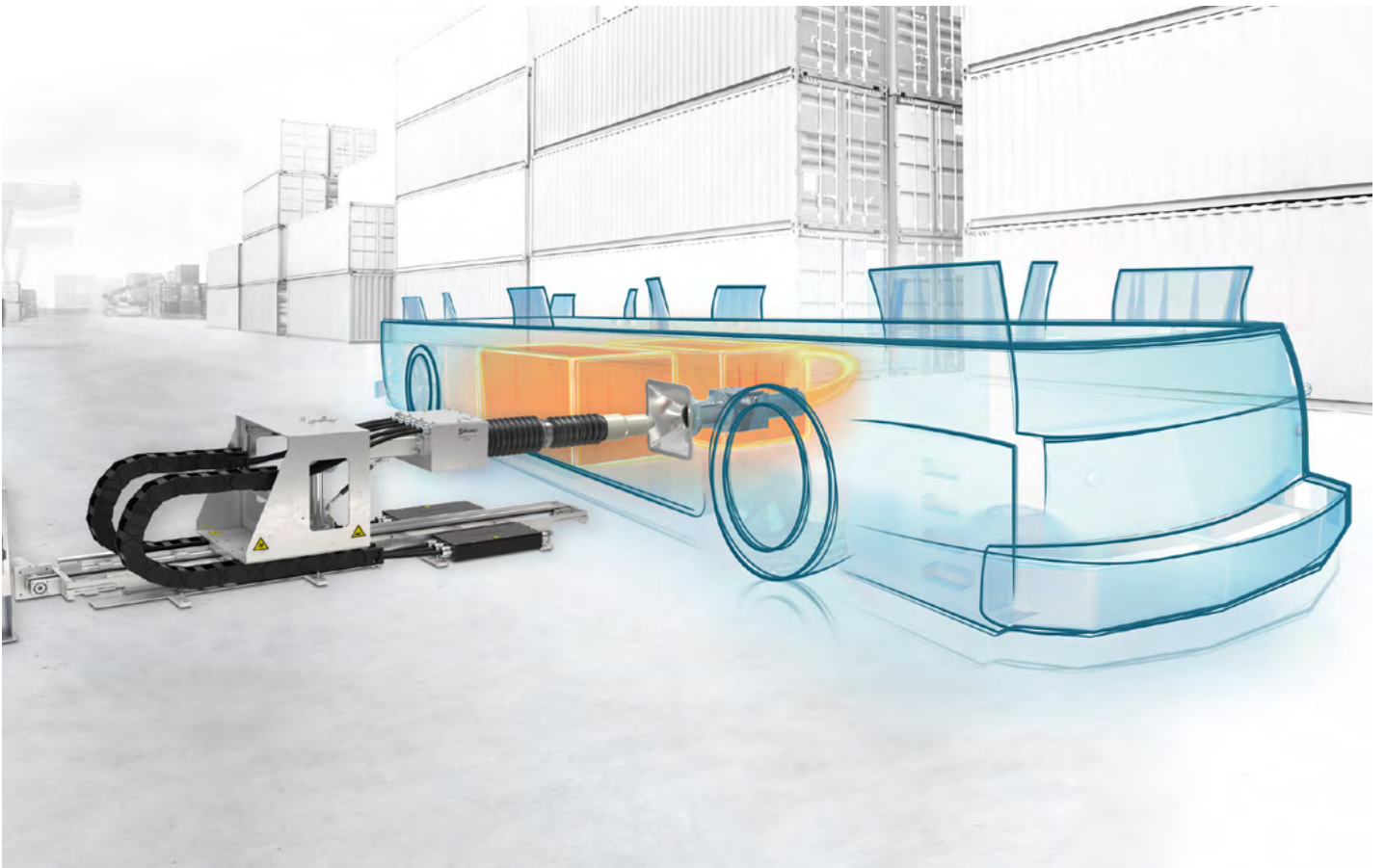



With the innovative QCC for high-performance charging systems, Stäubli offers a universal solution for the automated charging of different types of electric vehicles, such as AGVs, buses, trucks, mobile machinery and even ships.

QCC is designed to meet even the most demanding requirements with high efficiency with low maintenance.

This powerful solution features an automated connection device that enables the transmission of high voltages and thus the rapid recharging of energy storage devices such as lithium-ion batteries and supercapacitors. It can reduce the amount of energy to be stored thanks to the rapid charging process, increasing vehicles' payload for transporting goods.



Cost efficiency



Exceptional safety



**Proven
MULTILAM Technology**



Versatility

CHARGING SOLUTIONS – APPLICATIONS

We keep your operations moving.

At Stäubli, we develop automated charging solutions that help you to maximize the availability of electric-powered vehicles, no matter how harsh or challenging the environment. The QCC rapid charging system is already proving itself in high-performance mobile machinery and ferry operations today. Whenever loading or unloading goods or passengers, QCC is there to transmit the highest power in the shortest possible time.

The fully automated, rapid charging solutions are built to operate under harsh con-

ditions with dirt, dust, humidity and high temperatures. Our solutions for the shipping industry are equally robust: they are resistant to salt water and unaffected by motion caused by waves. With Stäubli QCC, you can always count on perfect functionality and the simplest possible operation.

Automated Guided Vehicles

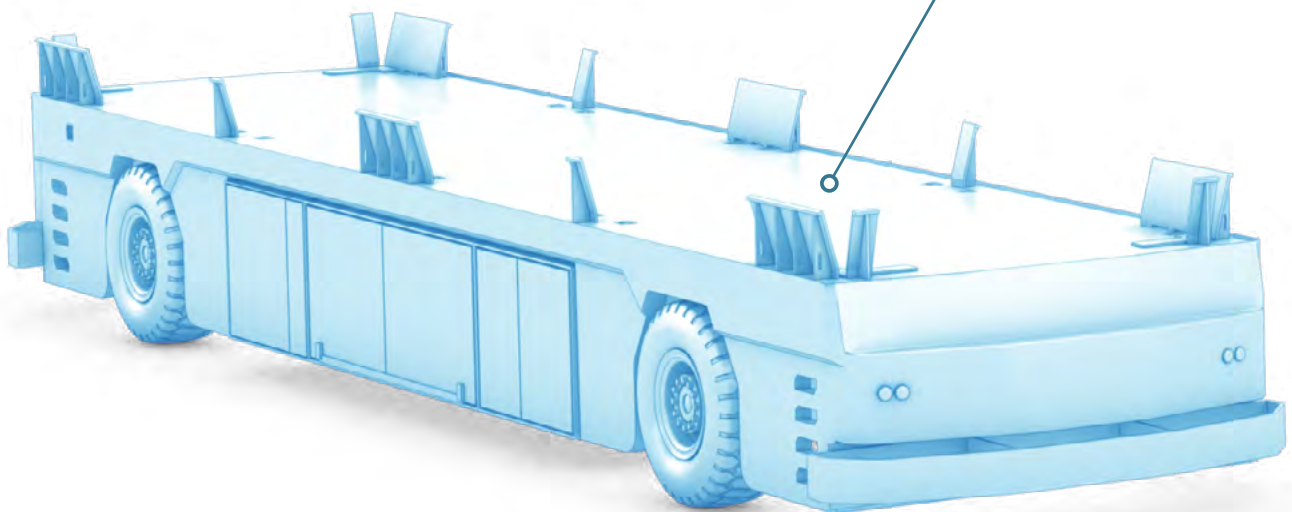

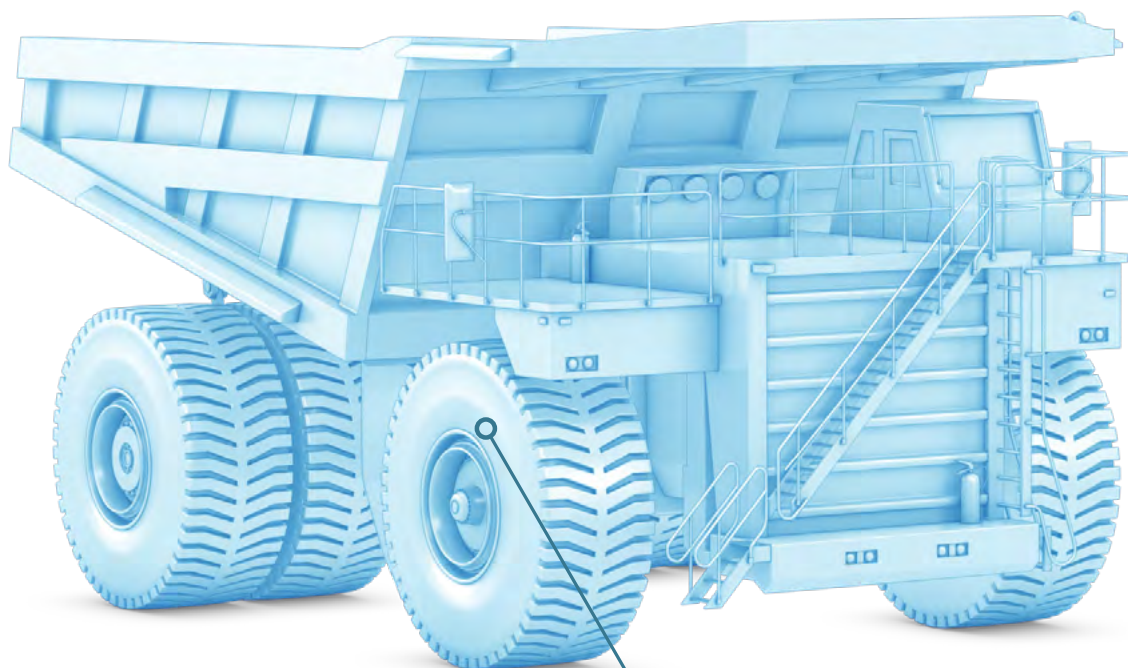

Powerful Utility Vehicles

Ideal for autonomous transport systems.

The future of e-mobility would not be complete without rapid charging systems for automated guided vehicles (AGVs). Their electric powertrains provide exceptional energy efficiency, low maintenance and environmental friendliness. Especially when combined with an intelligent, automated charging solution, AGVs can achieve maximum long-term performance.

Autonomous transport systems are often used in challenging environments like sea-ports. Hence the requirements for charging solutions are very demanding. The fully automated QCC rapid charging system offers exceptional operational flexibility, safety and durability that lasts.

REFERENCE SINGAPORE

Case Study - PSA Singapore.

Automated port operations with quick and reliable connections for AGVs at the world's largest container transshipment hub.



In 2040 when PSA Singapore's Tuas Mega Port is fully operational, it will be the world's largest fully automated container terminal in a single location. In preparation for this new mega port, automated charging systems for a fleet of battery-powered automated guided vehicles (AGVs) with a carrying capacity of 65 tonnes and a cruising speed of 25 km/h were tested and evaluated.

QCC by Stäubli proved to be the fastest and most reliable way to recharge AGV batteries

during operation, in addition to having a long service lifetime and a high number of mating cycles. Moreover, the rapid charging system features a fully enclosed design to protect the contact elements from the harsh sea environment and ensure low maintenance. QCC's waterproof design and high-quality, impermeable materials provide unparalleled safety and reliability.

The automated rapid charging system supplies power to enable AGVs with four to five

hours of continuous operation with less than 20 minutes of charging time. To maximize the availability of the entire AGV fleet, quick battery pack replacements during maintenance have also been made possible by the Stäubli Multi Connect System, which allows for the power supply to be connected and disconnected without any human intervention.



Read more

MINING OUTLOOK

Wielding the power to electrify mining.

Electric mining vehicles play a critical role in the transition to a net-zero economy. Stäubli enables electrified mining operations to maximize uptime with automated charging solutions.

Diesel-powered mining vehicles account for up to 80% of direct carbon emissions at a mine site, especially when long travel and haul times are required. Shifting toward electrification in the mining industry requires fleets of battery electric vehicles (BEVs) to haul several tons of material across rugged and remote terrain multiple times every day.

As electric mining trucks evolve, charging infrastructure is becoming faster and more robust. To maximize performance and ensure continuous mining operations, Stäubli developed QCC – a fully automated, rapid charging system. Moreover, the high-performance charging solution is built to provide outstanding safety and withstand harsh environments, including extreme dust, humidity, and heat.

Unparallel efficiency and safety

Short charging times allow relatively trouble-free operation and high utilization and availability of the mining vehicles. Unlike battery swapping or stationary charging solutions that demand additional labor and vehicle downtime, QCC by Stäubli offers fully automated, high-powered charging stations on-site.

The high-performance charging solution also features self-cleaning technology to help extend the equipment life and maximize return on investment. What's more, all charging contact elements are fully enclosed during all mating stages (unmated, insertion, mated) to reduce maintenance and ensure the safety of workers.

Stäubli's QCC offers scalable charging power and interoperability according to IEC 63407 and SAE3105/3 standards. The solution is easy to integrate and requires no external position sensors or adjustment parts, thanks to its integrated angular design that compensates for positioning misalignments.

Automated, ultra-fast charging is the key to unlocking the future of mining. The QCC rapid charging system can provide up to 1500 V and 670 A continuous or 1500 A short-term. Stäubli engineers constantly upgrade the QCC standard range and aspire to develop high-powered solutions with up to 6MW for even faster charging speeds.

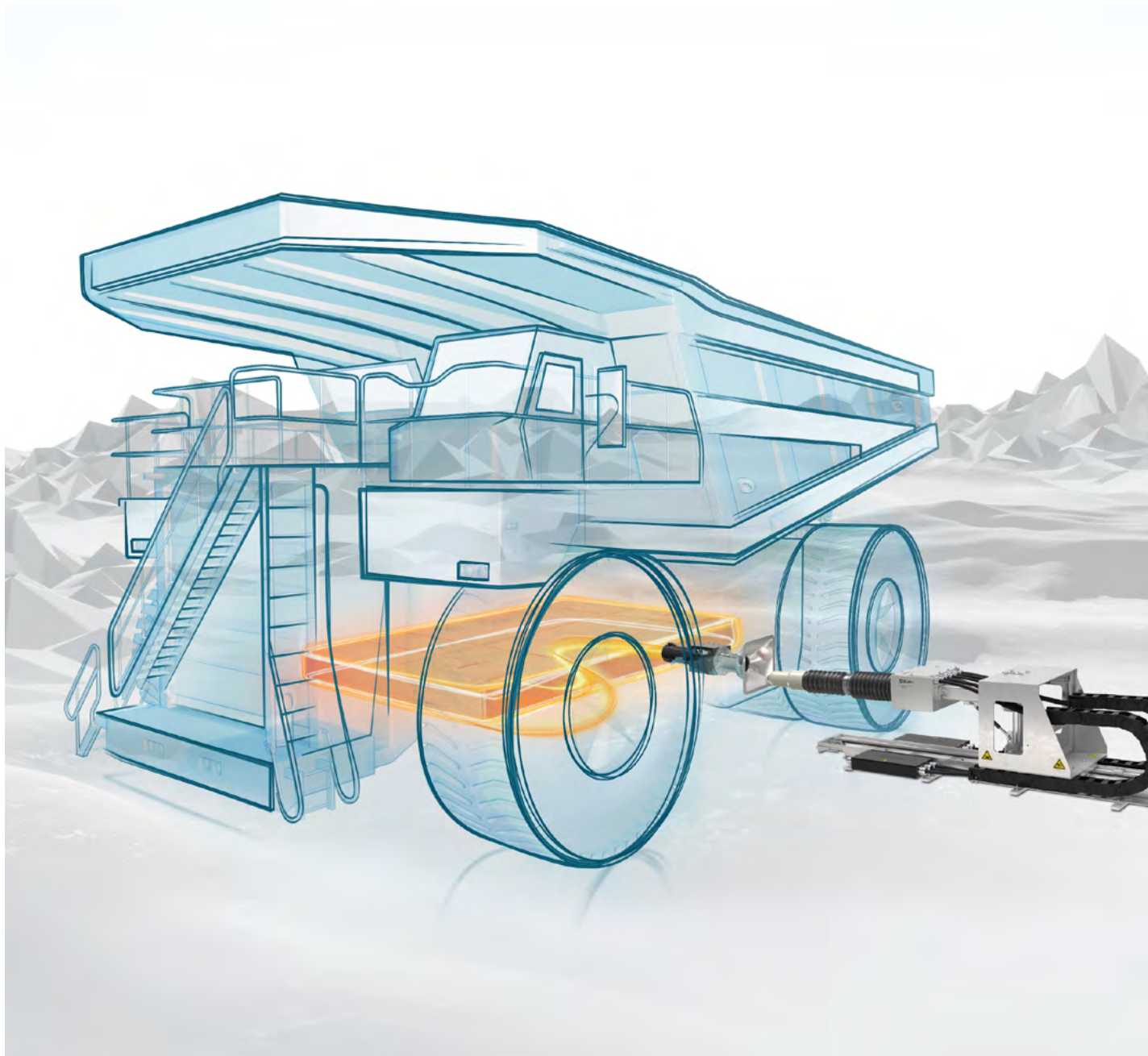

PRODUCT BENEFITS

Safety is our highest standard.

Benefit from the highest levels of contact protection thanks to our standard safe mode feature.

Especially when exposed in outdoor environments, the protection against the ingress of rain and water in the charging system is essential to prevent contact damage or injuries. Stäubli QCC rapid charging solutions are touch-protection (IPX2) and come with our standard safe mode feature, which minimizes the risk of damage.

The safe mode feature ensures that full contact force is only exerted when the automated connection device is fully in the socket.

At all other times, the extension force is reduced to prevent damage or injury. You can always rest assured that anything that accidentally comes between the space between the vehicle and the charging station remains safe.

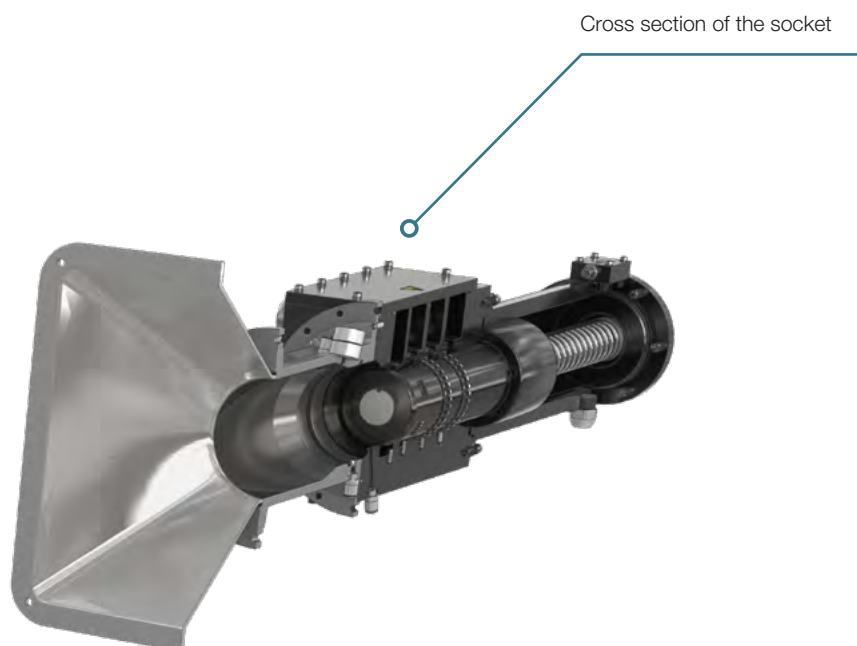

QCC 1500

The QCC system – greater safety comes standard.



Technical data		
Rated voltage	DC 1500 V	
Current* at 15% duty cycles (20-minute intervals)	1440 A	Example: 1.44 MW @ DC 1000 V 2.16 MW @ DC 1500 V
Overvoltage category	CATIII	
Pollution degree rating	3	
Rated current ¹⁾	670 A ¹⁾	Example: 670 kW @ DC 1000 V 1 MW @ DC 1500 V
Lower and upper temperature limits	Ambient temperature range: Below 0 °C: Above 40 °C:	0 °C 40 °C with additional heating system possible with reduced current
Protection type	IP55	
Number of contacts	2 + PE	
Mating cycles	100,000 ²⁾	
Standards	SAE J3105 SAE J3105/3 NRTL (pending approval) IEC 61851-23	

¹⁾ Detailed information on current and duty cycles on request

²⁾ Depending on environment; more cycles possible with maintenance, see MA415.

SERVICES AND SUPPORT

Your success is our greatest reward.

The engineers and experts at Stäubli love a good challenge, especially when it comes to e-mobility and automated rapid charging systems. Together with you, we find innovative, reliable and safe solutions for any environment.

Our primary business philosophy is to always be there for our customers. We apply this approach to everything we do – from customer collaboration to technical support and service. If you're looking for a dependable partner with reliable connections, let us discuss your requirements and explore various solutions to find the ideal automated rapid charging system for your operation.

Stäubli Group is an international company with Swiss roots and over 130 years of experience. We offer our customers worldwide solutions in the Electrical Connectors, Fluid Connectors, Robotics and Textile divisions. Our global workforce is committed to increasing our customer's sustainability and productivity across many industrial sectors.



 Get in touch



● Stäubli Units ○ Representatives/Agents

Global presence of the Stäubli Group

www.staubli.com