

# MPS

Robotic tool changing systems  
for payloads up to 55 kg

**Productivity for all industrial sectors**



# Table of contents

<b>System structure</b>	<b>4</b>	<b>MPS 035/055</b>	
		MPS 035 COMPLETE	28
<b>Tool stand technology</b>	<b>5</b>	MPS 055 COMPLETE	29
		MPS 035/055 MODULAR	30
<b>Quick change technology</b>	<b>6</b>	MPS 035/055 – Tool stand	34
<b>MPS Safety+</b>	<b>8</b>	<b>MPS 015/025/035/055 Transfer modules</b>	<b>38</b>
		FTM transfer modules for pneumatics and vacuum	40
<b>MPS solution competence</b>	<b>10</b>	ROK transfer modules for pneumatics	44
Ideal use of robot performance	10	Ground pin modules for shielding and grounding connection	46
Unique variety of technologies for maximum productivity	11	Transfer modules for tool coding	47
		Electrical modules for data and signal transfer	48
<b>End-of-Arm-Tooling</b>	<b>12</b>	D-SUB transfer modules for signals and data	49
		DuraDock Vision transfer modules for camera applications	50
<b>Selection of system size</b>	<b>14</b>	DuraDock Ultra transfer modules for ultrasonic applications	51
The optimal changing system for every robot	14	DuraDock Giga10 transfer modules for signals and data	52
		Transfer module for RFID	54
<b>Payload overview</b>	<b>16</b>	Tool hanger module	55
		Safety+ modules	56
		Safety+ valve unit	58
<b>MPS 015/025</b>		<b>MPS 015/025/035/055 Accessories</b>	<b>60</b>
MPS 015 COMPLETE	18		
MPS 025 COMPLETE	19	<b>MPS CUSTOMIZED</b>	<b>62</b>
MPS 015/025 MODULAR	20		
MPS 015/025 – Tool stand	24		

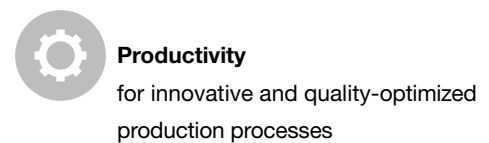
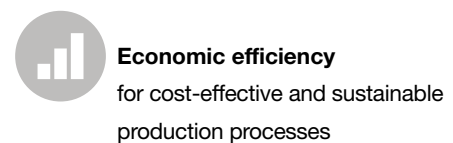
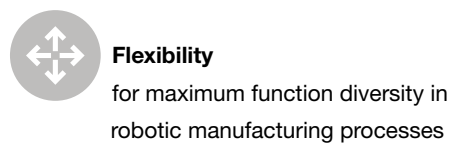
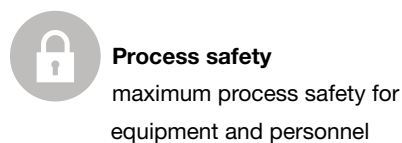

THREE SOLUTIONS

# Our systems are just as flexible as your processes

Stäubli robotic tool changing systems are designed according to a modular product concept that guarantees variable multifunctionality and optimum integration into all industrial robot manufacturing processes.

Based on the payload-dependent base units on the robot and tool side, Stäubli offers you three efficient solutions for the ideal tool changing system.



## MPS COMPLETE

Ready-to-use application solutions

- robot tool changer modules suitable for the most common manufacturing processes worldwide
- shortest delivery times for complete systems
- can be supplemented with further transfer modules at any time
- simple and easy connection of the robot cable package
- future repositioning of the transfer modules to adapt to requirements

## MPS MODULAR

Individually configurable solutions

- full choice of transfer modules
- delivered as a fully assembled robotic tool changer
- simple configuration system for the entire ordering process
- shortest delivery times for single components
- flexible positioning of the transfer modules for easy connection of the cable package
- future repositioning of the transfer modules to adapt to requirements

## MPS CUSTOMIZED

Customized designs

- individual design of all performance data, material qualities and connection options
- all individual components are adapted to the specific application
- individual tool stands enable optimal system integration
- flexible positioning of the transfer modules for easy connection of the cable package
- future repositioning of the transfer modules to adapt to requirements

## SYSTEM STRUCTURE

# Simple integration thanks to open product system

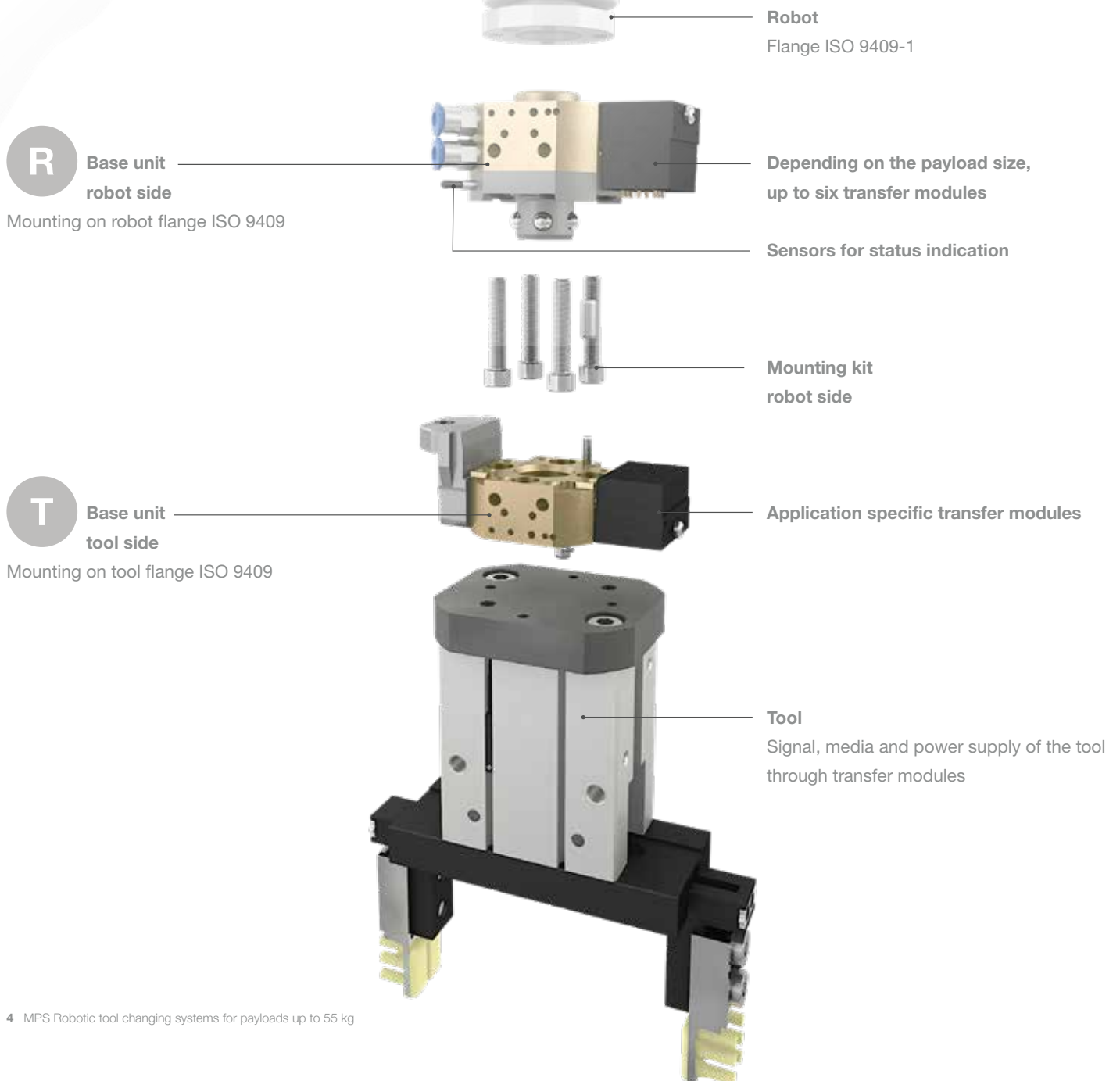

TOOL STAND TECHNOLOGY

# Optimal system integration for maximum efficiency

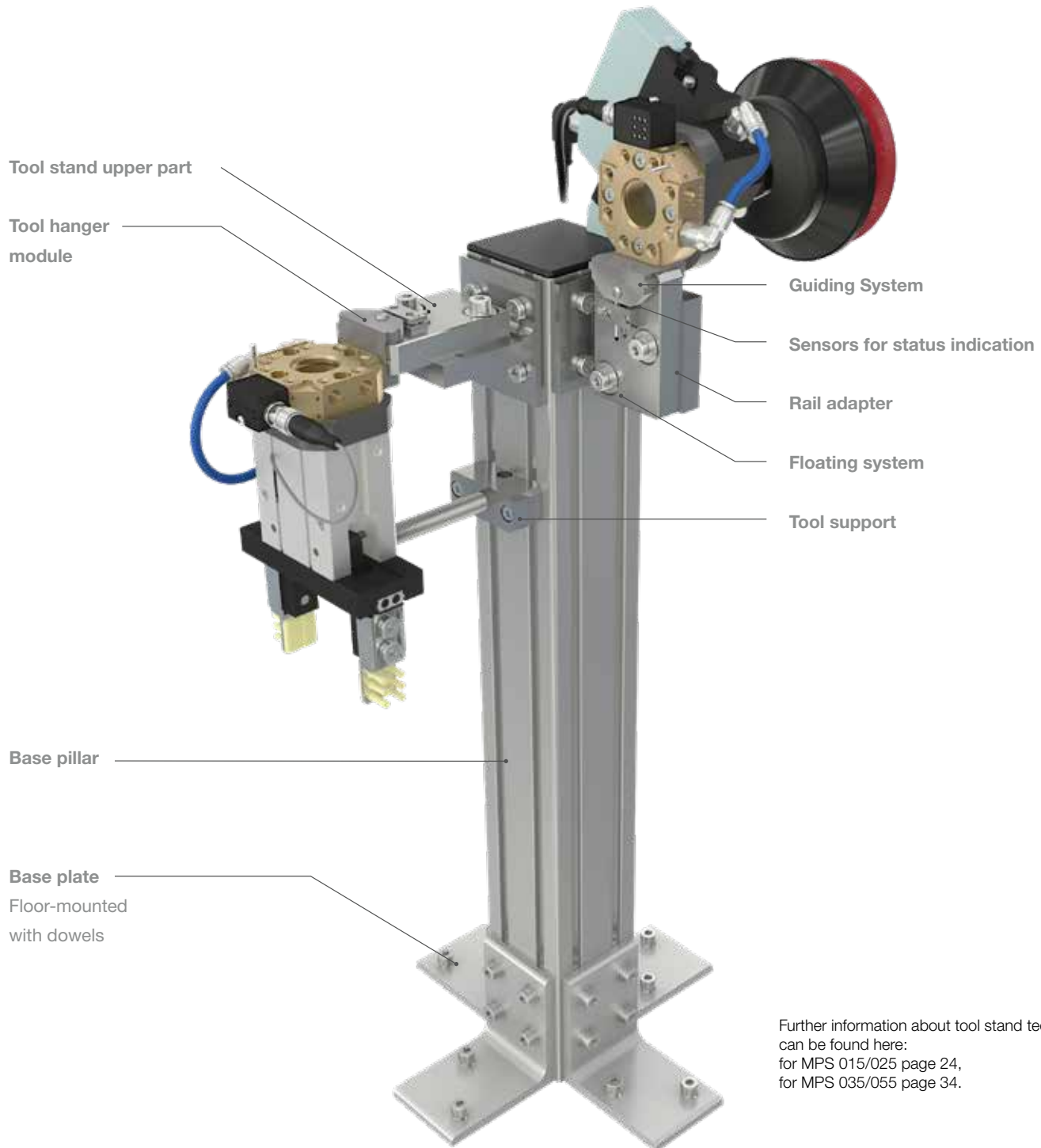

Further information about tool stand technology can be found here:  
for MPS 015/025 page 24,  
for MPS 035/055 page 34.

## QUICK CHANGE TECHNOLOGY

# MPS product system for Payload up to 55 kg

R

Base unit  
robot side

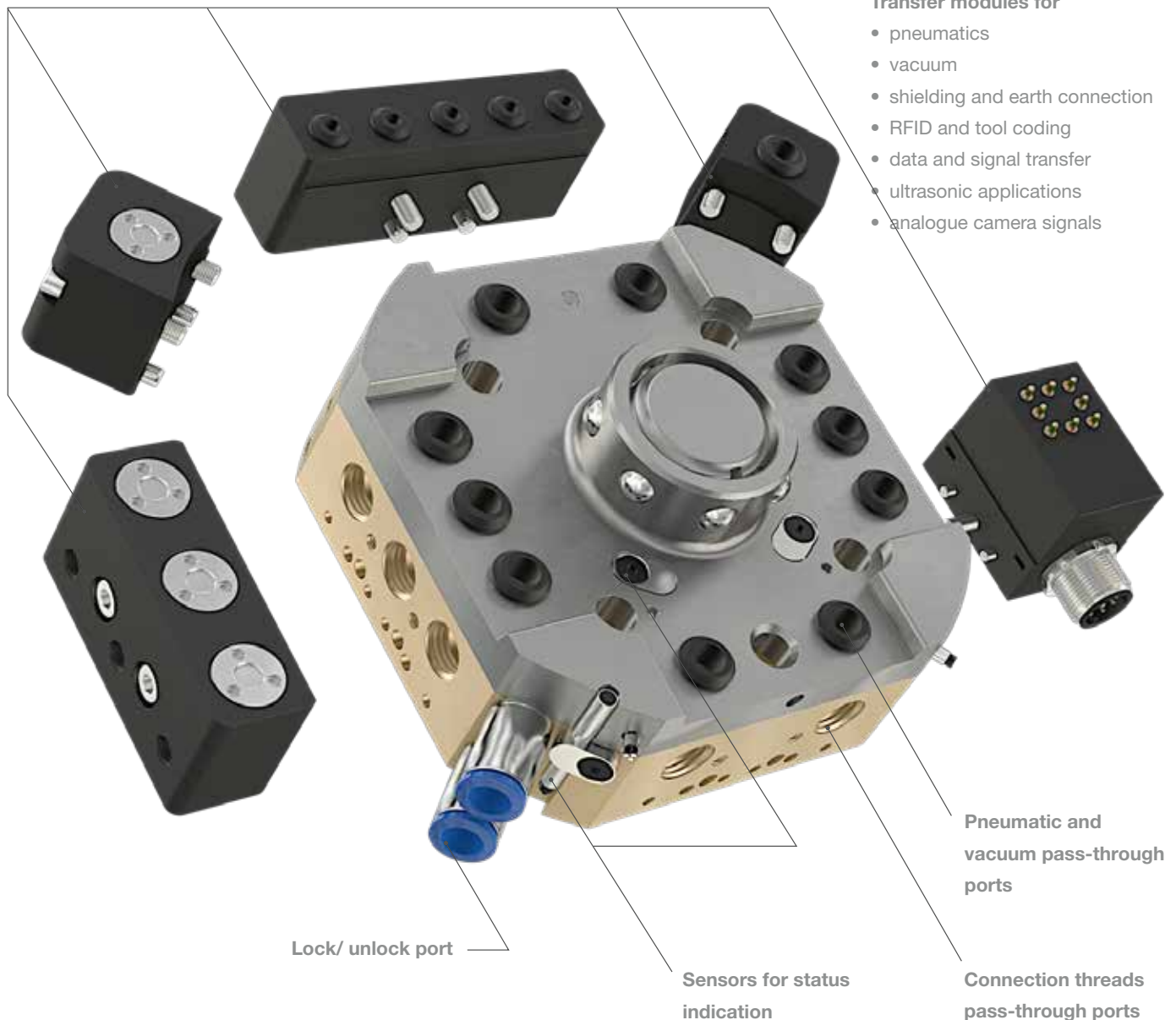



**Base unit  
tool side**

**Transfer modules for**

- pneumatics
- vacuum
- shielding and earth connection
- RFID and tool coding
- data and signal transfer
- ultrasonic applications
- analogue camera signals

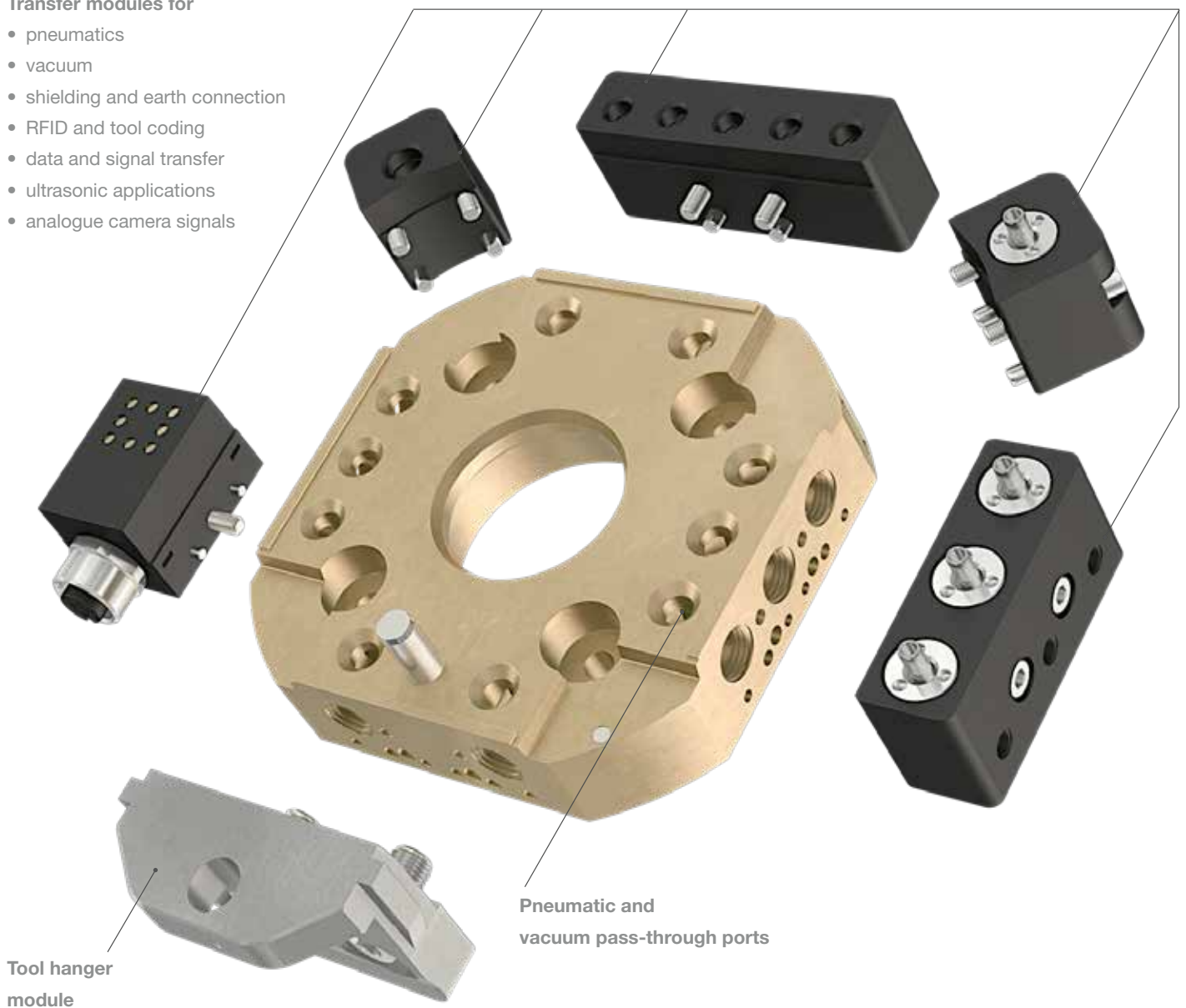

**MPS SAFETY+**

# System for personal and system safety

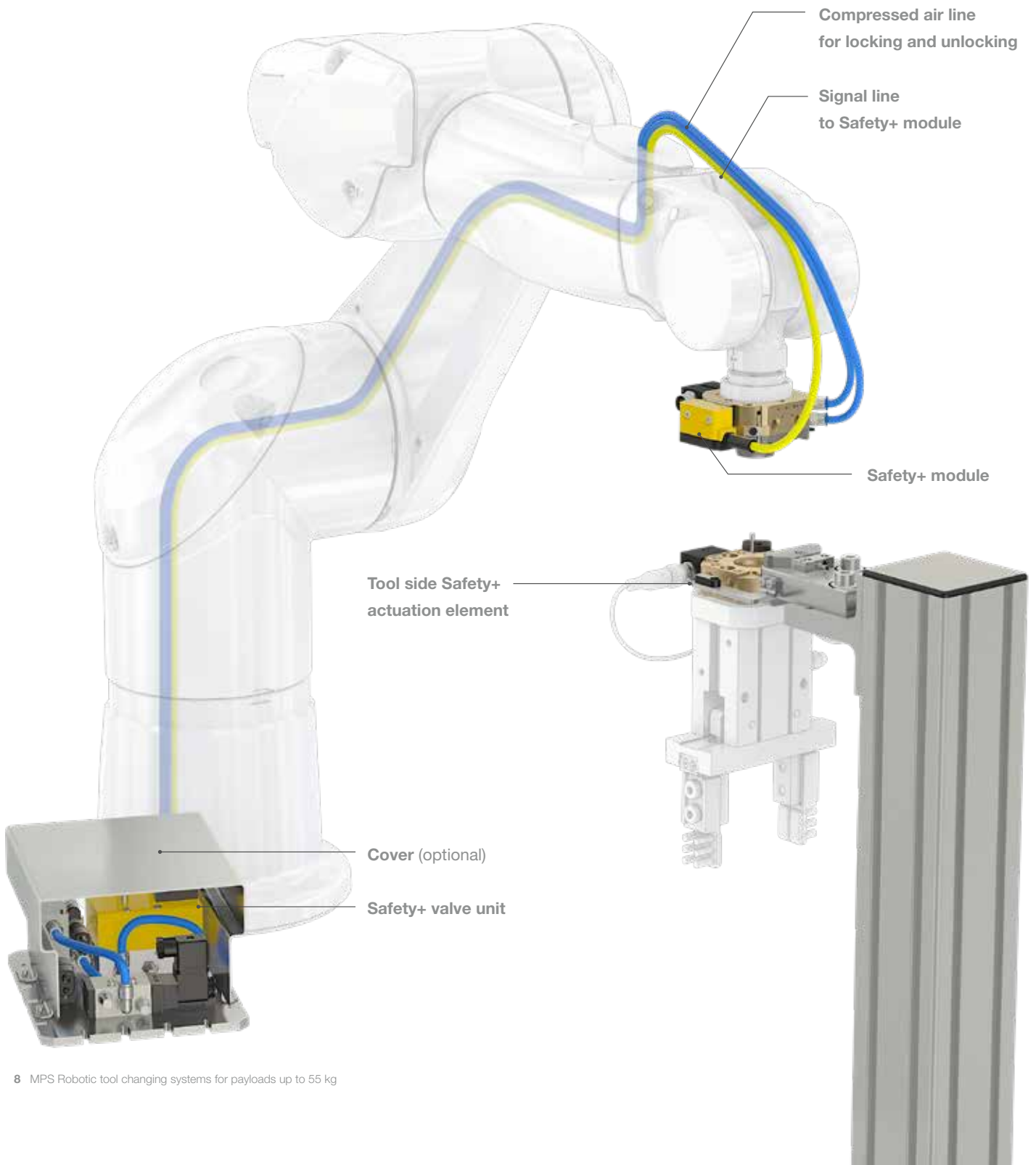





**Robot side  
Safety+ module**



**Tool side  
Safety+ actuation element**

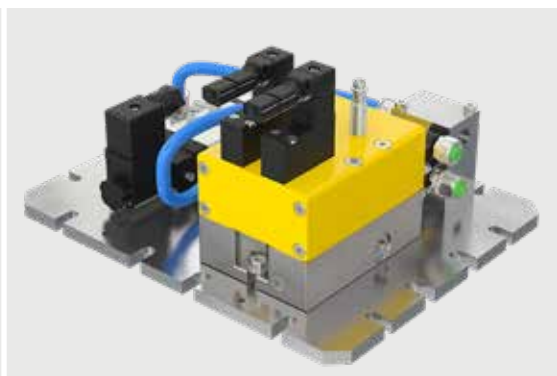

**Safety+ valve unit**

**Safety of people and equipment always takes top priority. Over the entire life cycle of this changing system, each individual tool change must meet this requirement.**

According to standard ISO 10218-2, it must be ensured that energy loss or misuse does not lead to a hazard. Safety equipment, such as safety fences, are not always adequate for this.

**MPS Safety+ system for  
Performance Level d, Category 3**

Everyday maintenance or teaching situations with the protected area open require a safety function that prevents decoupling

the tool outside the provided docking positions. This applies wherever people and robots collaborate.

The MPS Safety+ system from Stäubli offers exactly this safety.

**Operating principle**

The Safety+ module on the robot side is equipped with a transponder-coded safety switch. The counterpart is the Safety+ actuator mounted on the tool stand. Only when the Safety+ module is positioned in the safe detection area of the actuator does the valve unit placed on the robot release the compressed air feed to unlock the MPS. Only then can the tool changing sys-

tem be locked and unlocked. The valve unit for the compressed air feed must be monitored by the customer's docking or robot controls. This is how the Stäubli Safety+ system ensures the high safety level called for by Performance Level d, Category 3.



**Advantages**

- Personal and system safety
- Can be retrofitted to existing systems
- Coordinated system solution
- Maintenance-free components
- Enables Performance Level d, Category 3

# Ideal use of robot performance

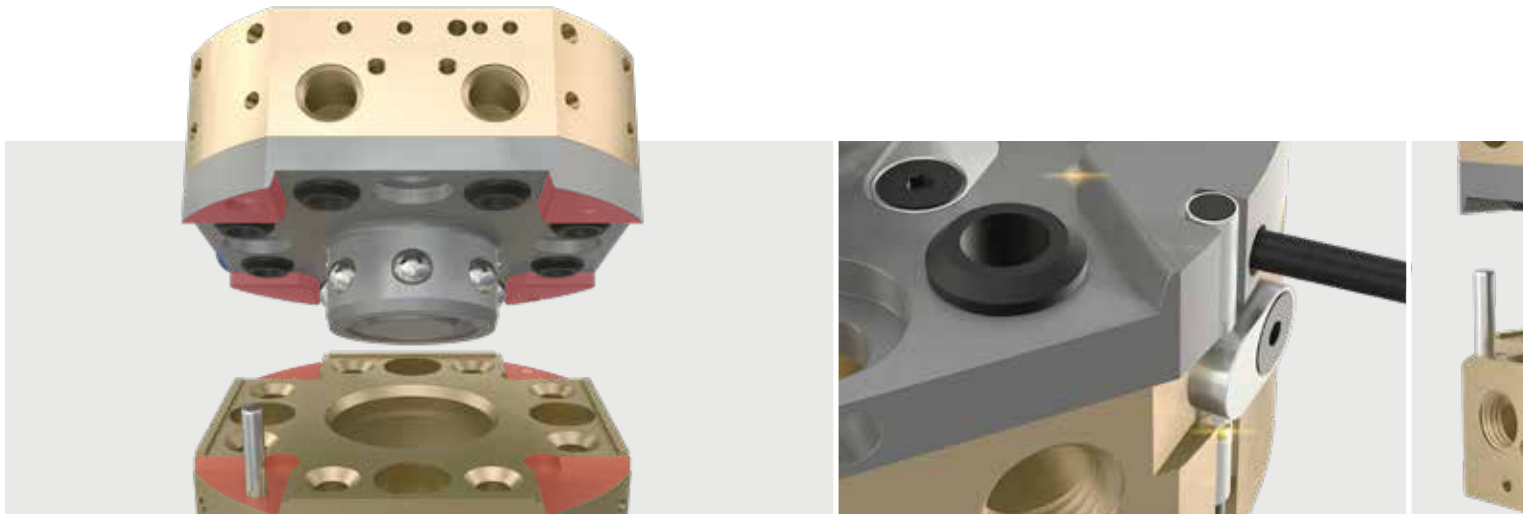

The powerful locking system in combination with the crosswise acting guiding surfaces ensures accurate positioning and repeatability.

Optional proximity switches for status requests that can be integrated directly to save space

**Stäubli's know-how of robotic tool changing systems is comprehensive in every respect and draws on, among other things, its decades of experience as a robot and coupling manufacturer. In-depth, technical developer knowledge and expertise in the industrial requirements for robot production lines lead to variable changer solutions designed for all existing robots on the market.**

No matter what type of robot, manufacturer or year of construction, MPS systems from Stäubli can be installed on any robotic arm produced anywhere in the world. The changer mounting flanges can be mount-

ed directly on ISO 9409 robot flanges and relay this drilling pattern for the assembly of the tool. The optionally available status request can be directly integrated into the changer system to save space.

The overall height of the coupled changer system therefore remains limited to a minimum. This has a positive effect on the tool's moment of inertia and enables the optimum use of the robot payload.



## Productivity

Stäubli's robotic tool changing systems ensure a friction-locked and high precision connection between robot and

tool side. Their intelligent construction ensures absolute precision and a long service life of the tool changing system as well as safe and error-free processes.



## Process safety

The positioning system guarantees precise repeatability of the change process ( $\pm 0.0015$  mm in all directions). The cross-shaped positioning surfaces ensure that even following a high number of change cycles, the tools are always brought into their 100 percent exact operating position.

# Unique variety of technologies for maximum productivity

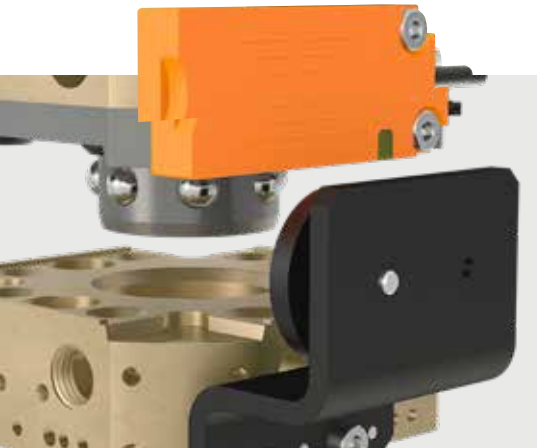

**RFID module for tool coding or also data storage**

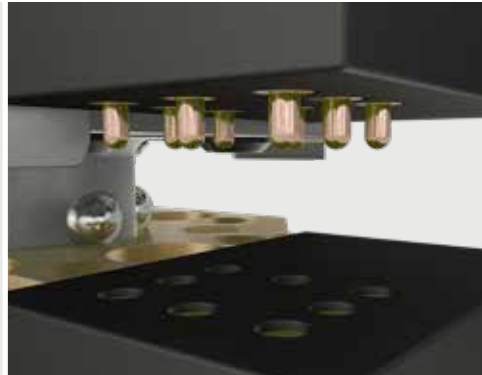

**Compact electrical modules for flexible data and signal transfer**



**ROK pneumatic module, shut-off**

The modular design of the MPS series provides the ideal platform for a flexible and versatile system. For all robotic applications there are suitable transfer modules available, which can be simply integrated into the tool changer systems.

Even without transfer modules, the changer's base units are already equipped with integrated feedthrough for pneumatics or vacuum.

In addition to the tool hanger module for each size, there are numerous modules to choose from (overview on page 38).



### Economic efficiency

MPS tool changers are only fitted with the modules required for your applications on the robot side. On the tool side, you only need the transfer modules that are required for the operation of the respective tool. Your investment is therefore reduced to a minimum.



### Flexibility

The modular design allows you to adapt the system at any time. In this way you can flexibly design changes to your robot manufacturing processes and are not subject to any restrictions.

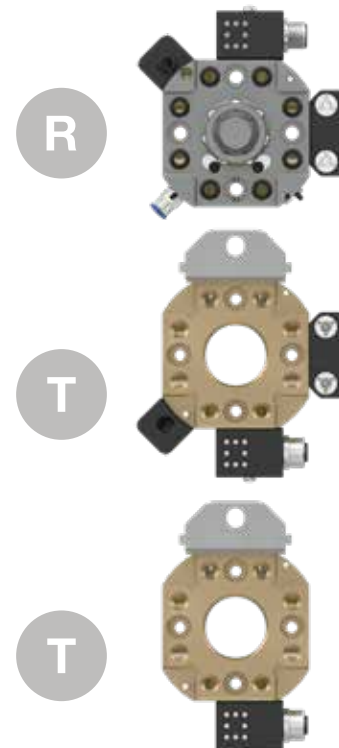

## END-OF-ARM-TOOLING

# End-of-Arm-Tooling solutions for all robot applications



**Stäubli offers comprehensive and highly flexible End-of-Arm-Tooling solutions for robotic handling in all automated manufacturing processes. Our extensive portfolio makes technologies such as gripping, suction and cutting for all robots worldwide available from a single source - including manual or automatic robotic tool changing systems.**

### **Broad technology portfolio for robotic handling from a single source**

The combination of mechanical and vacuum gripping, often together with tool changing systems, is an everyday requirement in robotic handling. Stäubli offers you the entire End-of-Arm-Tooling spectrum required, from a single source and for all robots worldwide.

This wide range of products means that you can source all of the necessary components for your End-of-Arm-Tooling from a single specialist. You not only reduce supplier interaction but also minimize the risks of mismatched components from many different sources.

### **Flexible and durable systems for sustainable productivity**

The durability and flexibility of the solution are critical to the long-term return on investment of your End-of-Arm-Tooling.

Stäubli provides high-precision and high-quality products with a long service life. The flexibility of our solutions ensures the long-term usability of your investment over this long period – even if your processes and requirements change.

Stäubli is your expert for sustainable productivity in End-of-Arm-Tooling.





**Always a tailored solution for your requirements**

Need an experienced partner to define the concept of your End-of-Arm-Tooling? Does your process require a unique solution that is designed around your robot applications? Need advice on the use of individual End-of-Arm-Tooling components?

Our experienced project planning team will be happy to support you at any time in the development of the perfect solution for your requirements. We undertake the complete definition and CAD planning of the entire system for you, based on your general conditions and application requirements.

Depending on your requirements, we can

supply all the necessary components for self-assembly. Or you can choose our complete solution, which we deliver to you fully assembled. Let us find your solution.



**Advantages**

- Always a tailored solution for your requirements
- Broad technology portfolio for robotic handling from a single source
- Flexible and durable systems for lasting productivity
- The highest quality of advice and service, local to you, throughout the world

The comprehensive expertise of our strategic cooperation partner FIPA is reflected in this Stäubli offer. FIPA is an internationally active company specialising in the development and manufacture of quality products and innovative system solutions for handling processes.



## SELECTION OF SYSTEM SIZE

# The optimal changing system for every robot

Our MPS COMPLETE and MPS MODULAR solutions offer an almost infinite variety of possible technology combinations. This can be used to provide the ideal configuration for every application and every requirement in all automated or robotic manufacturing processes.

If you have any further specific requirements, our MPS CUSTOMIZED solution or another MPS payload size is the right choice. Further information can be found on page 62.

The four MPS COMPLETE and MPS MODULAR system sizes in the payload range up to 55 kg are precisely matched to the relevant robot parameters:

### MPS 015

PCD Ø 31.5 mm  
Payload 10 kg

COMPLETE page 18  
MODULAR page 22

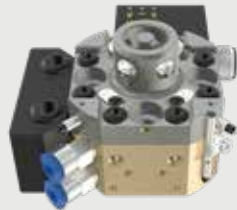

### MPS 025

PCD Ø 40 mm  
Payload 20 kg

COMPLETE page 19  
MODULAR page 23

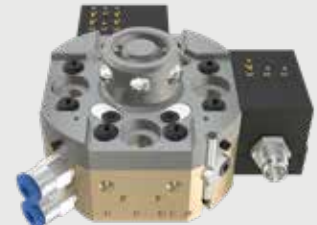

### MPS 035

PCD Ø 50 mm  
Payload 35 kg

COMPLETE page 28  
MODULAR page 32



### MPS 055

PCD Ø 63 mm  
Payload 55 kg

COMPLETE page 29  
MODULAR page 33

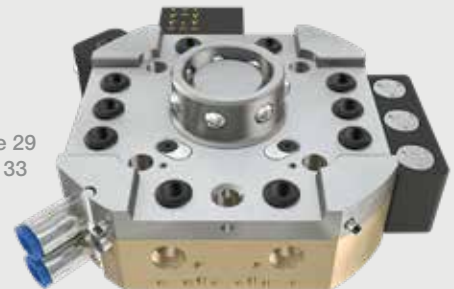

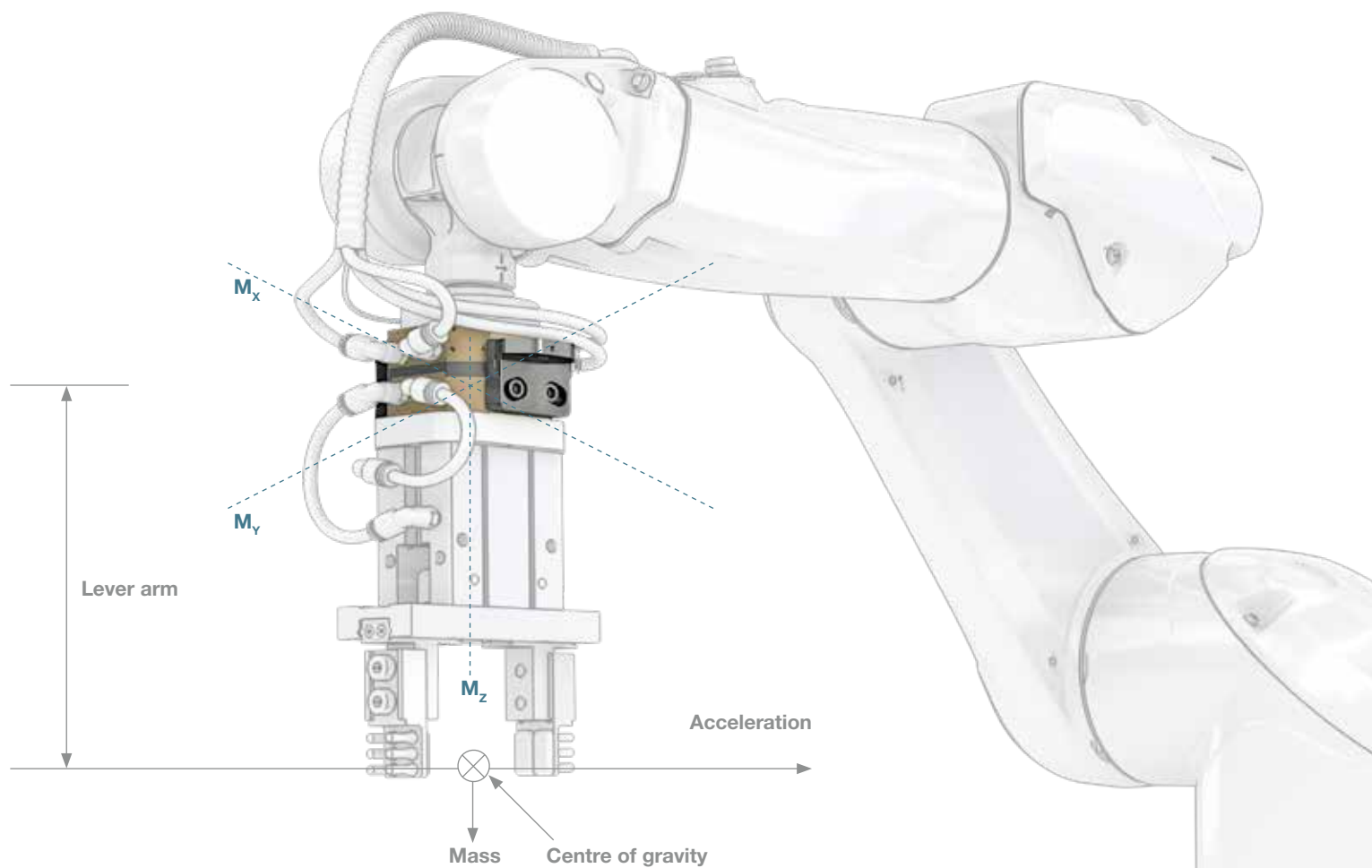

There are two options for selecting a suitable MPS:

**Option 1 – MPS selection according to robot load data:** The permissible torques of the tool changer system exceeds the torque of the robot.

**Option 2 – MPS selection according to the reference diameter and/or payload:** The application must be calculated using the formula  $Torque = Mass \times Lever\ arm \times Acceleration$ . The max. torques of the tool changer system must not be exceeded under any circumstance. If the max. torque of the MPS needs to be exceeded, the Mass, Lever arm or Acceleration parameter must be adjusted.



Provide us with the robots make, model and year of manufacture and we will be happy to advise you on individual payload determination! Contact us at:



[www.staubli.com](http://www.staubli.com)

## PAYLOAD OVERVIEW

# The right solution for every payload

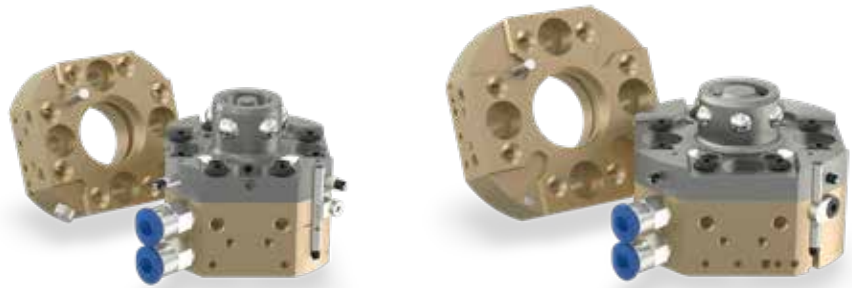

	MPS 015		MPS 025	
	$M_x / M_y$	$M_z$	$M_x / M_y$	$M_z$
max. static moment*	15 Nm	15 Nm	34 Nm	34 Nm
max. dynamic moment*	52 Nm	52 Nm	119 Nm	119 Nm
max. payload	10 kg		20 kg	
max. repulsion force	4 kN		6 kN	
max. connection force	4 kN		6 kN	
max. lateral force	2 kN		3 kN	
Pitch circle diameter (PCD) robot adapter flange	ISO 9409-1-31.5-4-M5		ISO 9409-1-40-4-M6	
Height (coupled)	46 mm		46 mm	
Weight - robot side	0.26 kg		0.4 kg	
Weight - tool side (included adapter)	0.14 kg		0.18 kg	
Compressed air connection	Push-lock hose-Ø 4 mm		Push-lock hose-Ø 4 mm	
Operating pressure	0.45 - 1.0 MPa 0.03 NI/ cycle at 0.6 MPa		0.45 - 1.0 MPa 0.04 NI/ cycle at 0.6 MPa	
Operating temperature	0 °C - +50 °C		0 °C - +50 °C	
Integrated pass-through ports	8 x M5		8 x M5	
Repeatability	+/- 0.0015 mm		+/- 0.0015 mm	
Query	locked/ unlocked/ coupled		locked/ unlocked/ coupled	
Emergency release	yes		yes	
Safety in case of drive medium failure	yes, by compression spring		yes, by compression spring	
Number of module positions	4		4	

\* Due to their potentially high acceleration, robots can generate dynamic moments that are several times higher than static moments. The dynamic moments can occur in an emergency stop situation of the robot. Since they occur only very rarely during the robot's lifetime a static proof of strength is usually sufficient for this purpose.



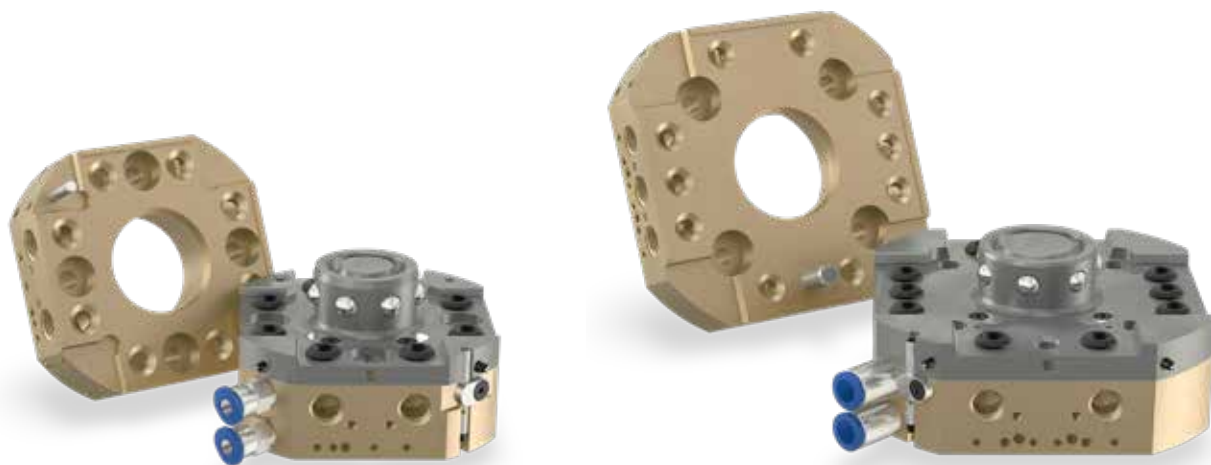

	MPS 035		MPS 055	
	$M_x / M_y$	$M_z$	$M_x / M_y$	$M_z$
max. static moment*	80 Nm	80 Nm	145 Nm	106 Nm
max. dynamic moment*	280 Nm	280 Nm	507 Nm	371 Nm
max. payload	35 kg		55 kg	
max. repulsion force	10 kN		12 kN	
max. connection force	10 kN		12 kN	
max. lateral force	5 kN		6.5 kN	
Pitch circle diameter (PCD) robot adapter flange	ISO 9409-1-50-4-M6		ISO 9409-1-63-4-M6	
Height (coupled)	46 mm		46 mm	
Weight - robot side	0.5 kg		0.89 kg	
Weight - tool side (included adapter)	0.28 kg		0.38 kg	
Compressed air connection	Push-lock hose-Ø 4 mm		Push-lock hose-Ø 6 mm	
Operating pressure	0.45 - 1.0 MPa 0.11 NI/ cycle at 0.6 MPa		0.45 - 1.0 MPa 0.17 NI/ cycle at 0.6 MPa	
Operating temperature	0 °C - +50 °C		0 °C - +50 °C	
Integrated pass-through ports	8 x G 1/8 or NPT or Rc		10 x G 1/8 or NPT or Rc	
Repeatability	+/- 0.0015 mm		+/- 0.0015 mm	
Query	locked/ unlocked/ coupled		locked/ unlocked/ coupled	
Emergency release	yes		yes	
Safety in case of drive medium failure	yes, by compression spring		yes, by compression spring	
Number of module positions	6		6	

\* Due to their potentially high acceleration, robots can generate dynamic moments that are several times higher than static moments. The dynamic moments can occur in an emergency stop situation of the robot. Since they occur only very rarely during the robot's lifetime a static proof of strength is usually sufficient for this purpose.

## MPS 015 COMPLETE

# MPS 015/1

For handling and gripping applications

R

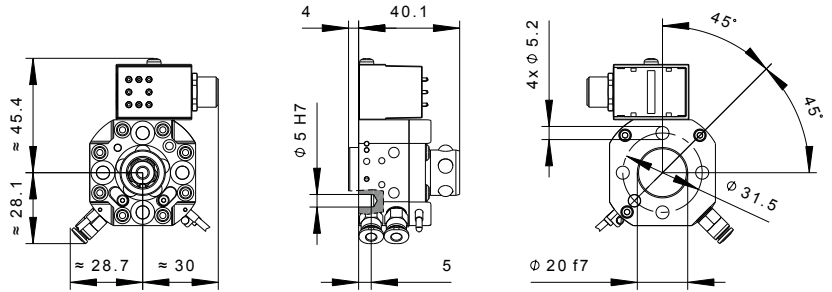

T

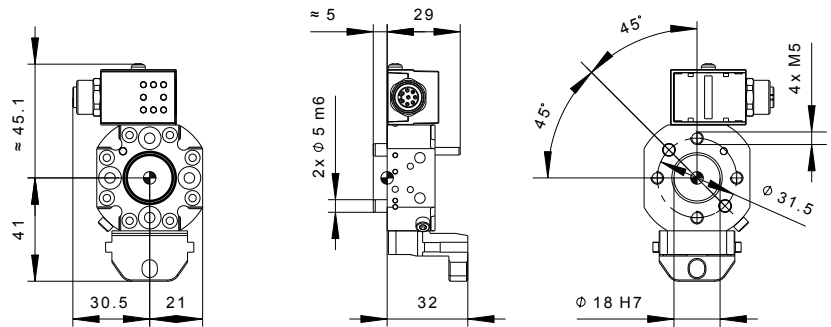

	Order no.	Unlock/ lock port	Pneumatic pass-through		Data and signal transfer		Sensors/ connection
			Quantity	Size	Connection	Pole	
R	MPS015RO-0000-6A8C-0000-D1S0	2x Push-lock hose-Ø 4 mm	4	M5	M12	8	-
	MPS015RC-0000-6A8C-0000-D1S0						3x PNP/ 3x M8
	MPS015RG-0000-6A8C-0000-D1S0						3x NPN/ 3x M8
T	MPS015TO-0000-6A8C-0000-D1S0	-	4	M5	M12	8	-

Technical data for the base unit on the robot and tool sides can be found on page 22.

Technical data for all transfer modules can be found from page 38 onwards.

Transfer modules with other threaded and plug-in connections can be individually adapted at any time via our simple configuration system (see page 20) to suit your individual requirements.

MPS 025 COMPLETE

# MPS 025/1

For handling and gripping applications

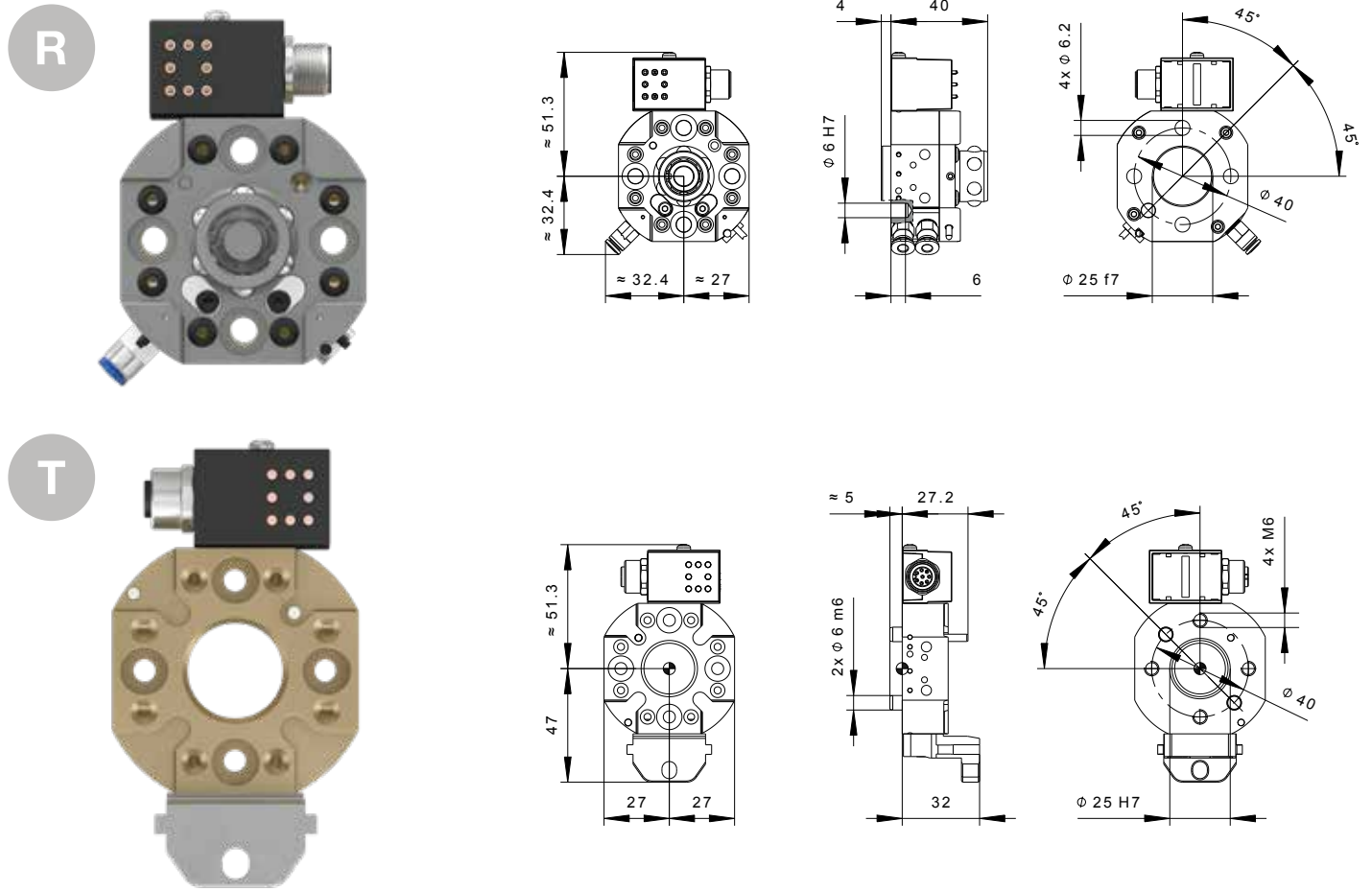

	Order no.	Unlock/ lock port	Pneumatic pass-through		Data and signal transfer		Sensors/ connection
			Quantity	Size	Connection	Pole	
R	MPS025RO-0000-6A8C-0000-D1S0	2x Push-lock hose-∅ 4 mm	4	M5	M12	8	-
	MPS025RC-0000-6A8C-0000-D1S0						3x PNP/ 3x M8
	MPS025RG-0000-6A8C-0000-D1S0						3x NPN/ 3x M8
T	MPS025TO-0000-6A8C-0000-D1S0	-	4	M5	M12	8	-

Technical data for the base unit on the robot and tool sides can be found on page 23.

Technical data for all transfer modules can be found from page 38 onwards.

Transfer modules with other threaded and plug-in connections can be individually adapted at any time via our simple configuration system (see page 20) to suit your individual requirements.





## MPS 015 MODULAR

# MPS 015 base unit robot and tool side

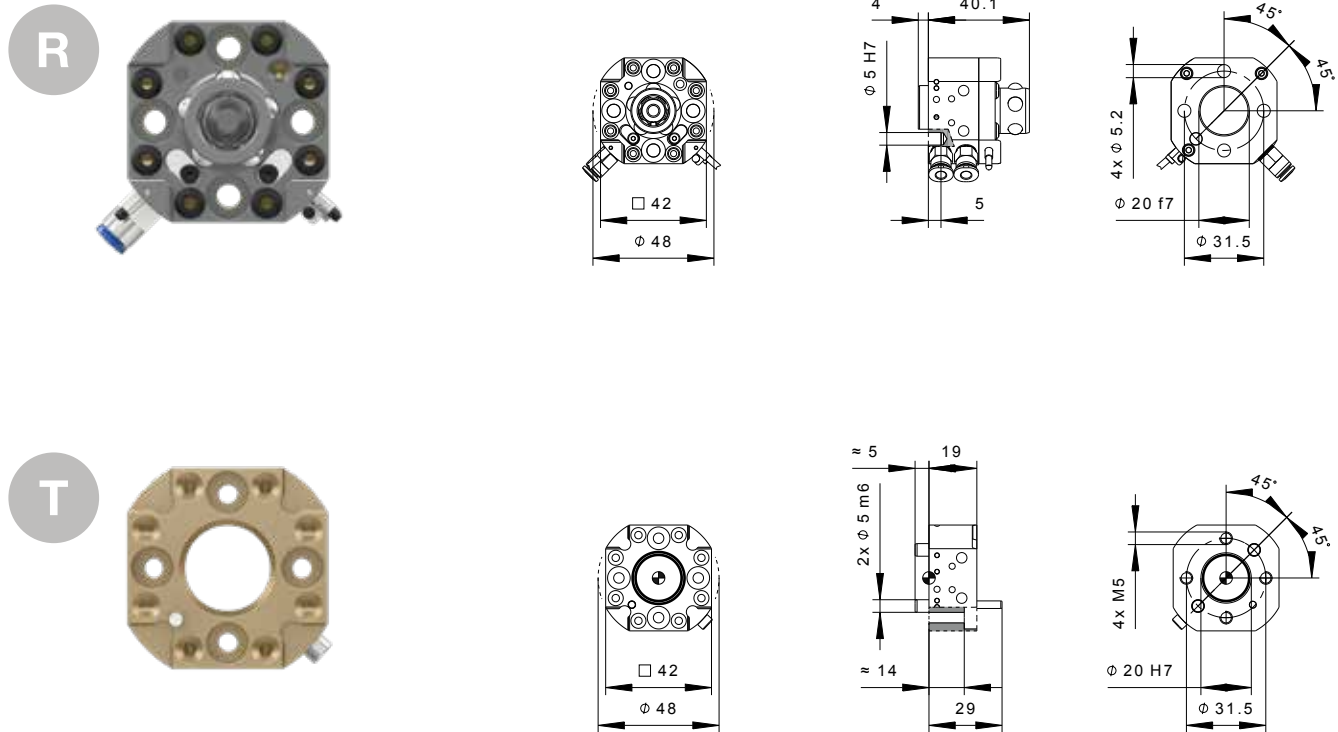

	Order no.	Pitch circle diameter (PCD)	Bending moment	Torsional moment	Operating pressure	Unlock/lock port	Pneumatic pass-through		Sensors/Connection	Module order code
							Quantity	Size		
R	K81557761	Ø 31,5 mm	15 Nm	15 Nm	0.45-1.0 MPa	2x Push-lock hose-Ø 4 mm	8	M5	-	MPS015RO
	K81557762								3x PNP/ 3x M8	MPS015RC
	K81557763								3x NPN/ 3x M8	MPS015RG
T	K81557938	Ø 31,5 mm	15 Nm	15 Nm	-	-	8	M5	-	MPS015TO

MPS 025 MODULAR

# MPS 025 base unit robot and tool side

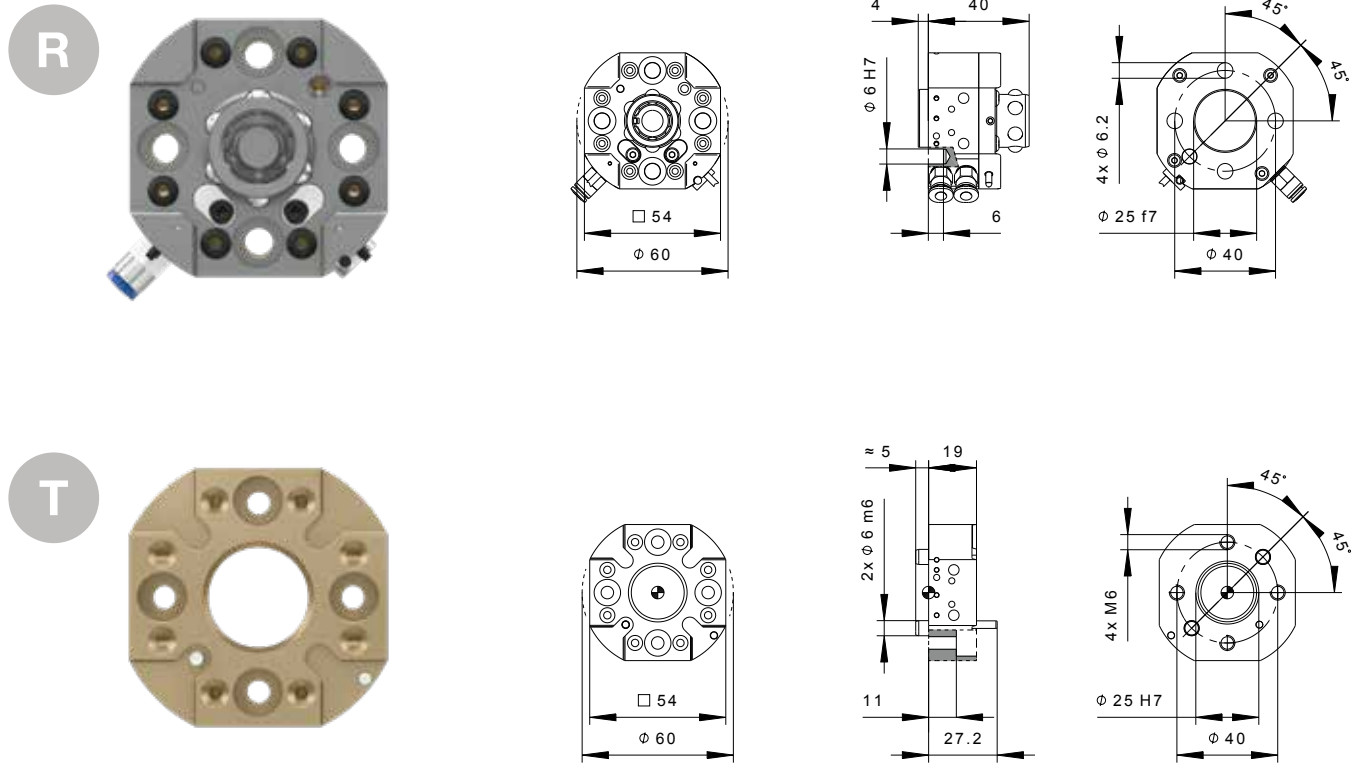

	Order no.	Pitch circle diameter (PCD)	Bending moment	Torsional moment	Operating pressure	Unlock/lock port	Pneumatic pass-through		Sensors/connection	Module order code
							Quantity	Size		
R	K81557764	Ø 40 mm	34 Nm	34 Nm	0.45-1.0 MPa	2x Push-lock hose-Ø 4 mm	8	M5	-	MPS025RO
	K81557765								3x PNP/ 3x M8	MPS025RC
	K81557766								3x NPN/ 3x M8	MPS025RG
T	K81557939	Ø 40 mm	34 Nm	34 Nm	-	-	8	M5	-	MPS025TO

## MPS 015/025 TOOL STAND

# MPS 015/025 – Tool stand

Flexibility and efficiency through integrated tool storage system

**Stäubli consistently applies the modularity of the MPS series to storage systems. Due to the individual components used in the design, there is great scope for flexible process adaptation.**

- **Flexibility:** With the single system components, your own individual storage solutions can be compiled and easily integrated into existing systems.
- **Modularity:** Choose between preconfigured complete systems or single modules that can be used directly with standard profile solutions.
- **Longevity:** The floating bearing in the upper part of the system ensures that the tool is optimally held in the drop-off position. The load on the components is minimized.
- **Economical:** One tool storage system that can be used as a vertical or 90° rotated solution offers a wide range of possible uses.
- **Process reliability:** A mechanical fixation with adjustable retention force enables additional securing of the dropped -off tools. The system can optionally be expanded with integrated sensors for status indication.

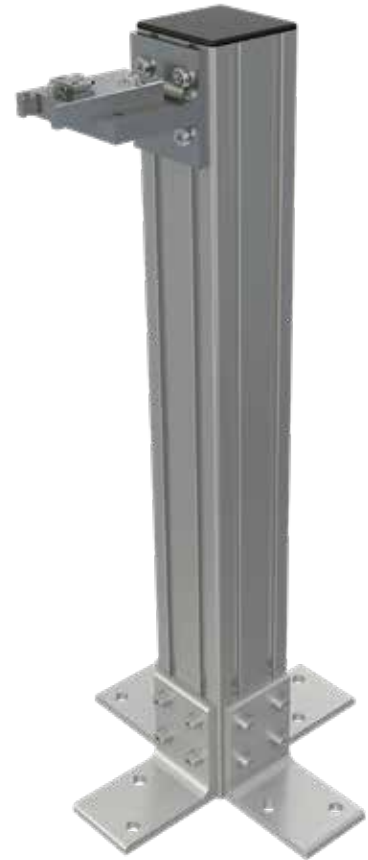

Base pillar	Quantity of tool storage	Sensors/ connection	Order no.	ill.
H = 600 mm	1	-	K85750006	1
	1	1x PNP/ 1x M8	K85750007	-
	1	1x NPN/ 1x M8	K85750008	-
H = 600 mm	2	-	K85750009	2
	2	2x PNP/ 2x M8	K85750010	-
	2	2x NPN/ 2x M8	K85750011	-

Technical data for the single components can be found on page 26.



iii.1

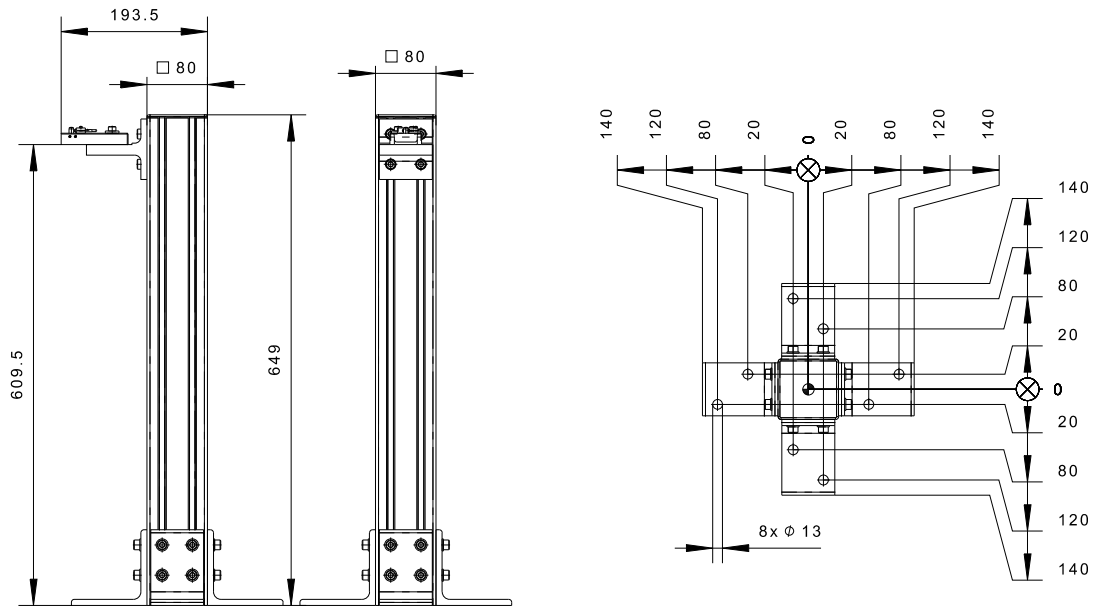

iii.2

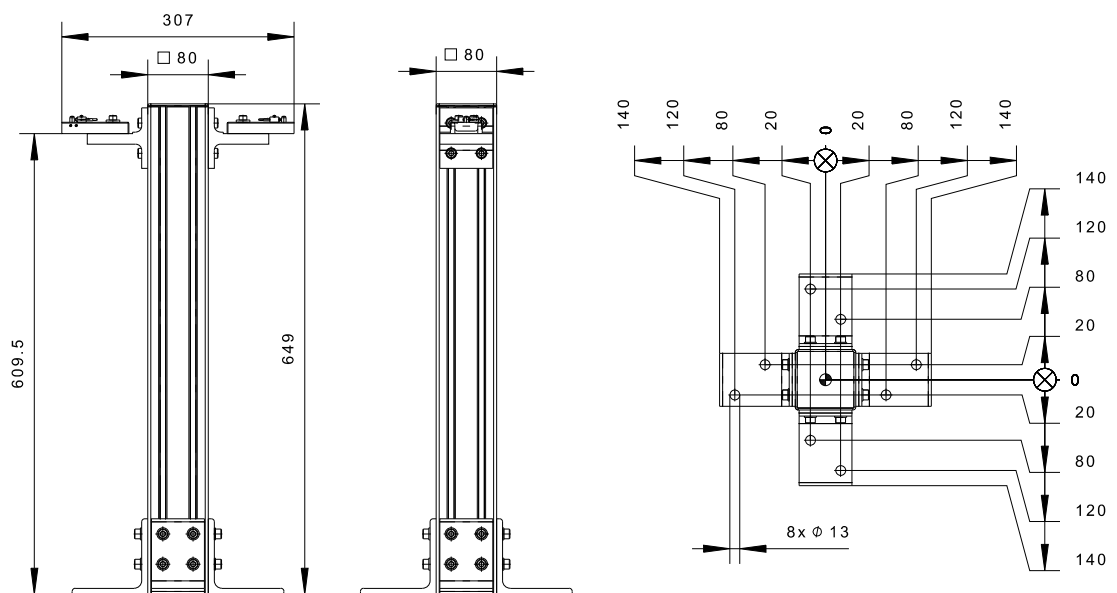

## MPS 015/025 TOOL STAND

### Tool stand upper part

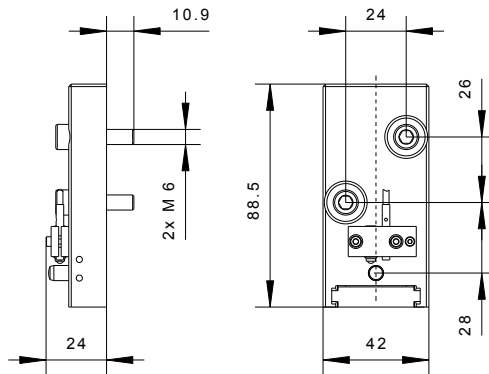

Order no.	Description	Sensors/ Connection
K85750023	Tool stand upper part, includes mounting materials	-
K85750024		1x PNP/ 1x M8
K85750025		1x NPN/ 1x M8

Tool hanger module for the tool side can be found on page 55.

### Rail adapter

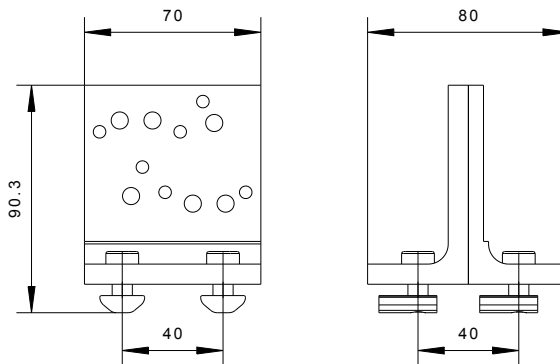

Order no.	Description
K81560512	Fixing bracket for attaching the top shelf to any profiles and supports

## Safety+ extension

ill.1

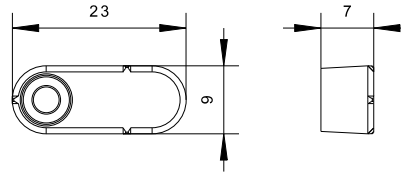

ill.2

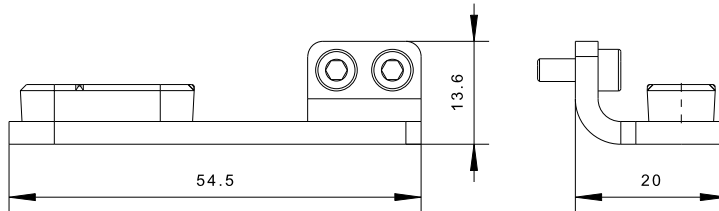

ill.3

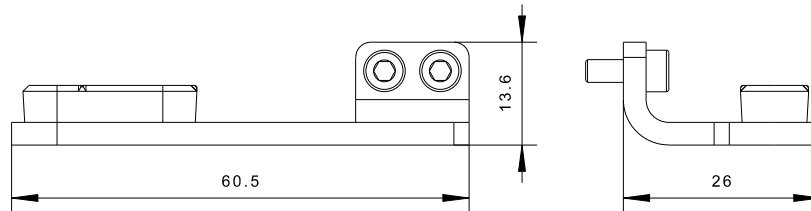

Order no.	Description	Suitable for	ill
B27586878	Safety+ actuating element for external tool stand system	MPS 015/025/035/055	1
K81579632	Tool stand Safety+ actuation element for use on Stäubli tool stand upper part	MPS 015	2
K81579633		MPS 025	3

The robot-side Safety+ modules can be found on page 56.

## Tool support

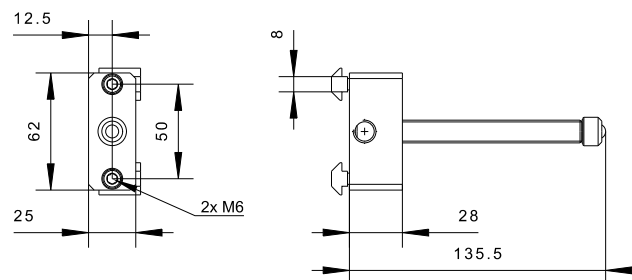

Order no.	Description
K85555070	Universal tool support for the deposited tool at the tool stand

## MPS 035 COMPLETE

# MPS 035/1

For handling and gripping applications

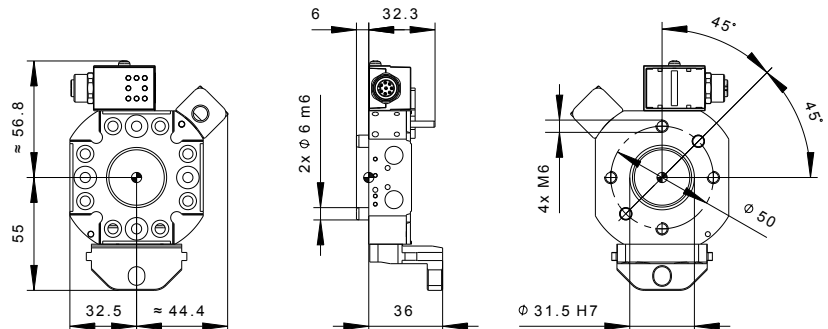
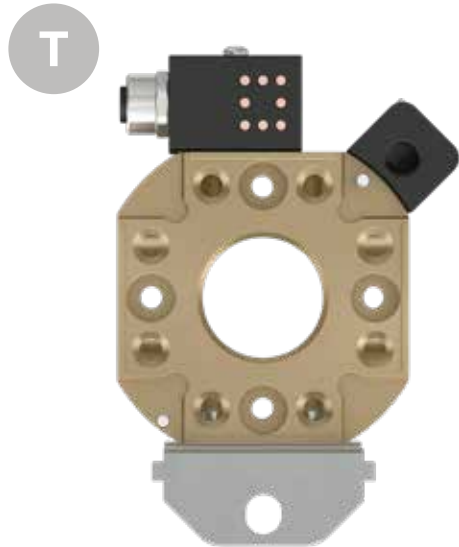
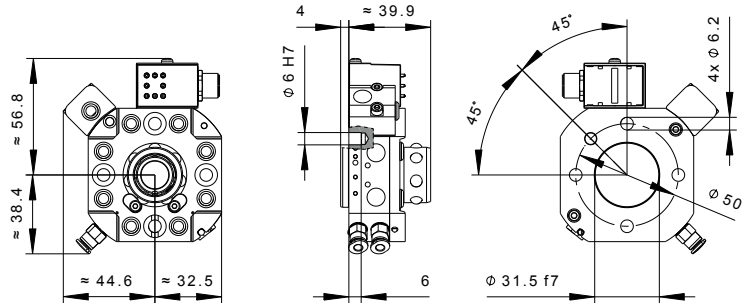

	Order no.	Unlock/ lock port	Pneumatic pass-through		Data and signal transfer		Sensors/ connection
			Quantity	Size	Connection	Pole	
R	MPS035RO-0000-PG-6A8C-00-0000-D2S0	2x Push-lock hose-Ø 4 mm	5	G 1/8	M12	8	–
	MPS035RC-0000-PG-6A8C-00-0000-D2S0						3x PNP/ 3x M8
	MPS035RG-0000-PG-6A8C-00-0000-D2S0						3x NPN/ 3x M8
T	MPS035TO-0000-PG-6A8C-00-0000-D2S0	–	5	G 1/8	M12	8	–

Technical data for the base unit on the robot and tool sides can be found on page 32.

Technical data for all transfer modules can be found from page 38 onwards.

Transfer modules with other threaded and plug-in connections can be individually adapted at any time via our simple configuration system (see page 30) to suit your individual requirements.

MPS 055 COMPLETE

# MPS 055/1

For handling and gripping applications

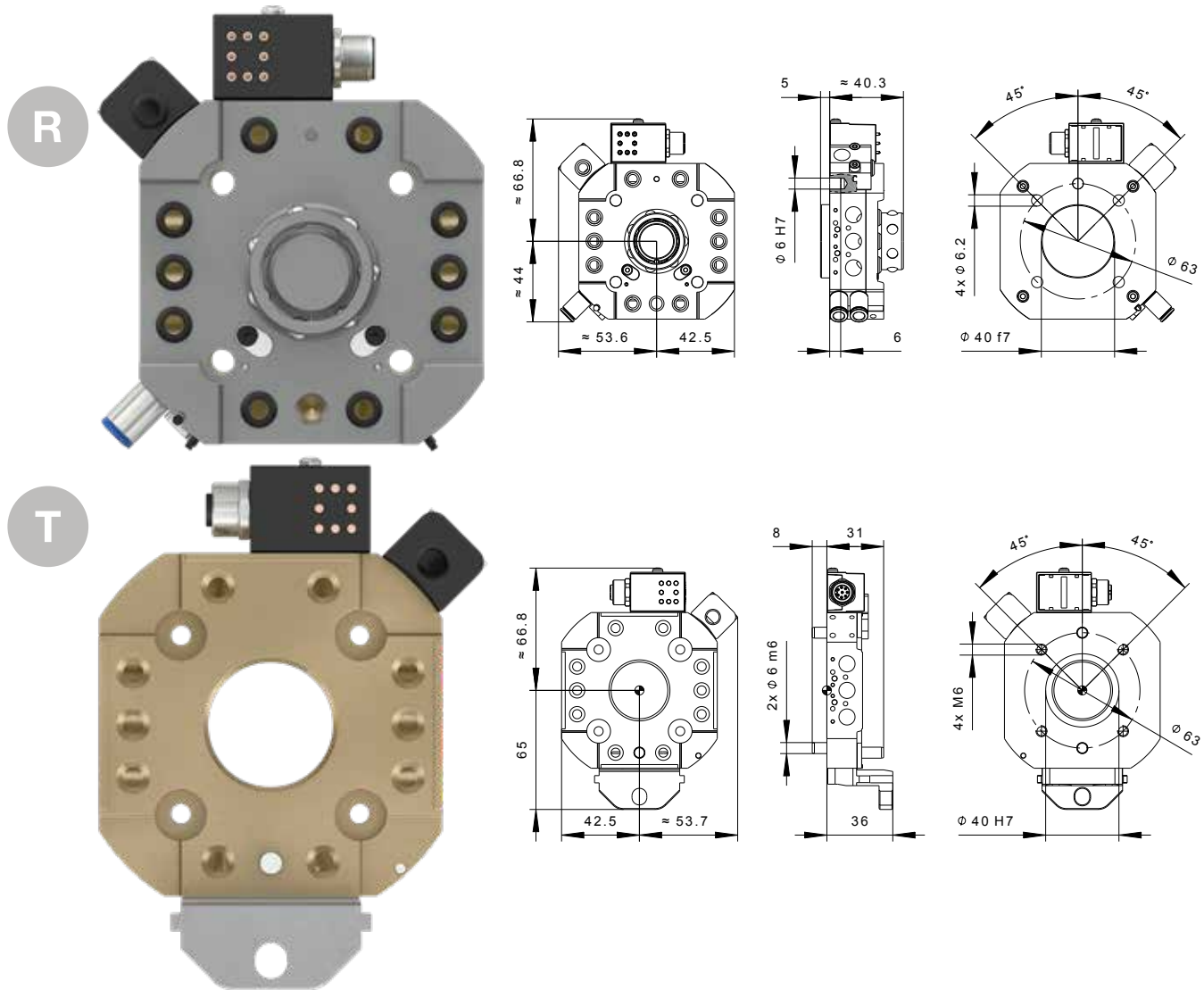

	Order no.	Unlock/ lock port	Pneumatic pass-through		Data and signal transfer		Sensors/ connection
			Quantity	Size	Connection	Pole	
R	MPS055RO-0000-PG-6A8C-00-0000-D2S0	2x Push-lock hose-Ø 6 mm	7	G 1/8	M12	8	-
	MPS055RC-0000-PG-6A8C-00-0000-D2S0						3x PNP/ 3x M8
	MPS055RG-0000-PG-6A8C-00-0000-D2S0						3x NPN/ 3x M8
T	MPS055TO-0000-PG-6A8C-00-0000-D2S0	-	7	G 1/8	M12	8	-

Technical data for the base unit on the robot and tool sides can be found on page 33.

Technical data for all transfer modules can be found from page 38 onwards.

Transfer modules with other threaded and plug-in connections can be individually adapted at any time via our simple configuration system (see page 30) to suit your individual requirements.

MPS 035/055 MODULAR

# Four easy steps to your modular solution

Take advantage of the technological diversity that is offered by Stäubli's modular product concept exactly where you need it. Configure your perfect tool changing system in just a few steps.

When using electrical modules, the module locations at the system corners of the cable outlets may not be occupied. Also cable outlets of two electrical modules facing each other are not possible.

Assignment of the module spaces at the system corners only possible with payload sizes MPS 035/055 possible. For MPS 015/025 see page 20.

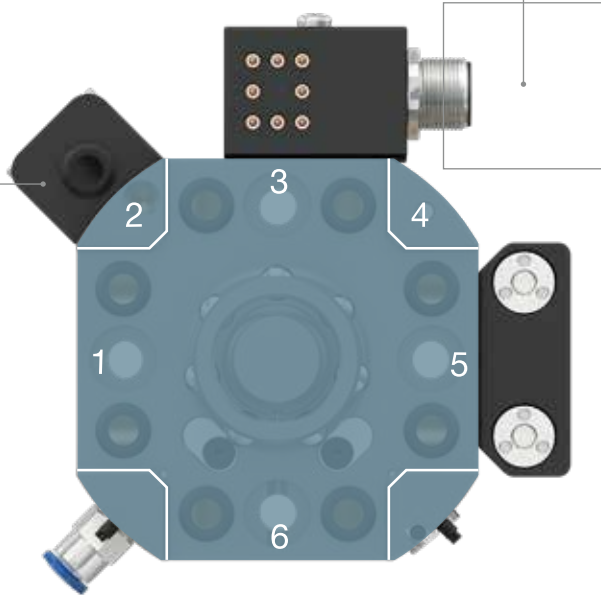

**1** Choose your **base unit** (page 32/33) and note the Module order code.

**2** Select your **transfer modules** (as of page 38). Place the modules at the module positions 1 to 6 by entering the module order code. Please note:

- For electrical modules, mark the direction of the cable outlet with C.
- Position 5: Safety+ module only possible at this position.
- Position 6: Tool hanger module D2S0 only possible at this position.
- Position 6: Electrical modules cannot be placed at this position.
- Mark unused module positions with 00 or 0000.

M P S 0 3 S R C - 0 0 0 0 - P G - 6 A 8 C - 0 0 - R 2 G 8 - D 2 S 0

Base unit robot side                          1                          2                          3                          4                          5                          6

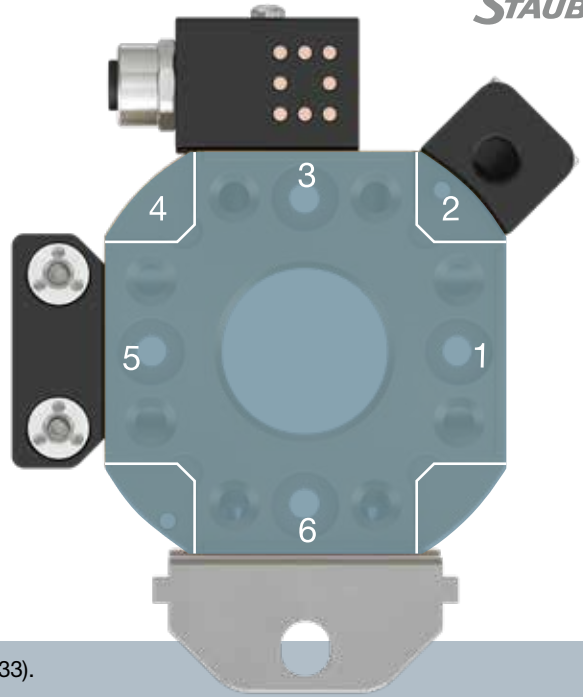

T

3

Select the appropriate **base unit** for your tool side (from page 32/33).  
Transfer the Module order codes of the **transfer modules** corresponding to the robot side.

M P S 0 3 S T 0 - 0 0 0 0 - P G - 6 A 8 C - 0 0 - R 2 G 8 - D 2 S 0

Base unit tool side
1
2
3
4
5
6

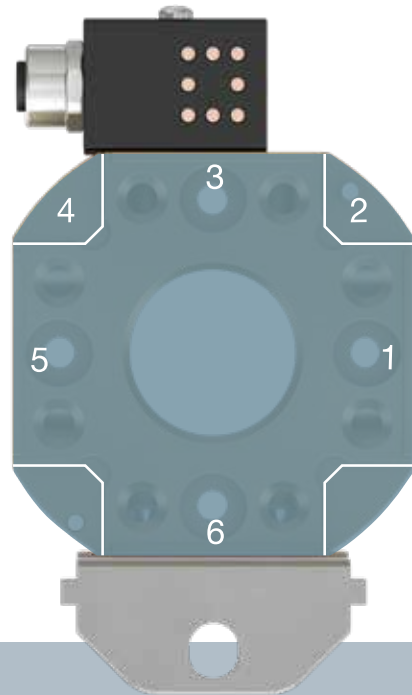

T

4

**Reduce your investment** by varying your tool side and removing any transfer modules that aren't needed (Replace Module order code with 00 or 0000).

M P S 0 3 S T 0 - 0 0 0 0 - 0 0 - 6 A 8 C - 0 0 - 0 0 0 0 - D 2 S 0

Base unit tool side
1
2
3
4
5
6

## MPS 035 MODULAR

# MPS 035 base unit robot and tool side

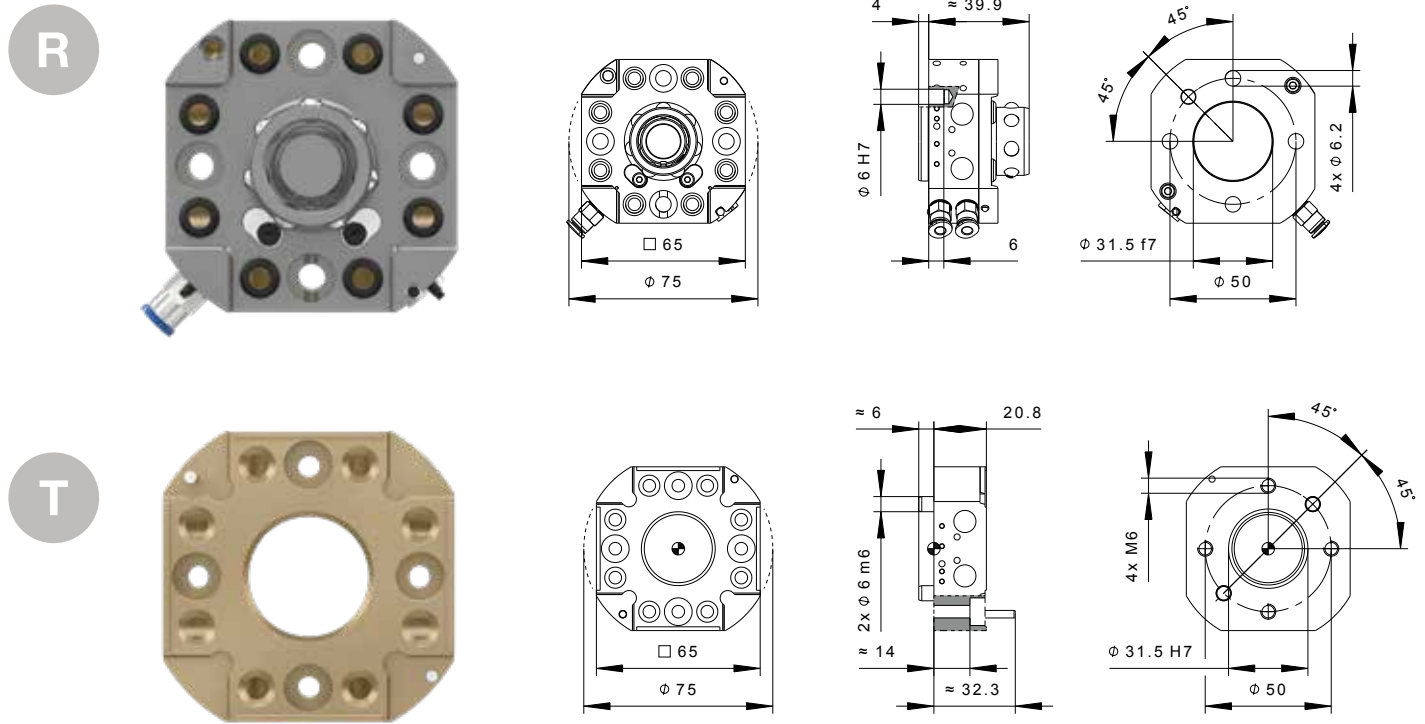

	Order no.	Pitch circle diameter (PCD)	Bending moment	Torsional moment	Operating pressure	Unlock/lock port	Pneumatic pass-through		Sensors/Connection	Module order code					
							Quantity	Size							
R	K81557767	Ø 50 mm	80 Nm	80 Nm	0.45-1.0 MPa	2x Push-lock hose-Ø 4 mm	8	G 1/8	-	MPS035RO					
	K81557770								3x PNP/ 3x M8	MPS035RC					
	K81557773								3x NPN/ 3x M8	MPS035RG					
	K81557768													-	MPS035RA
	K81557771											8	NPT 1/8	3x PNP/ 3x M8	MPS035RE
	K81557774													3x NPN/ 3x M8	MPS035RH
	K81557769													-	MPS035RB
	K81557772											8	Rc 1/8	3x PNP/ 3x M8	MPS035RF
	K81557775													3x NPN/ 3x M8	MPS035RJ
T	K81557940	Ø 50 mm	80 Nm	80 Nm	-	-	8	G 1/8	-	MPS035TO					
	K81557941				-	-		NPT 1/8	-	MPS035TA					
	K81557942				-	-		Rc 1/8	-	MPS035TB					



MPS 055 MODULAR

# MPS 055 base unit robot and tool side

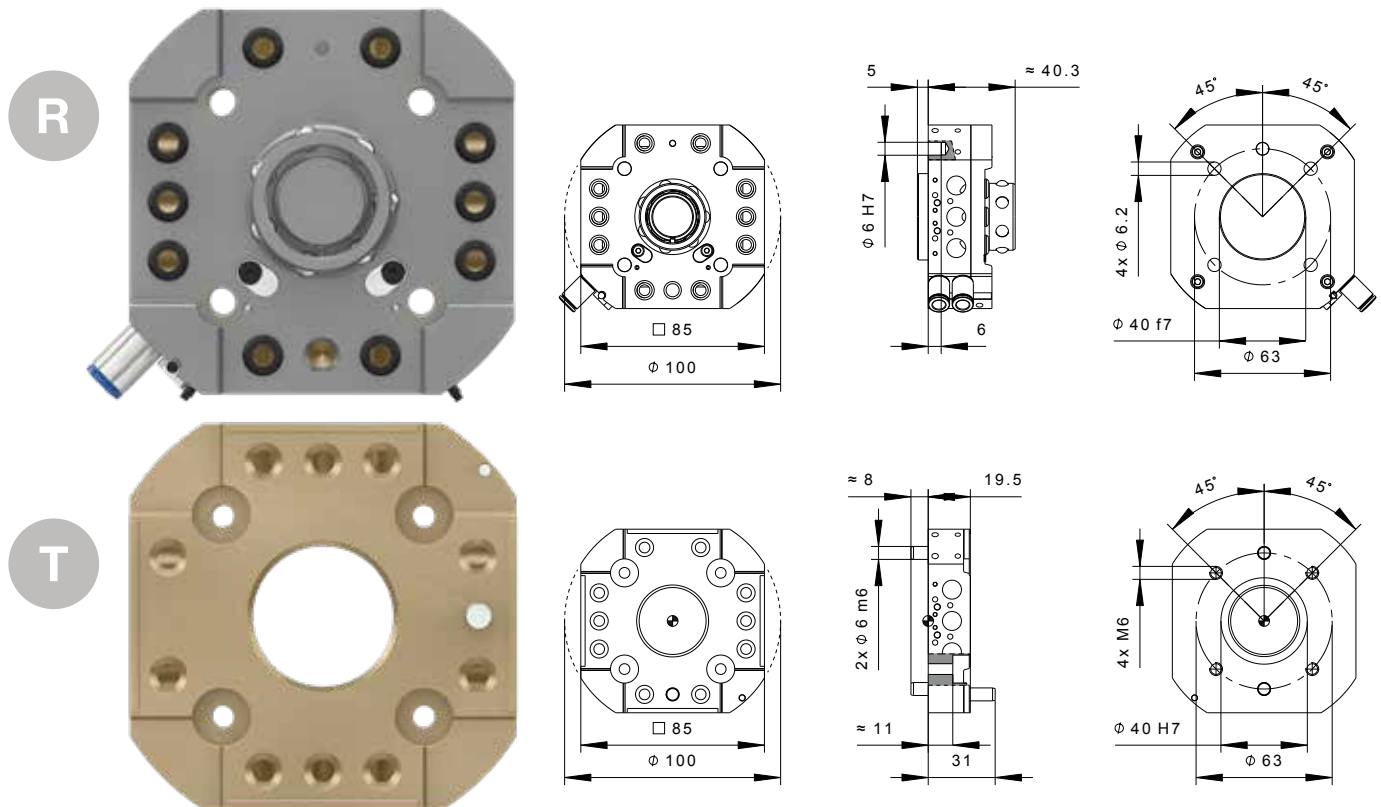

	Order no.	Pitch circle diameter (PCD)	Bending moment	Torsional moment	Operating pressure	Unlock/lock port	Pneumatic pass-through		Sensors/Connection	Module order code					
							Quantity	Size							
R	K81557776	Ø 63 mm	145 Nm	145 Nm	0.45-1.0 MPa	2x Push-lock hose-Ø 6 mm	10	G 1/8	-	MPS055RO					
	K81557779								3x PNP/ 3x M8	MPS055RC					
	K81557782								3x NPN/ 3x M8	MPS055RG					
	K81557777													-	MPS055RA
	K81557780											10	NPT 1/8	3x PNP/ 3x M8	MPS055RE
	K81557783													3x NPN/ 3x M8	MPS055RH
	K81557778													-	MPS055RB
	K81557781											10	Rc 1/8	3x PNP/ 3x M8	MPS055RF
	K81557784													3x NPN/ 3x M8	MPS055RJ
T	K81557943	Ø 63 mm	145 Nm	145 Nm	-	-	10	G 1/8	-	MPS055TO					
	K81557944				-	-		NPT 1/8	-	MPS055TA					
	K81557945				-	-		Rc 1/8	-	MPS055TB					

## MPS 035/055 TOOL STAND

# MPS 035/055 – Tool stand

Flexibility and efficiency through integrated tool storage system

**Stäubli consistently applies the modularity of the MPS series to storage systems. Due to the individual components used in the design, there is great scope for flexible process adaptation.**

- **Flexibility:** With the single system components, your own individual storage solutions can be compiled and easily integrated into existing systems.
- **Modularity:** Choose between preconfigured complete systems or single modules that can be used directly with standard profile solutions.
- **Longevity:** The floating bearing in the upper part of the system ensures that the tool is optimally held in the drop-off position. The load on the components is minimized.
- **Economical:** One tool storage system that can be used as a vertical or 90° rotated solution offers a wide range of possible uses.
- **Process reliability:** A mechanical fixation with adjustable retention force enables additional securing of the dropped -off tools. The system can optionally be expanded with integrated sensors for status indication.

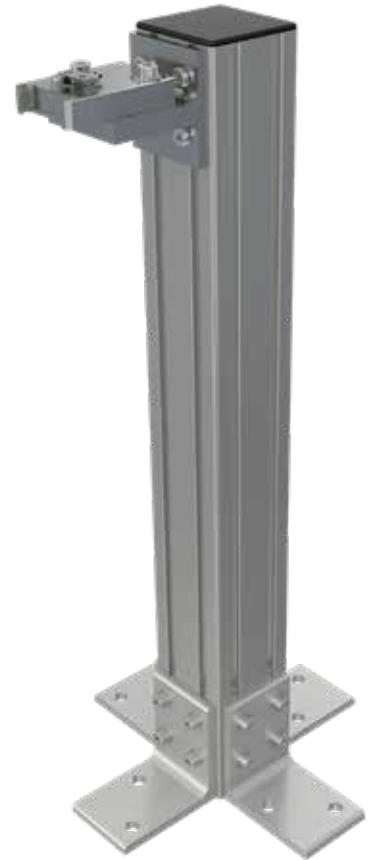

Base pillar	Quantity of tool storage	Sensors/ connection	Order no.	ill.
H = 600 mm	1	-	K85750012	1
	1	1x PNP/ 1x M8	K85750013	-
	1	1x NPN/ 1x M8	K85750014	-
H = 600 mm	2	-	K85750015	2
	2	2x PNP/ 2x M8	K85750016	-
	2	2x NPN/ 2x M8	K85750017	-

Technical data for all the single components can be found on page 36.

iii.1

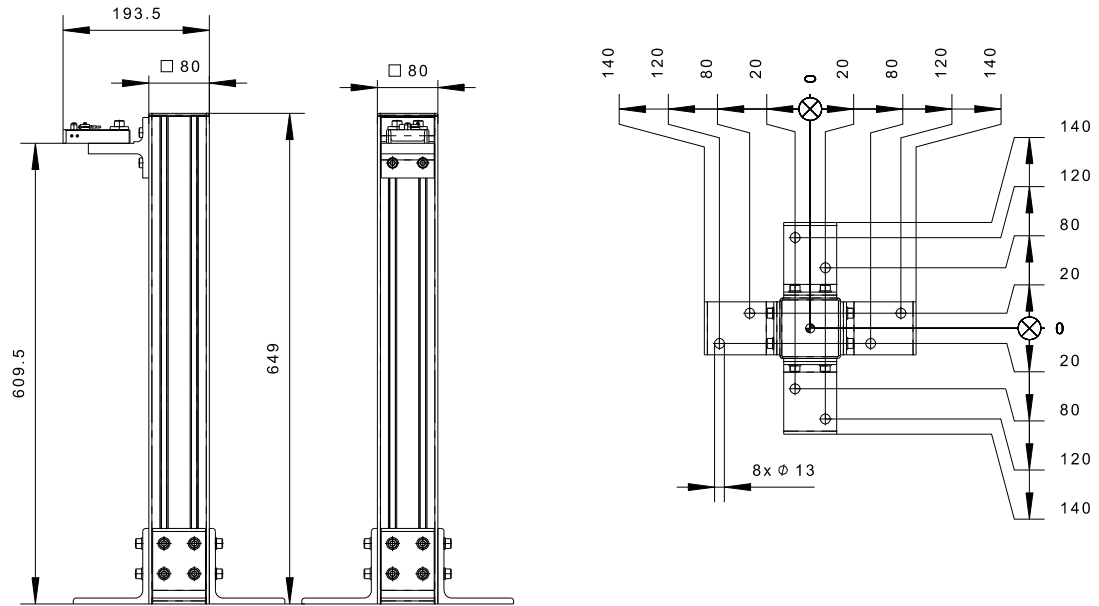

iii.2

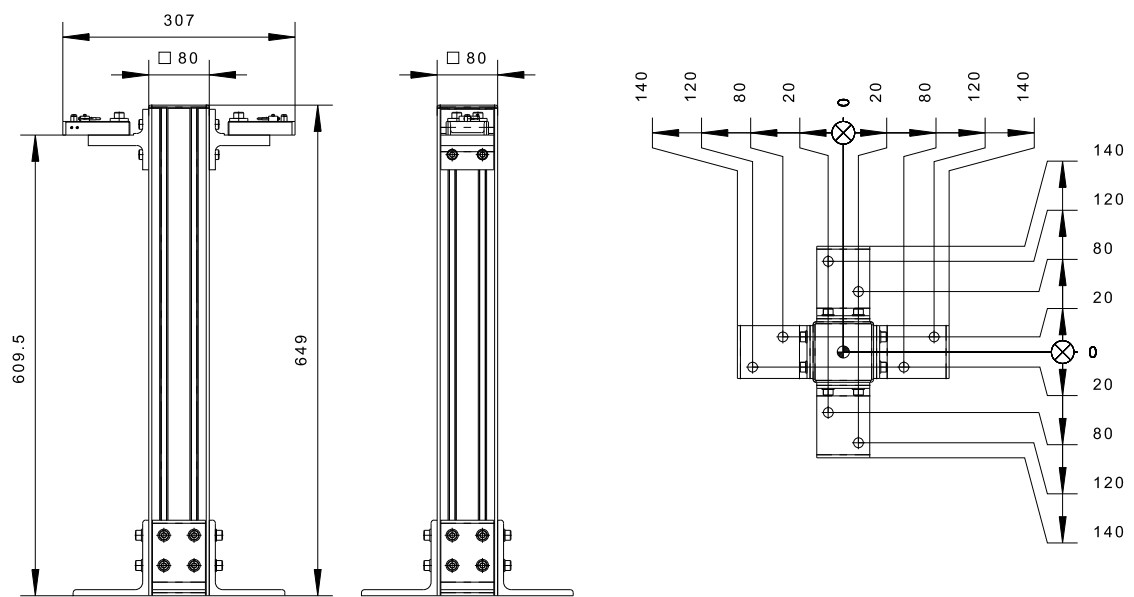

## MPS 035/055 TOOL STAND

### Tool stand upper part

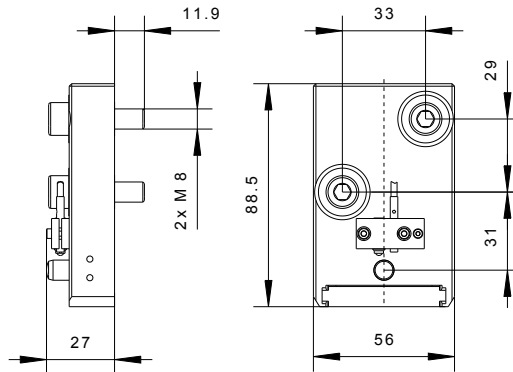

Order no.	Description	Sensors/ Connection
K85750026		-
K85750027	Tool stand upper part, includes mounting materials	1x PNP/ 1x M8
K85750028		1x NPN/ 1x M8

Tool hanger module for the tool side can be found on page 55.

### Rail adapter

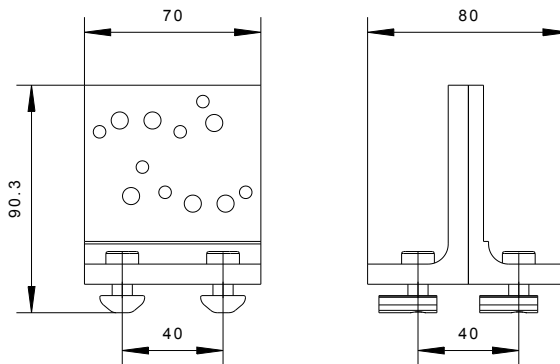

Order no.	Description
K81560512	Fixing bracket for attaching the top shelf to any profiles and supports

## Safety+ extension

ill.1

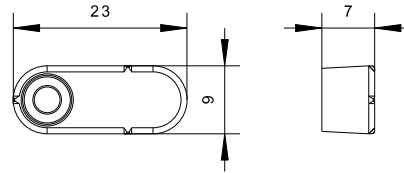

ill.2

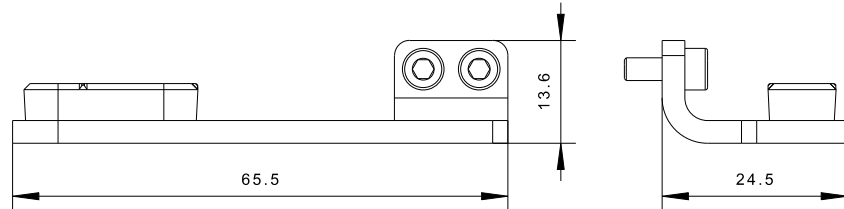

ill.3

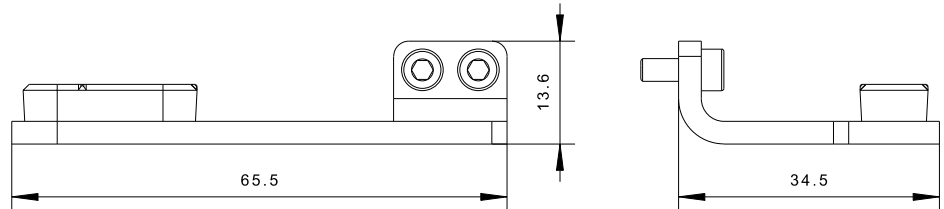

Order no.	Description	Suitable for	ill
B27586878	Safety+ actuating element for external tool stand system	MPS 015/025/035/055	1
K81579634	Tool stand Safety+ actuation element for use on Stäubli tool stand upper part	MPS 035	2
K81579635		MPS 055	3

The robot-side Safety+ modules can be found on page 56.

## Tool support

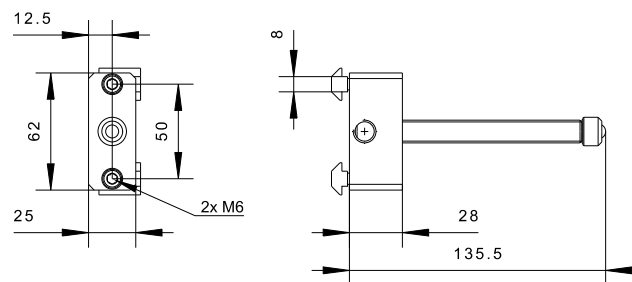

Order no.	Description
K85555070	Universal tool support for the deposited tool at the tool stand

MPS 015/025/035/055 TRANSFER MODULES

# Transfer modules for your production technology

pneumatic and vacuum

pneumatic

	FTM - free passage				ROK - Valve one-sided		
	4x Ø 2.5 mm	5x Ø 2.5 mm	1x Ø 5 mm	2x Ø 5 mm	1x Ø 2 mm	2x Ø 2 mm	3x Ø 2 mm
MPS 015		-	-		-		-
MPS 025		-	-		-		-
MPS 035		-					-
MPS 055	-			-		-	
	page 40	page 41	page 42	page 43	page 44	page 45	page 45

electrical module for data and signal transfer

tool stand

Safety+

Shielding and grounding	Tool coding	data and signal transfer		RFID	Adapter for tool stand	Safety+ module
1x 10 mm <sup>2</sup>	3x Initiator	M8, M12 and D-SUB	DuraDock Vision, Ultra, Giga10	IO Link	Tool hanger module	Touchless safety switch
●	●	●	●	-	●	●
●	●	●	●	-	●	●
●	●	●	●	●	●	●
●	●	●	●	●	●	●
page 46	page 47	page 48	page 50	page 54	page 55	page 56

## MPS 015/025/035/055 TRANSFER MODULES

# FTM transfer modules for pneumatics and vacuum

### Technical description

- free passage guarantees high volume flows with low flow resistance
- suitable for the transfer of up to 90% vacuum
- extremely robust design guaranteeing a high number of docking cycles

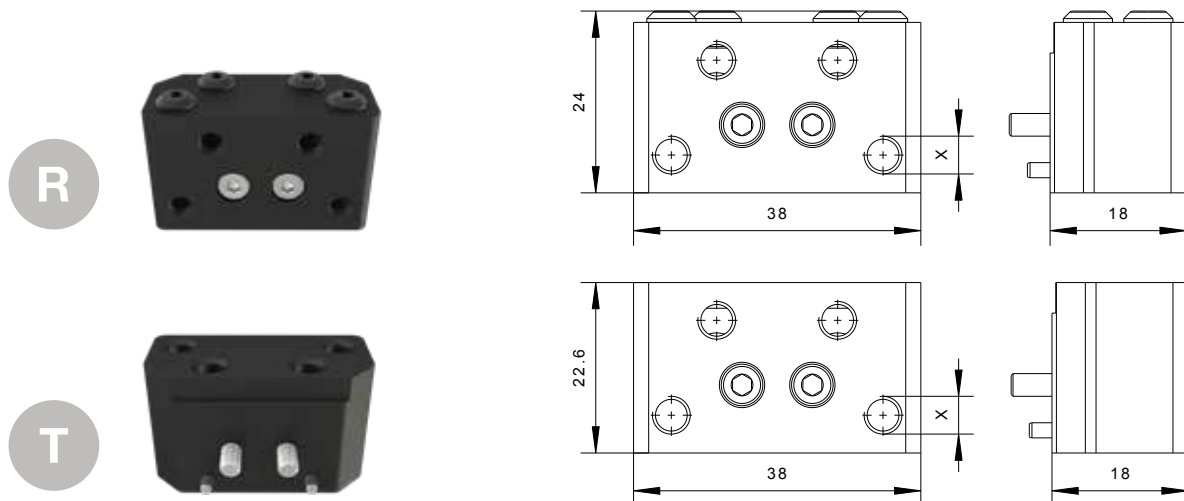

MPS 015

MPS 025

MPS 035

	Order no.	Nominal width	Circuits	Valve	Pressure (max.)	Flow rate (max.)	Connection (X)	Module order code
R	K81579419	2.5 mm	4	Free passage	1.0 MPa	8.7 Nm <sup>3</sup> /h	M5	P4M5
T	K81579420							



R

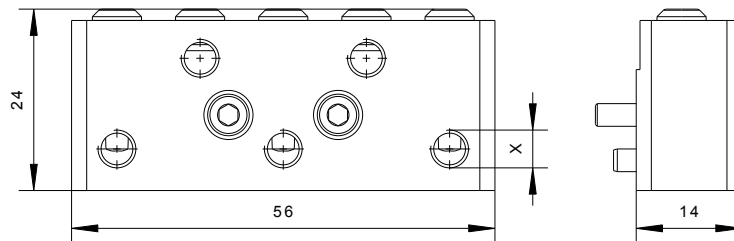

T

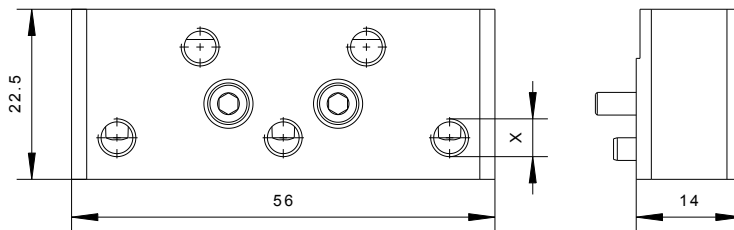

**MPS 055**

	Order no.	Nominal width	Circuits	Valve	Pressure (max.)	Flow rate (max.)	Connection (X)	Module order code
R	K81579421	2.5 mm	5	Free passage	1.0 MPa	8.7 Nm <sup>3</sup> /h	M5	P5M5
T	K81579422							

## MPS 015/025/035/055 TRANSFER MODULES

R

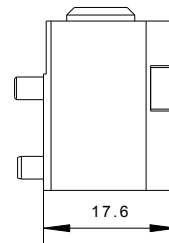
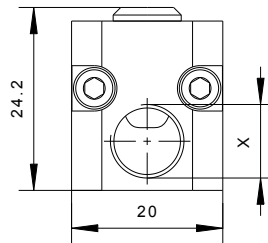

T

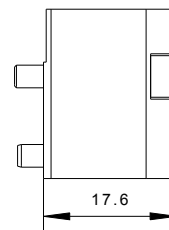
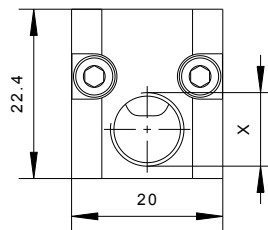

MPS 035

MPS 055

	Order no.	Nominal width	Circuits	Valve	Pressure (max.)	Flow rate (max.)	Connection (X)	Module order code
R	K81579423	5.0 mm	1	Free passage	1.0 MPa	37.32 Nm <sup>3</sup> /h	G 1/8	PG
T	K81579424							
R	K81579425	5.0 mm	1	Free passage	1.0 MPa	37.32 Nm <sup>3</sup> /h	NPT 1/8	PN
T	K81579426							
R	K81579427	5.0 mm	1	Free passage	1.0 MPa	37.32 Nm <sup>3</sup> /h	Rc 1/8	PR
T	K81579428							

R



T

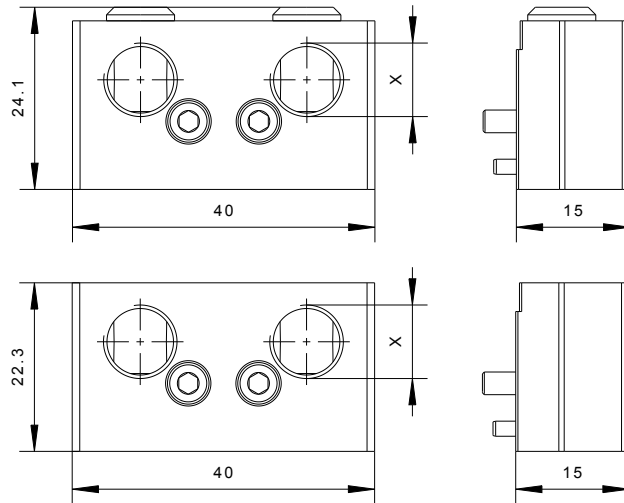

MPS 015	MPS 025	MPS 035
---------	---------	---------

	Order no.	Nominal width	Circuits	Valve	Pressure (max.)	Flow rate (max.)	Connection (X)	Module order code
R	K81579429	5.0 mm	2	Free passage	1.0 MPa	37.32 Nm <sup>3</sup> /h	G 1/8	P2G8
T	K81579430							
R	K81579431	5.0 mm	2	Free passage	1.0 MPa	37.32 Nm <sup>3</sup> /h	NPT 1/8	P2N8
T	K81579432							
R	K81579433	5.0 mm	2	Free passage	1.0 MPa	37.32 Nm <sup>3</sup> /h	Rc 1/8	P2R8
T	K81579434							

## MPS 015/025/035/055 TRANSFER MODULES

# ROK transfer modules for pneumatics

### Technical description

- quick and easy replacement of the couplings if necessary
- large volume flows with low flow resistance
- extremely robust design guaranteeing a high number of docking cycles

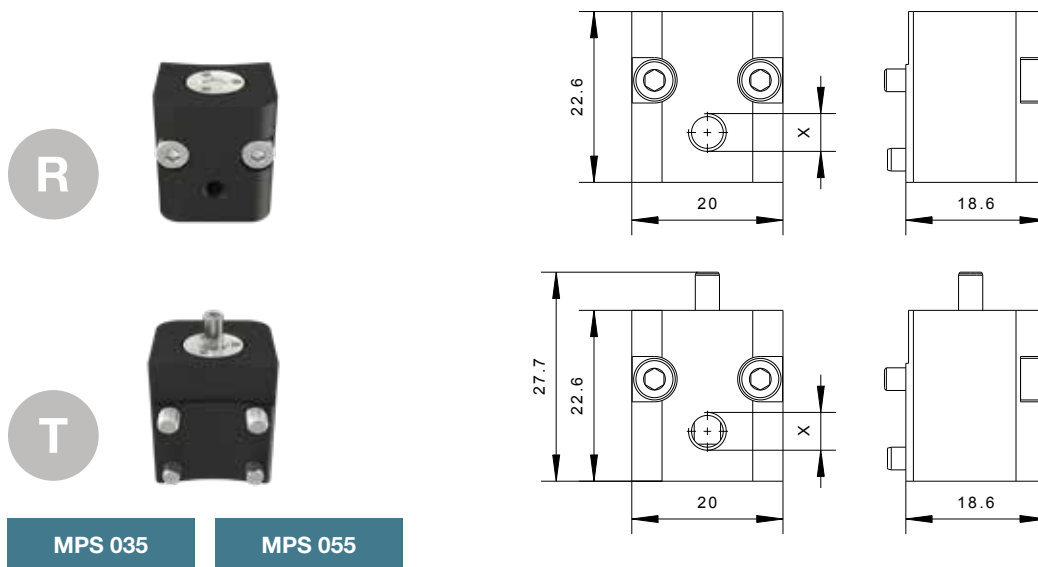

MPS 035

MPS 055

	Order no.	Nominal width	Circuits	Valve	Pressure (max.)	Flow rate (max.)	Connection (X)	Module order code
R	K81579435	2.0 mm	1	One-sided	1.0 MPa	7.90 Nm <sup>3</sup> /h	M5	RM
T	K81579436			Free passage				

R

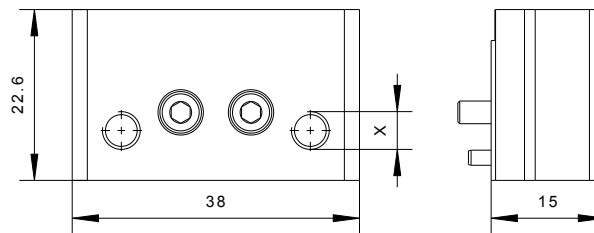

T

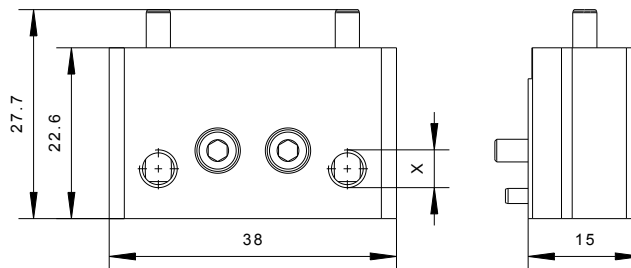

MPS 015

MPS 025

MPS 035

	Order no.	Nominal width	Circuits	Valve	Pressure (max.)	Flow rate (max.)	Connection (X)	Module order code
R	K81579437	2.0 mm	2	One-sided	1.0 MPa	7.90 Nm <sup>3</sup> /h	M5	R2M5
T	K81579438			Free passage				

R

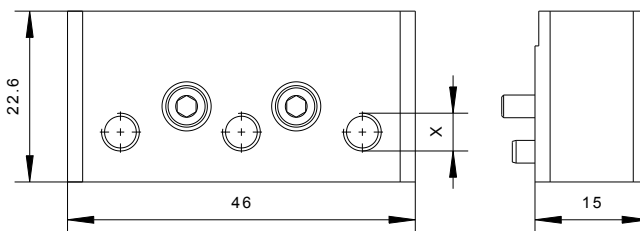

T

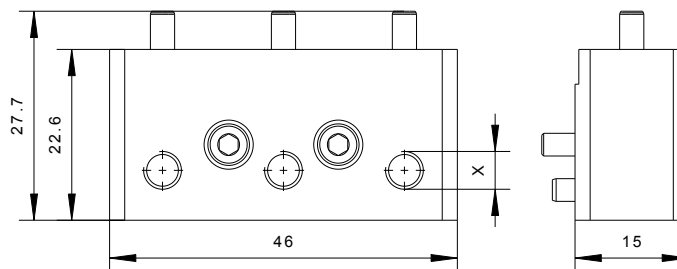

MPS 055

	Order no.	Nominal width	Circuits	Valve	Pressure (max.)	Flow rate (max.)	Connection (X)	Module order code
R	K81579439	2.0 mm	3	One-sided	1.0 MPa	7.90 Nm <sup>3</sup> /h	M5	R3M5
T	K81579440			Free passage				

## MPS 015/025/035/055 TRANSFER MODULES

# Ground pin modules for shielding and grounding connection

### Technical description

- excellent power transmission with patented Stäubli MULTILAM technology
- Stäubli “Floating Contact Technology” guarantees wear-free connections
- light weight

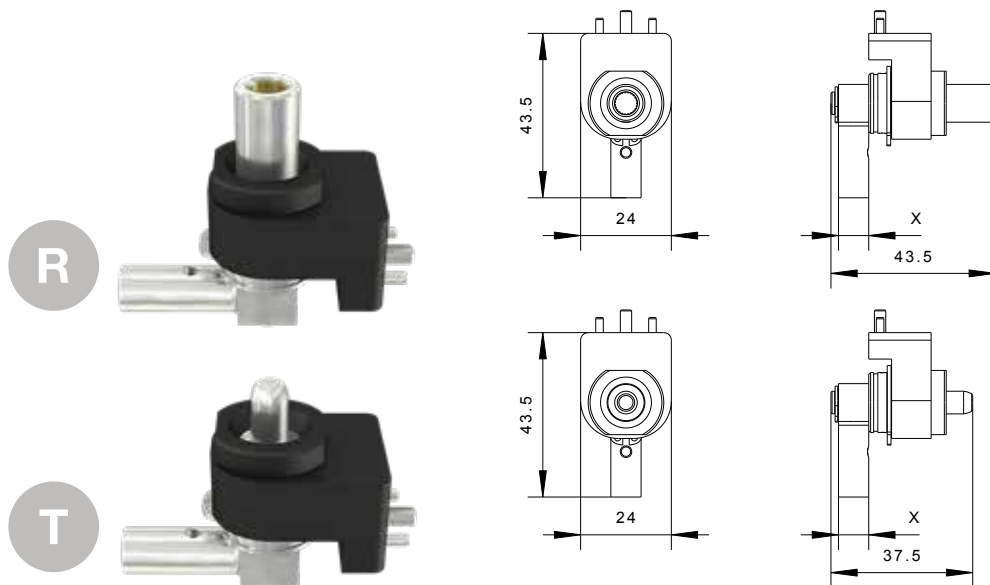

MPS 015

MPS 025

MPS 035

MPS 055

	Order no.	Transmission poles	Voltage/current	Cable cross-section	Connection (X)	Module order code
R	K81579453	1	55 VAC/ 75 A	10 mm <sup>2</sup>	Crimp barrel	P1E1
T	K81579454					

# Transfer modules for tool coding

## Technical description

- individual coding of tool sides
- three inductive proximity switches on the robot side
- mechanical adjustment of the coding with an adjusting screw on the tool side

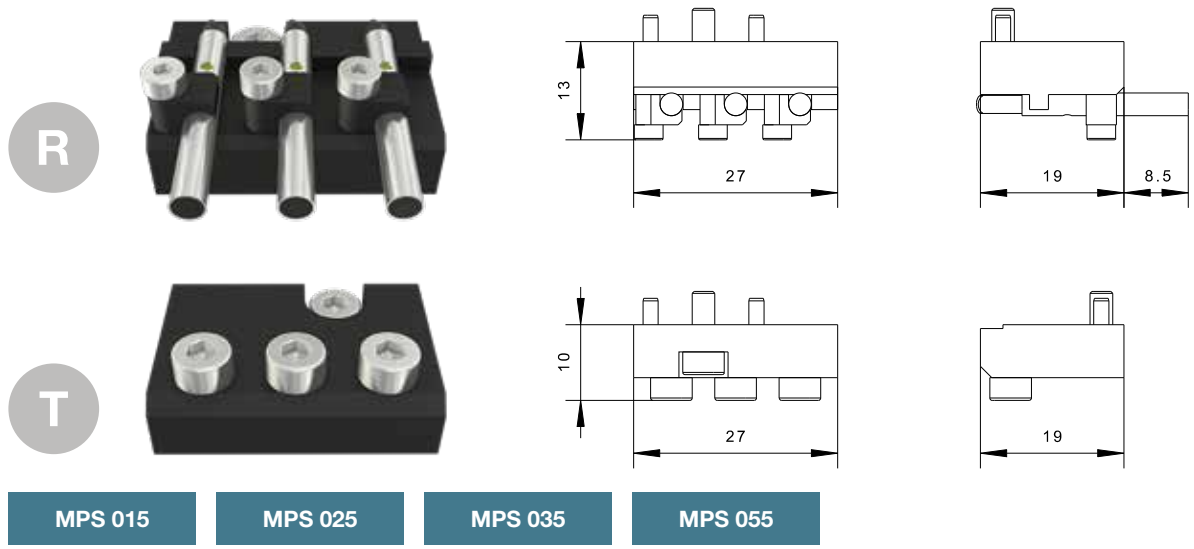

MPS 015      MPS 025      MPS 035      MPS 055

	Order no.	Sensors/ connection	Module order code
R	K81579676	PNP/ 3x M8 3-pin - cable length 0.3 m	I3PP
T	K81579678	Mechanical opposing side	
R	K81579677	NPN/ 3x M8 3-pin - cable length 0.3 m	I3NN
T	K81579678	Mechanical opposing side	

## MPS 015/025/035/055 TRANSFER MODULES

# Electrical modules for data and signal transfer

### Technical description

- Plug & Play solution
- Proof printed circuit board against fail wiring
- light weight and compact design
- up to 100,000 docking cycles

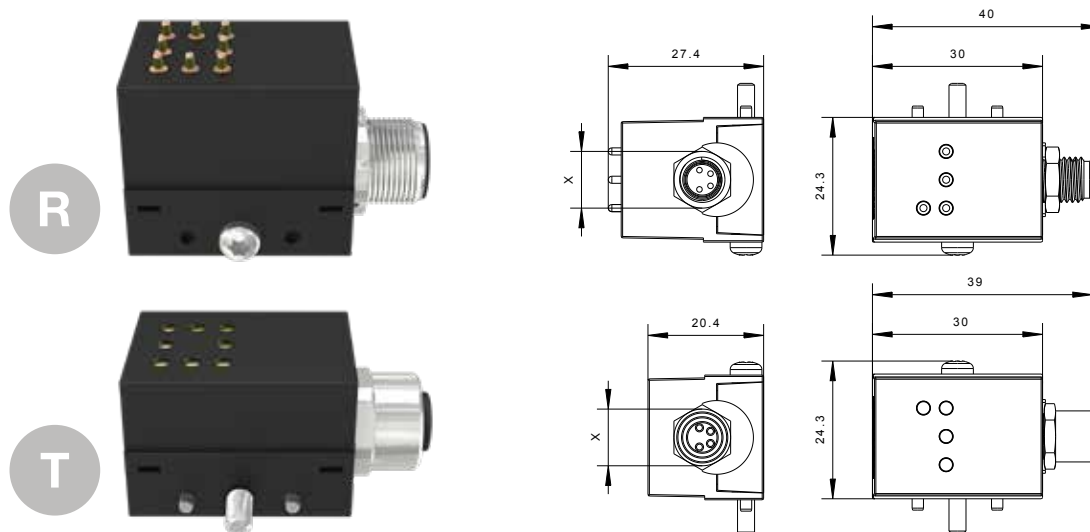

MPS 015

MPS 025

MPS 035

MPS 055

	Order no.	Pole	Connection(X)	Coding	Voltage/current	Protection class	Description	Module order code
R	33004589	3	M8-pin	R	25 VAC*/ 60 VDC max. 4 A	IP30	-	C4R3C
T	33004590		M8-socket					
R	33004148	4	M8-pin	A	25 VAC*/ 60 VDC max. 4 A	IP30	-	C4A4C
T	33004149		M8-socket					
R	33004151	4 + Shield	M12-socket	D	25 VAC*/ 60 VDC max. 4 A	IP30	ProfiNet/ Ethernet	C6D4C
T	33004150		M12-socket					
R	33004146	5	M12-pin	B	25 VAC*/ 60 VDC max. 4 A	IP30	-	C6B5C
T	33004147		M12-socket					
R	33004153	8	M12-pin	A	25 VAC*/ 60 VDC max. 2 A	IP30	-	C6A8C
T	33004152		M12-socket					

\* max. 50 VAC touch-protected in coupled state.



# D-SUB transfer modules for signals and data

## Technical description

- lightweight & compact plastic housing
- multi-pole applications up to 15 poles or 26 poles
- up to 100,000 docking cycles

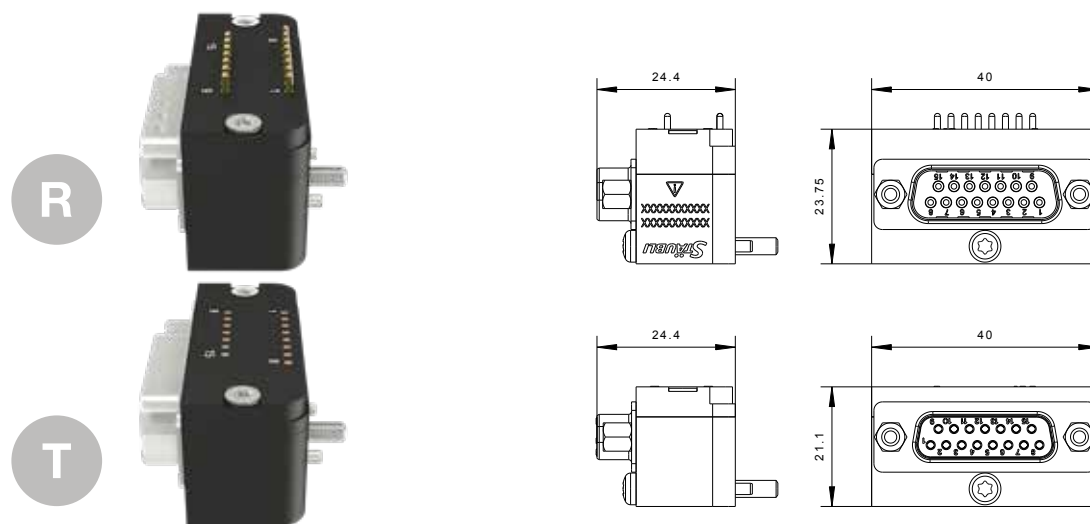

	Order no.	Pole	Connection	Coding	Voltage/current	Protection class	Module order code
R	33004433	15	D-SUB 15-pin	2-row	25 VAC*/ 60 VDC max. 2.6 - 5.5 A	IP30	EDSA
T	33004432		D-SUB 15-socket				
R	33004431	26	D-SUB 26-pin	3-row	25 VAC*/ 60 VDC max. 1.7 - 3.8 A	IP30	EDSB
T	33004430		D-SUB 26-socket				

\* max. 50 VAC touch-protected in coupled state.

## Accessories for connectors

	Order no.	Type	Connection type	Suitable for
R	B27598873	Socket board D-SUB 15	Solder Cup	EDSA
T	B27598874	Pin board D-SUB 15	Solder Cup	EDSA
R	B27598871	Socket board D-SUB 26	Solder Cup	EDSB
T	B27598872	Pin board D-SUB 26	Solder Cup	EDSB

## Accessories for housing

	Order no.	Type	Suitable for
	B27598876	Plastic housing D-SUB - straight cable output	EDSA/ EDSB
	K81453110	Plastic housing D-SUB - 90° cable output	EDSA/ EDSB

## MPS 015/025/035/055 TRANSFER MODULES

# DuraDock Vision transfer modules for camera applications

### Technical description

- lightweight plastic housing
- processing of analogue image and video signals
- suitable for RG 59 standard cable

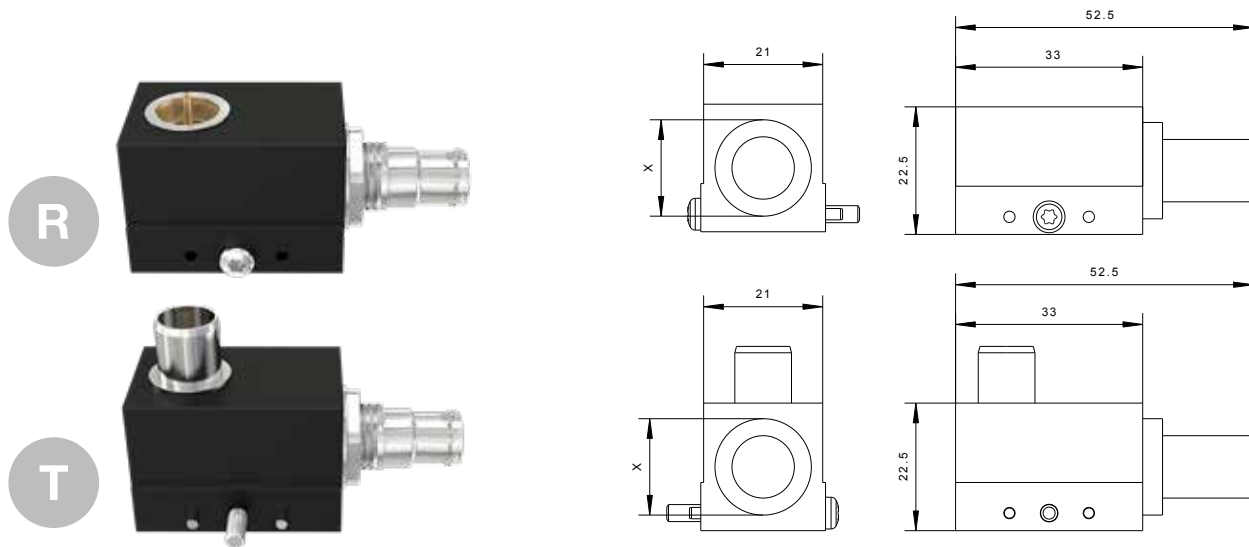

MPS 015

MPS 025

MPS 035

MPS 055

	Order no.	Pole	Connection (x)	Frequency	Impedance	Voltage/current	Protection class	Module order code
R	33004455	1	BNC	up to 500 MHz	75 Ohm	24 VDC - max. 1 A	IP30	C1B1C
T	33004454							

# DuraDock Ultra transfer modules for ultrasonic applications

## Technical description

- robust aluminum housing
- designed for the use of SHV - Safety High Voltage
- suitable for RG 58 standard cable

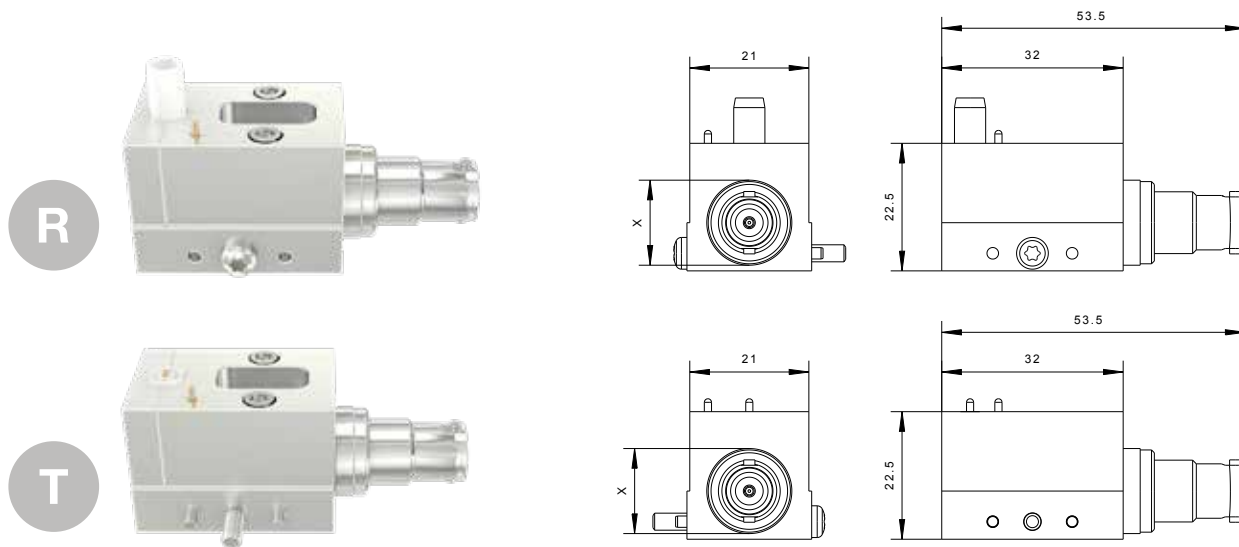

	Order no.	Pole	Connection (x)	Voltage / Frequency	Impedance	Current	Protection class	Module order code
R	33004425	1	SHV	1500 VDC up to 40 kHz 2000 VDC up to 30 kHz 3500 VDC*	50 Ohm	max. 10 A	IP30	C1H1C
T	33004424							

\* Up to 3500 V possible (at relative humidity 30%, ED 10% and frequency < 30 kHz).

## MPS 015/025/035/055 TRANSFER MODULES

# DuraDock Giga10 transfer modules for signals and data

### Technical description

- suitable for applications with Gigabit Ethernet
- suitable for docked camera systems
- up to 1,000,000 docking cycles



The tool weight must be at least 10 kg. Only one module per base unit is allowed.

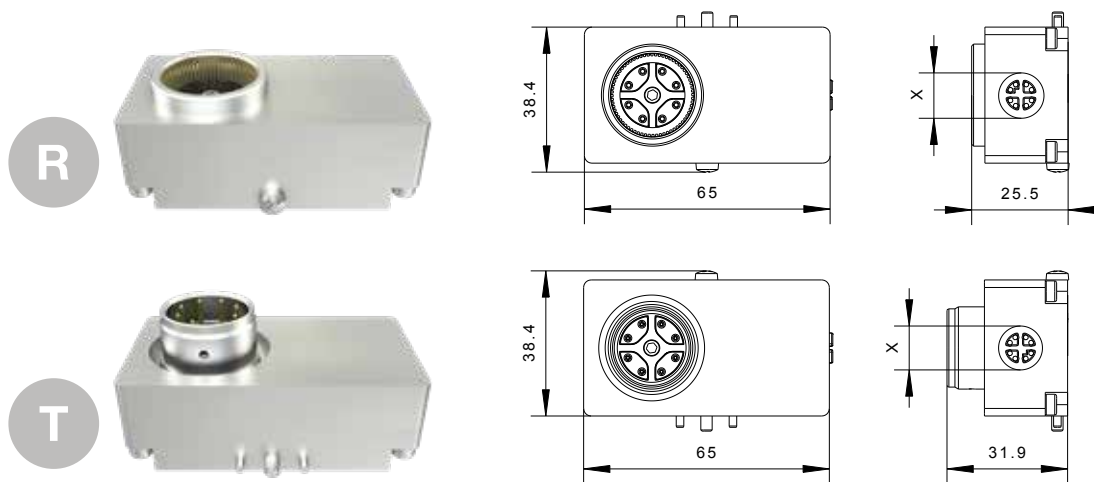

	Order no.	Pole	Connection (x)	Coding	Suitable for	Protection class	Description	Module order code
R	33004210	8	M12-socket	X	Network cable, Ethernet, CAT6A, 8 pin (10 GBit/s)	IP65	Pre-assembled and tested connector	C6X8
T	33004213							



## MPS 015/025/035/055 TRANSFER MODULES

# Transfer module for RFID

### Technical description

- detecting from objects
- IO-Link communication
- unlimited read cycles
- max. 100,000 write cycles

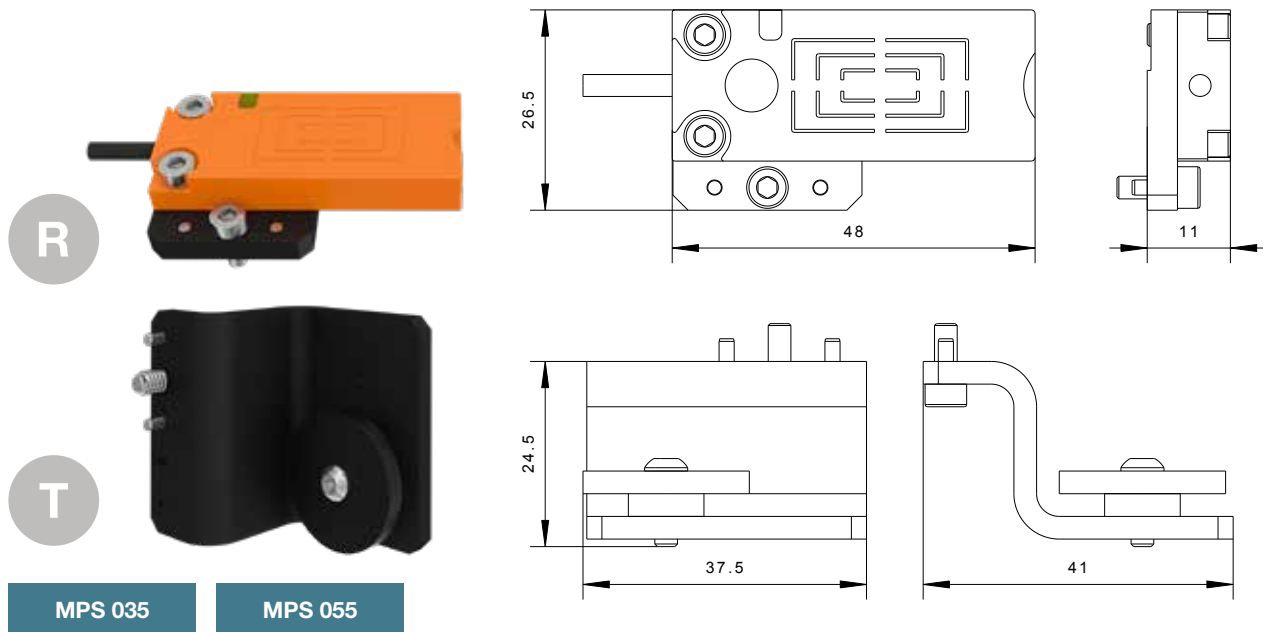

	Order no.	Pole	Connection	Coding	Operating voltage	Protection class	Description	Module order code
R	K81579458	3	M12-Pin	A	19.2 ... 28.8 VDC	IP67	RFID read/ write head	RFID
T	K81579459	-	-	-	-	IP68	RFID tag	

# Tool hanger module



MPS 015

MPS 025

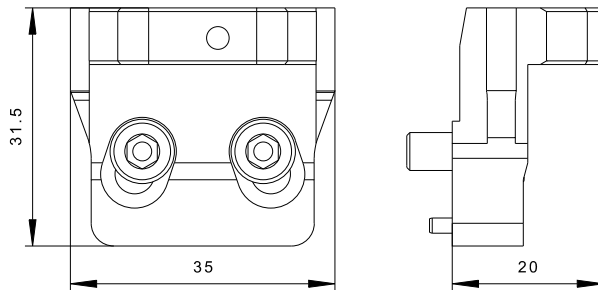

Order no.	Description	Module order code
K81579441	Tool hanger module for tool side mounting	D1S0



MPS 035

MPS 055

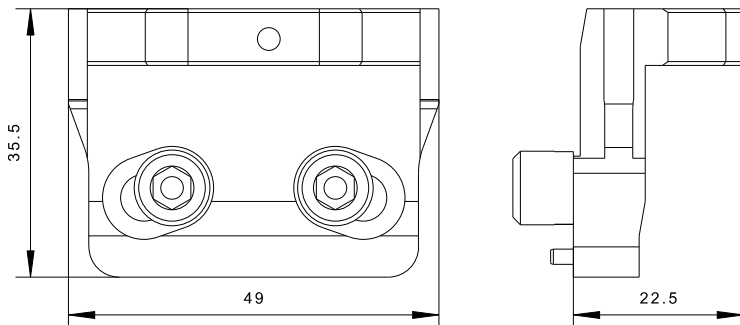

Order no.	Description	Module order code
K81579442	Docking module for tool side with G threads	D2S0
K81579443	Docking module for tool side with NPT threads	D2S1
K81579444	Docking module for tool side with Rc threads	D2S2

## MPS 015/025/035/055 TRANSFER MODULES

# Safety+ modules

### Technical description

- compact design
- touchless communication
- enables Performance Level d, Category 3

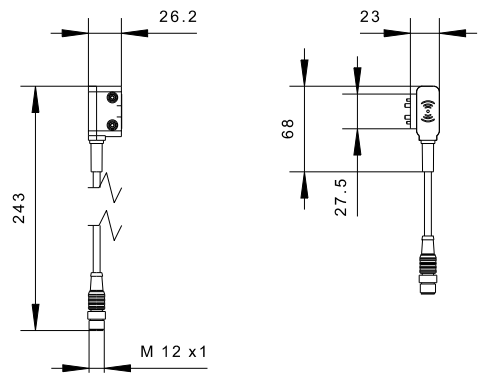

	MPS 015	MPS 025	MPS 035	
Order no.				
Description				
Connection				
Module order code				
R	K81579570	Safety+ module	M12 5-pole - cable length 0.2 m	S1M0

The Safety+ module can only be mounted on the robot side.



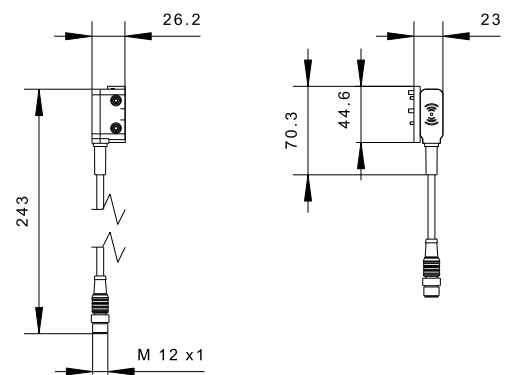

**MPS 055**

	Order no.	Description	Connection	Module order code
R	K81579620	Safety+ module	M12 5-pole - cable length 0.2 m	S1M1

The Safety+ module can only be mounted on the robot side.

## MPS 015/025/035/055 TRANSFER MODULES

# Safety+ valve unit

### Technical description

- integration by the customer into the robot controls or system controls needed
- decoupling the tool is only possible in the tool stand's safe detection area
- maintenance-free components
- enables safety requirements according to Performance level d, Category 3

## Safety+ valve unit

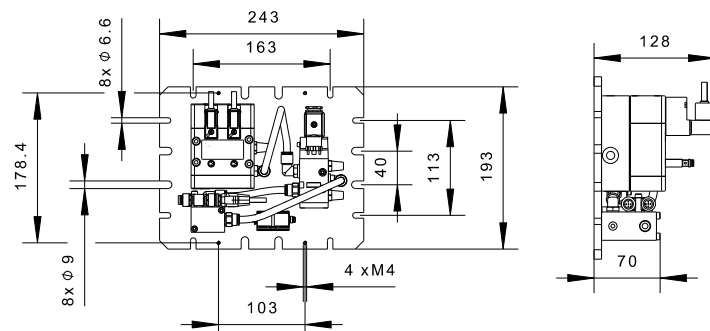

MPS 015

MPS 025

MPS 035

MPS 055

	Order no.	Description
R	K81569441	Safety+ valve unit

The Safety+ valve unit can be mounted on the robot arm or the floor.

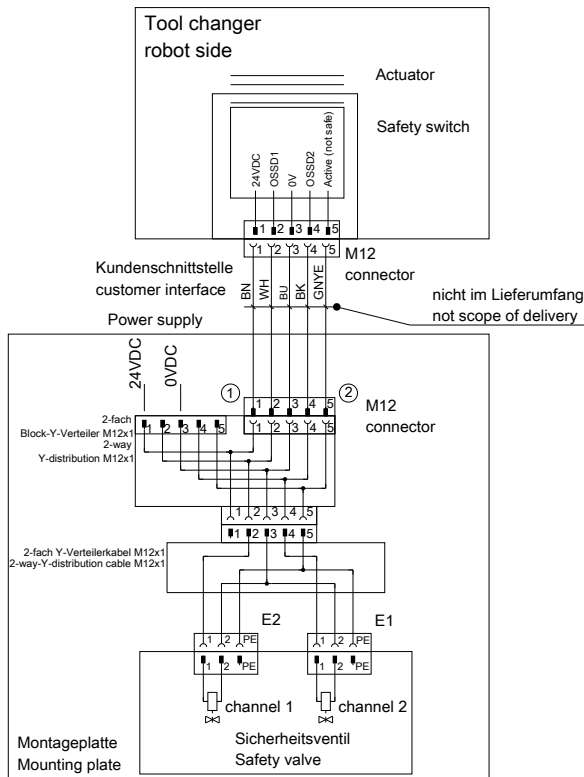

Wiring diagram for Safety+ valve unit

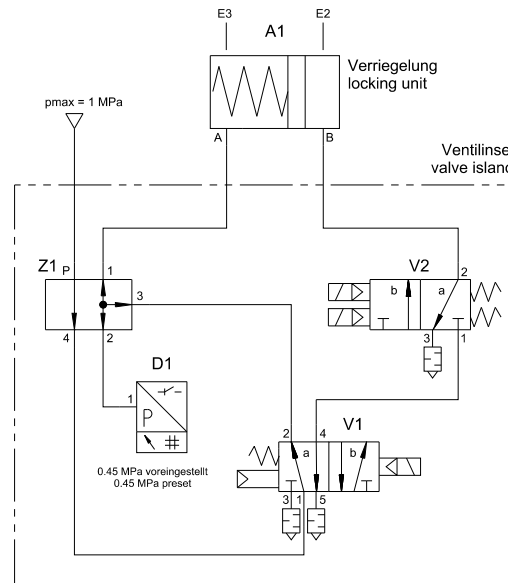

Pneumatic diagram for Safety+ valve unit

## Cover for Safety+ valve unit

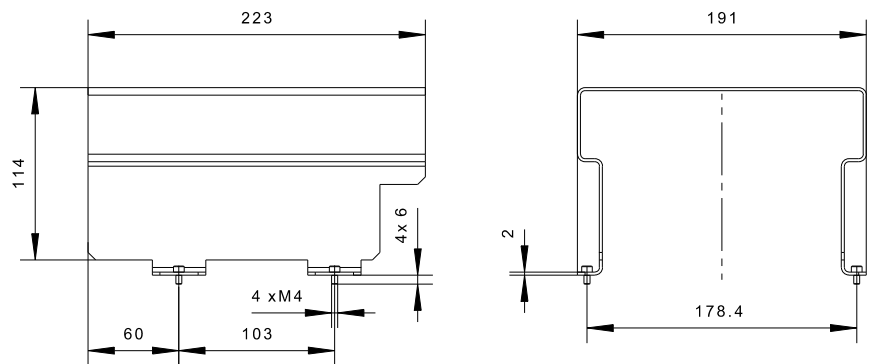

- MPS 015
- MPS 025
- MPS 035
- MPS 055

	Order no.	Description
R	K81579622	Cover for Safety+ valve unit

## MPS 015/025/035/055 ACCESSORIES

# MPS 015/025/035/055 Accessories

### Robot side mounting kit



Order no.	Product	Pitch diameter	Mounting materials	Strength class*	Locating pin
K81574214	MPS 015	Ø 31.5 mm	(4x) M5x30	12.9	(1x) 5/10
K81574215	MPS 025	Ø 40 mm	(4x) M6x30	12.9	(1x) 6/12
	MPS 035	Ø 50 mm			
K81574217	MPS 055	Ø 63 mm	(4x) M6x35	12.9	(1x) 6/12

\* The specifications of the robot manufacturers must be observed. If the specifications are different, use the appropriate strength class.

### Emergency release



Order no.	Description
K81558336	Tool for emergency release

### Teaching aid



Order no.	Product	Description
K81557990	MPS 015	Storage case including teaching aid and 2x centering sleeves for tool storage systems for easy teaching of the robotic tool changer.
K81557992	MPS 025	
K81557994	MPS 035	
K81557996	MPS 055	

Reorder centering sleeves (2x each required): Part no. K81775891 for MPS 015/025, part no. K81775890 for MPS 035/055.

## Robot adapter flange

ill.1

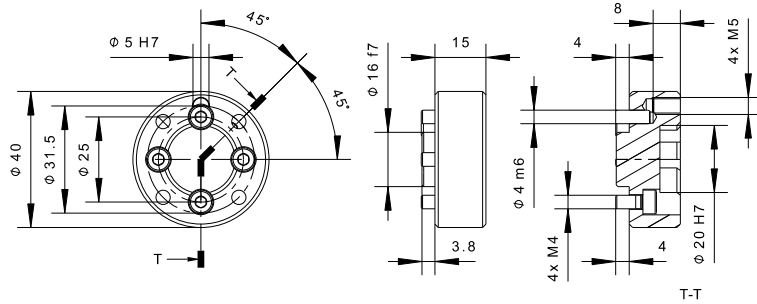

ill.2

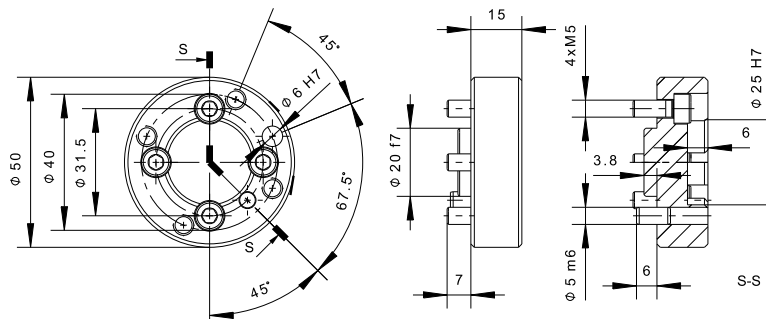

ill.3

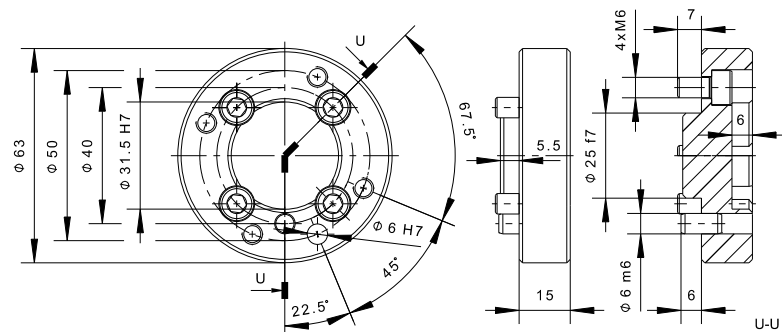

ill.4

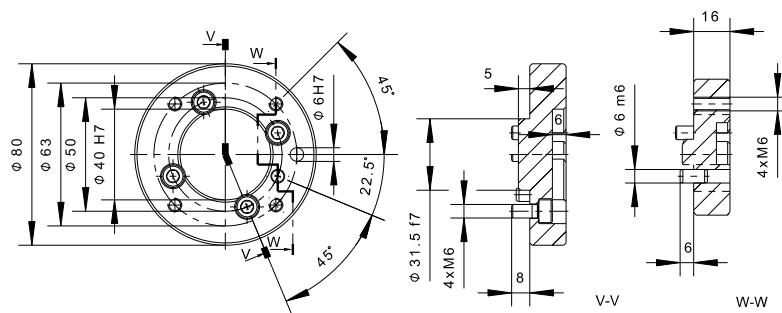

Order no.*	Adaption to	Fits	ill.
K81579636	ISO 9409-1-25-4-M5	MPS 015	1
K81579637	ISO 9409-1-31.5-4-M5	MPS 025	2
K81579638	ISO 9409-1-40-4-M6	MPS 035	3
K81579639	ISO 9409-1-50-4-M6	MPS 055	4

\* including mounting material.

## MPS CUSTOMIZED

# Customized designs



**Specialist know-how  
from construction to the finished solution**





**All components from a single source,  
perfectly coordinated**

**Our 125 years of passion for innovation and extensive expertise are reflected in our individual solutions for customers around the world. In close partnership, we develop tailor-made system designs, precisely and flexibly adapted to the respective requirements.**

As a developer of robotic tool changing systems, Stäubli has consistently implemented innovative, sustainable and variable technologies for decades. The modular MPS robot tool changer has an open product architecture that enables the customer-specific construction of perfectly coordinated systems.

Whether locking units for special payloads, transfer modules to be redesigned depending on the process or special solutions for tool storage systems: Stäubli implements specific requirements in optimally adapted, technologically mature system solutions.

- increase in transfer rates due to larger nominal sizes
- individual addition to the delivery programme for plug & play solutions
- special media resistance and robustness due to the use of highly resistant materials
- specifically designed electrical plug connections
- development of new transfer modules for specific manufacturing technologies

<b>MPS 080/130/260</b> Payloads up to 350 kg	<b>MPS 631</b> Payloads up to 630 kg	<b>MPS 1530/2531</b> Payloads up to 2500 kg
		

# Worldwide service presence and training competence



Face-to-face or online training, competence and experience available worldwide

**Stäubli has branches in all industrial centers around the world. Experienced engineers have detailed, product-specific know-how and application knowledge. This guarantees the highest quality of advice and fast response times - worldwide.**

Service and advice play a decisive role for the right basic and special configurations, adaptations and optimizations. We are your sole contact for the complete MPS system. Thanks to global warehousing, components and spare parts are always quickly on site. The transfer modules and connectors can be exchanged directly on the MPS system for simplified maintenance, without

the robot tool changer having to be removed or decoupled.

In addition, Stäubli offers training around the world on all topics relevant to MPS robot tool changing systems. Participants gain important knowledge for the commissioning, operation, maintenance and

servicing of the MPS robot tool changing systems.

With this knowledge, the productivity of the MPS robotic tool changing systems remains at a consistently high level. Trained staff is a prerequisite for the reliable and productive operation of your systems.



We would be happy to provide you with **3D data for our robot changers**. Contact us via our website and request your personal access for our download area:

[www.staubli.com](http://www.staubli.com)

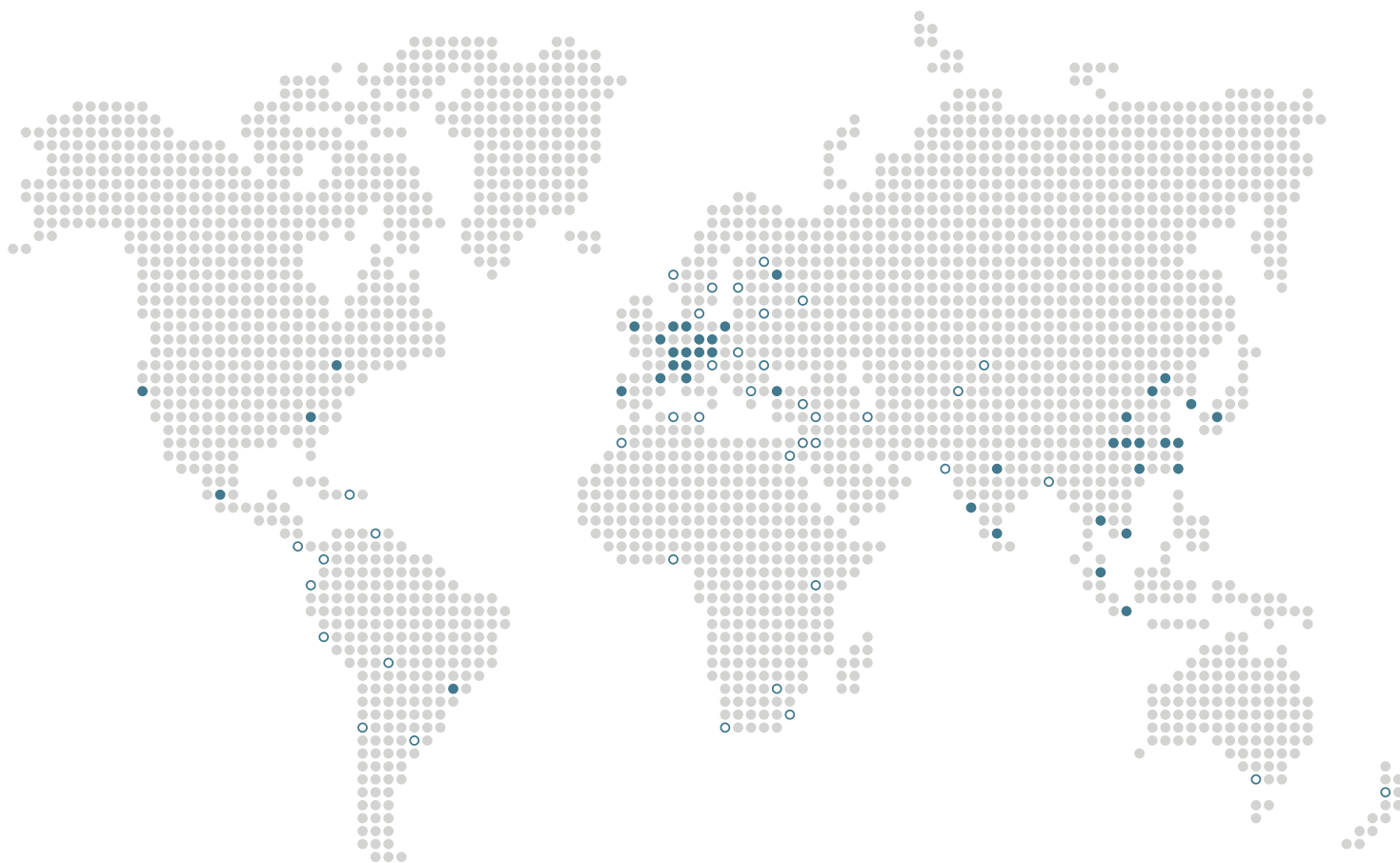

● Staubli Units    ○ Representatives/Agents

# Global presence of the Staubli Group

[www.staubli.com](http://www.staubli.com)