

MPS

Robotic tool changing systems for Payload up to 350 kg

Productivity for all industrial sectors



Table of contents

System structure	4	MPS 080	
		MPS 080 COMPLETE	20
Tool stand technology	5	MPS 080 MODULAR	26
		MPS 080 accessories	32
Quick change technology	6		
		MPS 130	
MPS solution competence	8	MPS 130 COMPLETE	34
Unique multifunctionality	8	MPS 130 MODULAR	40
Needs-oriented modularity	9	MPS 130 accessories	46
Powerful base unit - high precision locking	10	MPS 080/130 tool stand	48
Trouble-free connections	11		
One system for all robots	12	MPS 260	
Certified safety technology	13	MPS 260 COMPLETE	56
Millions of docking cycles with minimum wear	14	MPS 260 MODULAR	66
IDA bus module	15	MPS 260 accessories	74
Stäubli's global competence and local presence	16	MPS 260 tool stand	76
100 % Stäubli performance	17		
From robot performance data to system selection	18	MPS 080/130/260 transfer modules	84
		Transfer modules for fluids and pneumatics	86
Payload overview	19	Transfer modules for pneumatics	87
		Transfer modules for pneumatics and vacuum	88
		Transfer modules for shielding and earth connection	90
		Transfer modules for welding power transmission	91
		Integrated bus module IDA for condition monitoring	92
		Electrical modules for signal and servo power transmission	96
		Active Docking safety modules	104
		MPS CUSTOMIZED	106
		Wiring diagrams	108

R Base unit
robot side

 **Process safety**
maximum process safety for
equipment and personnel

 **Economic efficiency**
for cost-effective and sustainable
production processes

T Base unit
tool side

 **Flexibility**
for maximum function diversity in
robotic manufacturing processes

 **Productivity**
for innovative and quality-
optimised production processes

THREE SOLUTIONS

Our systems are just as flexible as your processes

Stäubli robotic tool changing systems are designed according to a modular product concept that guarantees variable multi-functionality and optimum integration into all industrial robot manufacturing processes.

Payload-specific base units on the robot and tool side are the basis for the three Stäubli tool changing system solutions.

MPS COMPLETE

Ready-to-use application solutions

Our preconfigured complete solutions provide you with ready-to-use robotic tool changing systems:

- The transfer modules are selected on the basis of the most frequently configured robotic tool changing systems.
- The products in this range can be delivered with very short lead times.
- Additional transfer modules can be added at any time.
- Internationally standardised interfaces ensure the simple connection of the robot dress packs.

MPS MODULAR

Individually configurable solutions

Our individually configurable solutions offer you the full benefits of our modular system by allowing you to configure a robotic tool changer to your specific application:

- You make your selection from our large portfolio of transfer modules and we deliver the fully assembled tool changer to you.
- A simple configuration tool guides you through the entire ordering process.
- The transfer modules can be positioned for easy connection of the dress pack.
- You can reposition the transfer modules and adapt them to new production technologies if required.

MPS CUSTOMIZED

Customized designs

We produce customized tool changing systems for complex applications requiring special base units or extra equipment:

- The basic units on the robot and tool side, as well as the transfer and safety modules, are adapted to the applications.
- You get a system that is perfectly tailored to all your performance data, material quality and connection requirements.
- Individual tool stands enable the optimum integration of the system into your robot line.

SYSTEM STRUCTURE

A flexible concept for every robot

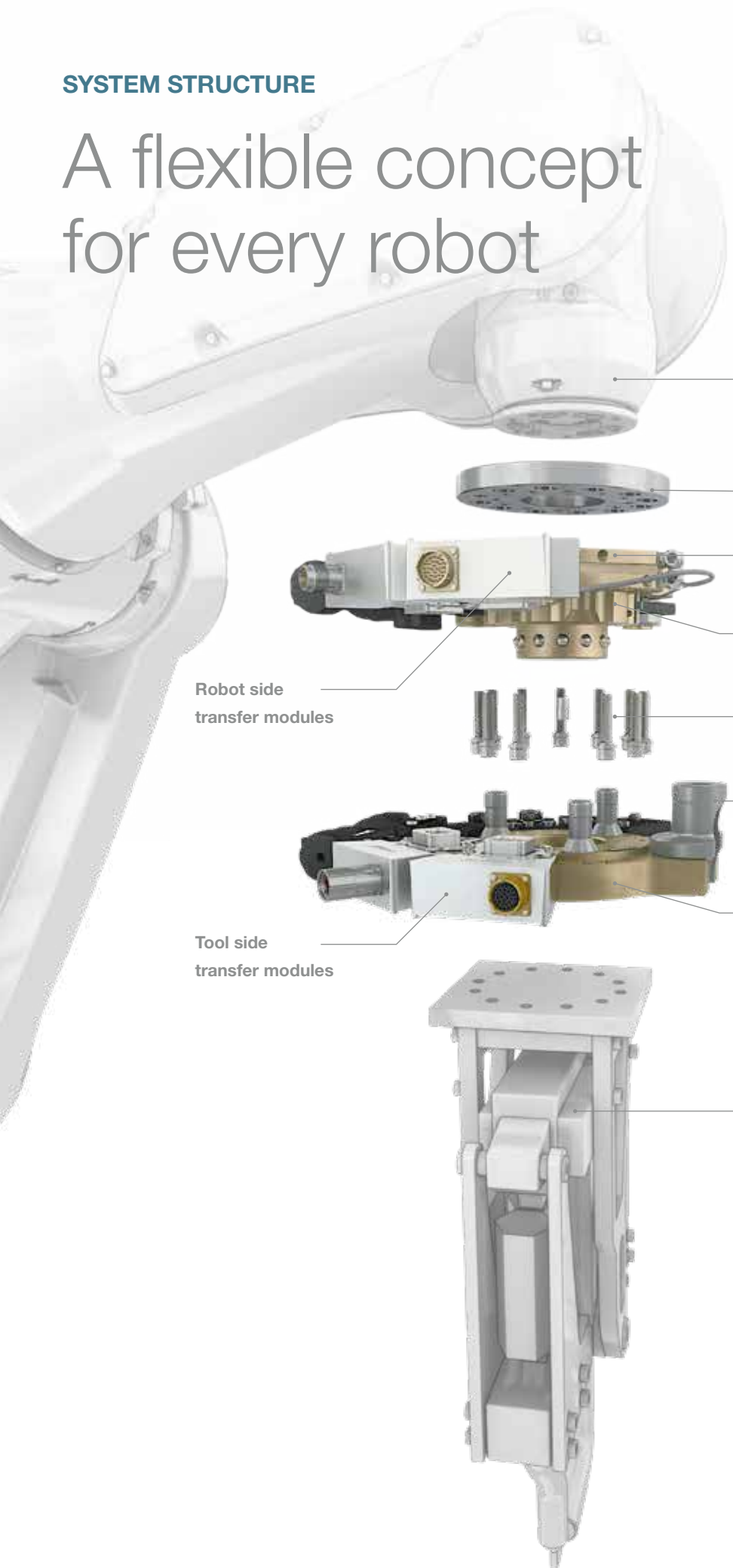

Robot

Mounting on the flange suitable for all makes of robot

Robot adapter flange*

R Base unit robot side

Sensors

Mounting kit robot side

Tool side docking hook

T Base unit tool side

Tool

Signal, media and power supply of the tool through transmission modules

* Including mounting materials.

TOOL STAND TECHNOLOGY

Optimal system integration for maximum efficiency

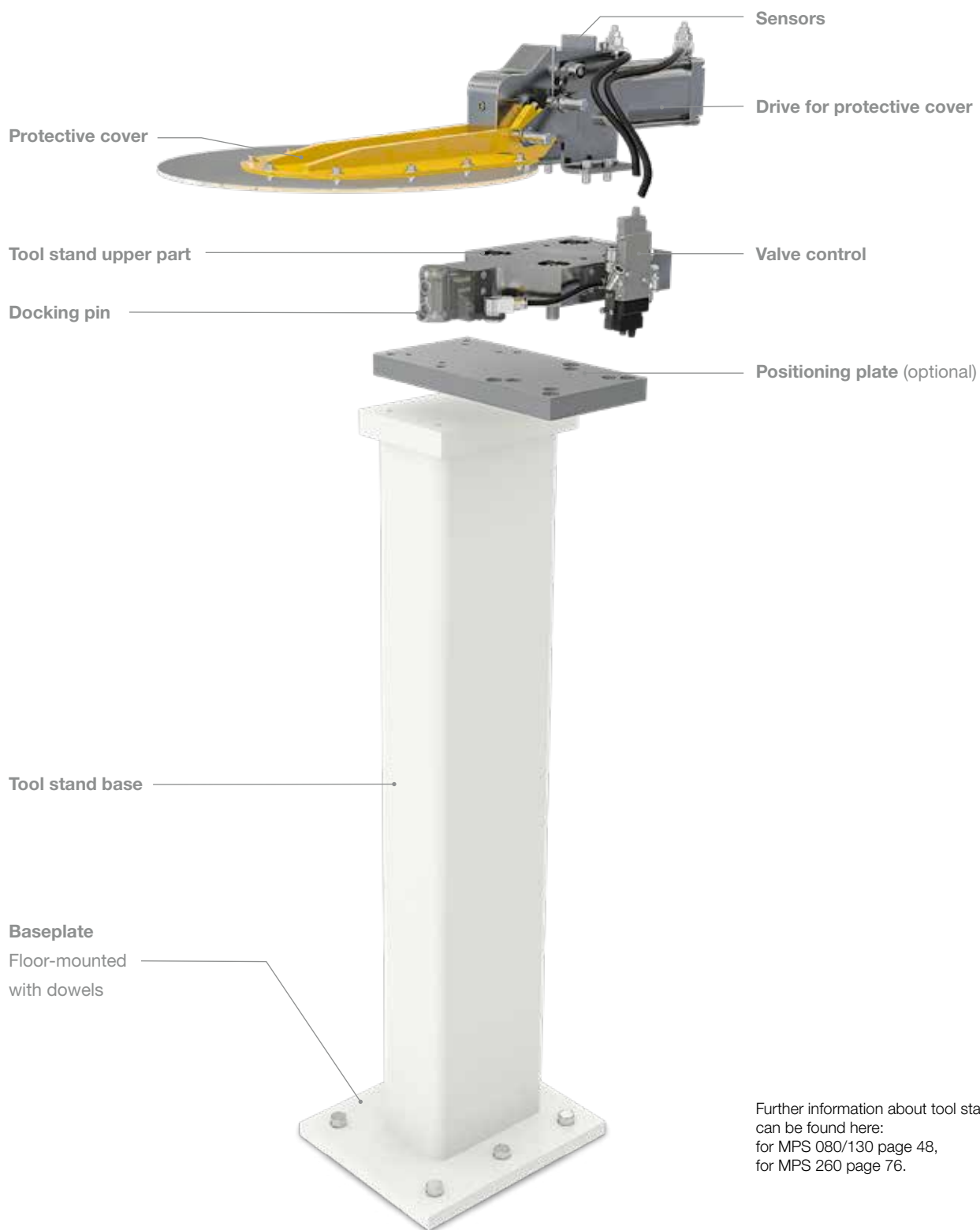

Further information about tool stand technology can be found here:
for MPS 080/130 page 48,
for MPS 260 page 76.

QUICK CHANGE TECHNOLOGY

Tool changing system – robot and tool side

R Base unit
robot side

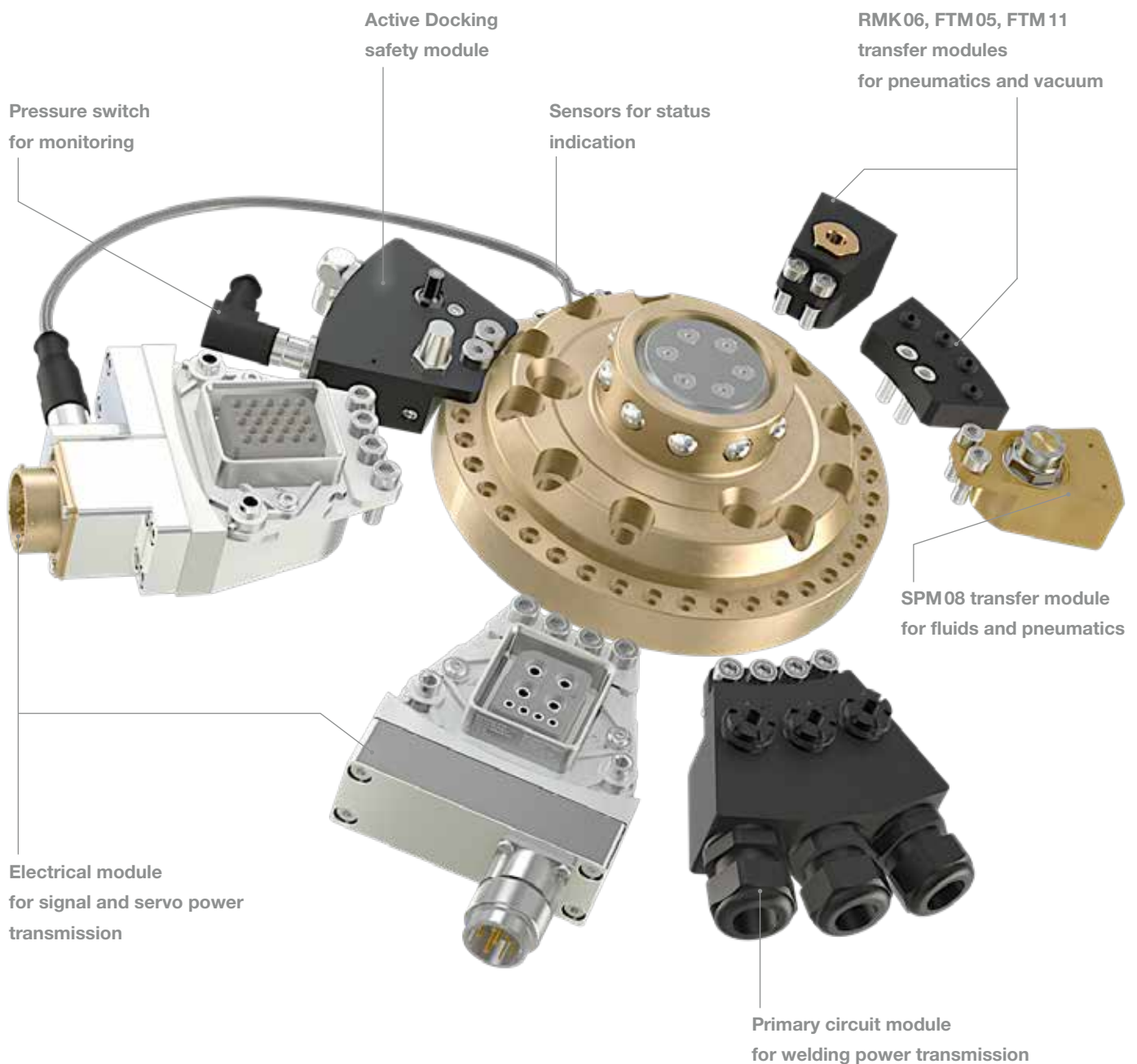

T Base unit
tool side

RMK06, FTM05, FTM 11
transfer modules
for pneumatics and vacuum

Docking hook

Active Docking
safety module

SPM08 transfer module
for fluids and pneumatics

Primary circuit module
for welding power transmission

Electrical module
for signal and servo power
transmission

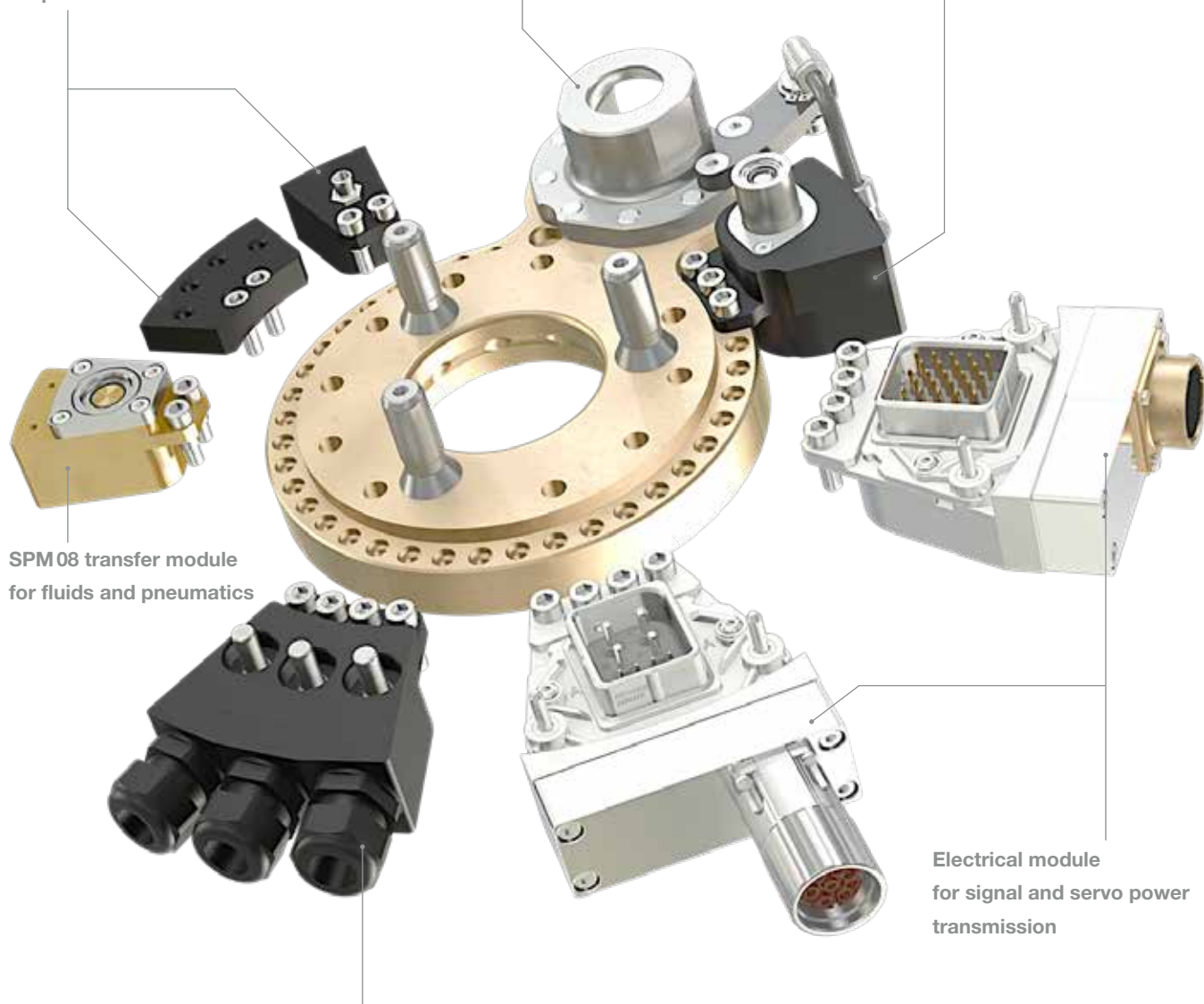

Multi-functionality – for diverse technology

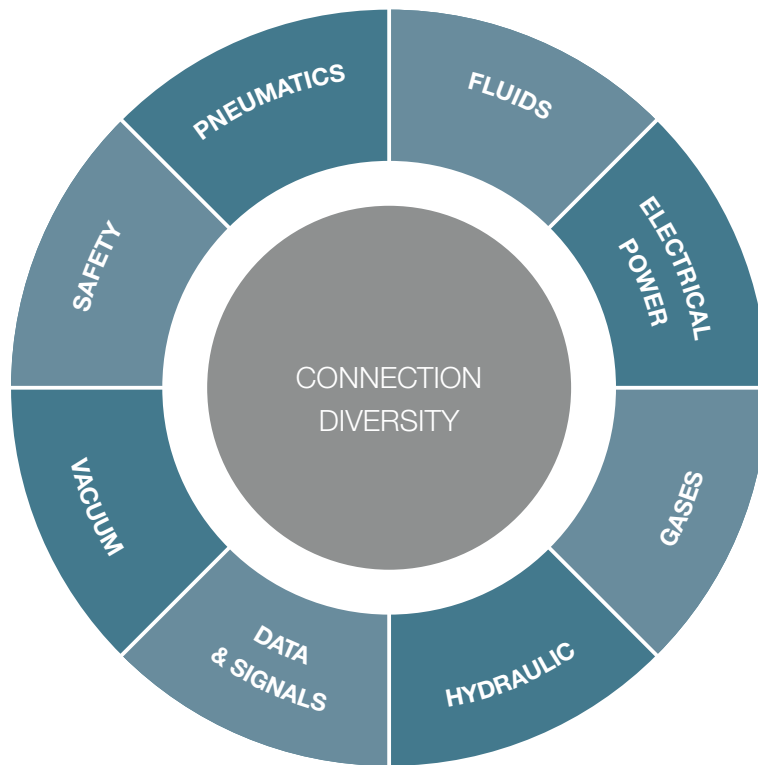

Stäubli MPS systems can be equipped with a wide range of transfer modules for different applications. This multi-functional design maximises production efficiency covering the entire spectrum of industrial robot applications. The Stäubli MPS systems incorporate more than 60 years of expertise in coupling technology for electrical and fluid media exploiting the full potential of robotic production technology.

The basic units on the robot and tool side are circular in design maximising flexibility when equipping the tool changer system with a variety of transfer modules.



Flexibility

Robot versatility is guaranteed because of the diverse modules. Energy and data transfer can be added to the robotic tool changing systems at any time. As a pioneer in coupling technology with decades of experience, Stäubli can also design individual coupling and connection solutions for specific requirements.



Productivity

Stäubli robotic tool changers provide flexible technology and productivity in a wide range of applications: from simple handling applications to various welding methods, punch riveting, screwing, gluing and material transfer.

Modularity orientated to need

The MPS systems are based on a modular concept that provides the ideal platform for a flexible and versatile system. For all robotic applications there are suitable transfer modules available – developed by Stäubli and easily integrated into the changers.

On the robot side, the tool changers are already equipped with the maximum configuration of transfer modules for the robot's applications. The tool side is only equipped with the transfer modules that are required for the respective tool.



Flexibility

The modular design makes it possible to adapt the system at any time. This allows you to make unlimited changes to your robot manufacturing processes. The robotic tool changer's function can be adapted to changing requirements and new technologies.



Economic efficiency

The MPS tool side base unit is only populated with the transfer modules that are necessary for the respective tool, reducing the investment to a minimum.

Gripping/ welding



Gripping

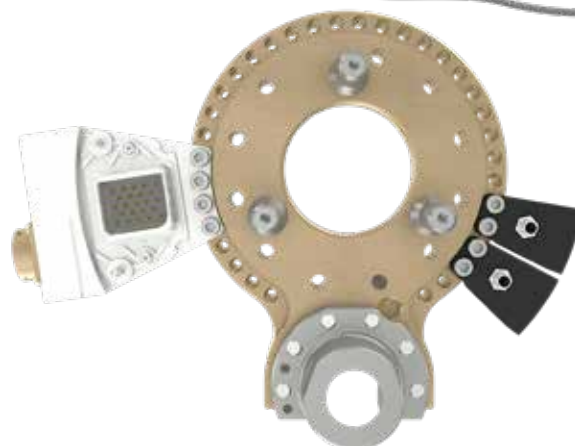

Welding



Powerful base unit – high precision locking

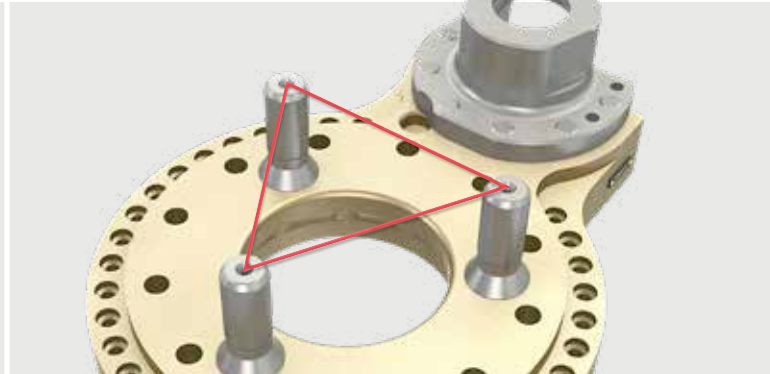
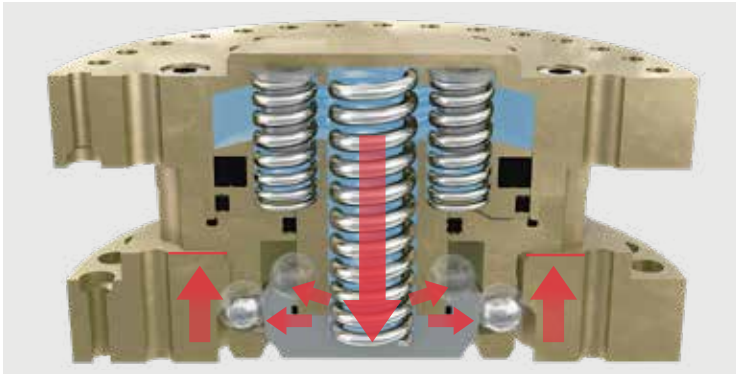

**Powerful and precise locking for
safe and error-free processes**

Stäubli tool changing systems ensure high-precision connection between the robot and the tool. The intelligent design of the robotic tool changer ensures absolute precision and a long service life.

The robot and tool side are pre-aligned and brought together via three guide columns. The conical locking surfaces ensure exact positioning between the two sides of the MPS tool changing system. A large volume of high-strength locking balls maintain the friction lock between robot and tool.



Process safety

You benefit from the precise repeatability of the changer system ($\pm 0,01$ mm for each axis). Even following a high number of change cycles, the tools are brought to their exact operating position, and placed precisely on the tool stand. Designed for horizontal or vertical use, the tool stand, with optional tool support, is an integral part of the system.



Economic efficiency

Due to the high-precision locking even extremely bulky tools can be precisely positioned as defined by the manufacturing process, guaranteeing consistent product quality.



Productivity

The lock is designed for an extremely high number of change cycles. This guarantees permanent precision and maximises production output.

Smart details – for perfect connections

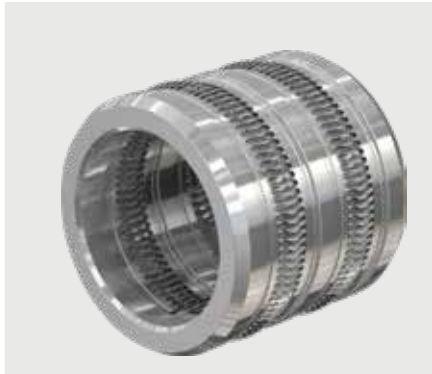

Coupling technology that guarantees maximum power transmission

As the global market leader in high-quality coupling technology, Stäubli has been developing and designing connection solutions for media, data and energy transmission for decades. In industrial applications these solutions have proven to be reliable over time with low levels of wear and tear, even when operated under tough conditions.

Stäubli designs durable and robust transfer modules for robotic tool changing systems reaching the highest quality levels. As a result of their highly efficient and intelligent design concepts, both the media couplings and the electrical

plug connections guarantee 100% power transmission. MULTILAM technology minimises contact resistance and maximises contact integrity in electrical signal transmission – even with high current.

The sophisticated valve technology of the liquid and gas transfer modules ensures high flow rates and prevents contamination on the production line due to leakage.



Process safety

A constant, maximum media and energy transfer is guaranteed in the long term.



Economic efficiency

The Stäubli transfer modules are designed for an extremely high number of mating cycles and therefore have a very long service life.

One system for all robots

Stäubli's competence in all aspects of robotic tool changing systems draws on its decades of experience as a robot and coupling manufacturer. Based on its in-depth technical know-how of the industrial requirements of robotic production lines, it has developed versatile tool changer solutions that are suitable for robots supplied from any manufacturer.

The MPS systems developed by Stäubli can be installed on any robotic arm anywhere in the world, whatever its type, make or year of production. The changer mounting flanges are based on ISO-standard drilling patterns, but can easily be adapted to other robot flange patterns. The height of the tool changing system in the coupled state is restricted to the minimum so that its full load bearing capacity can be exploited.

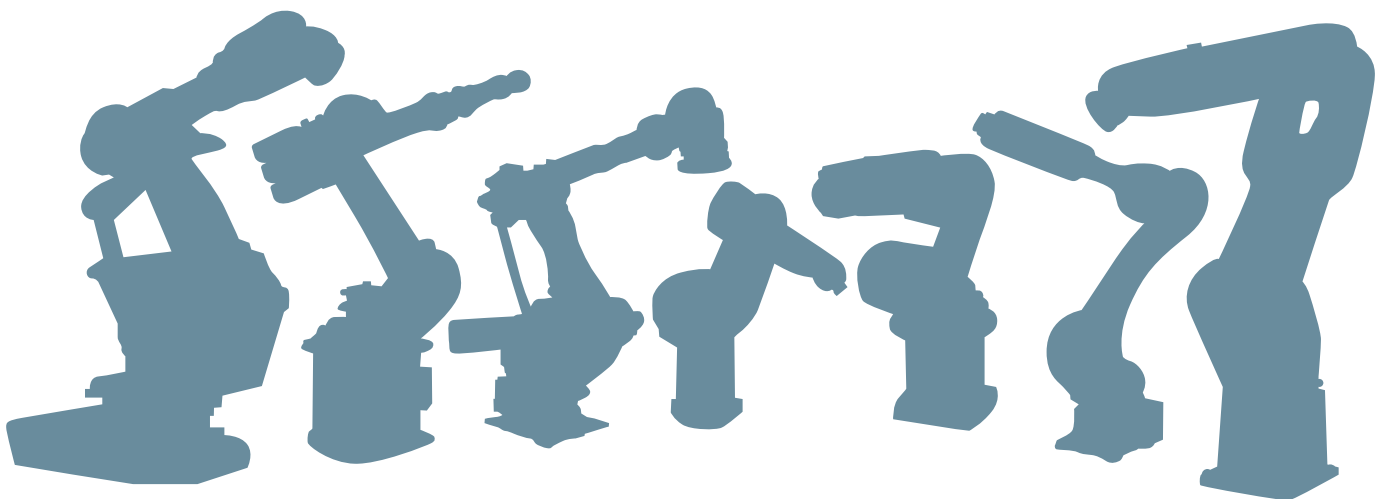

Certified safety technology for people and facilities

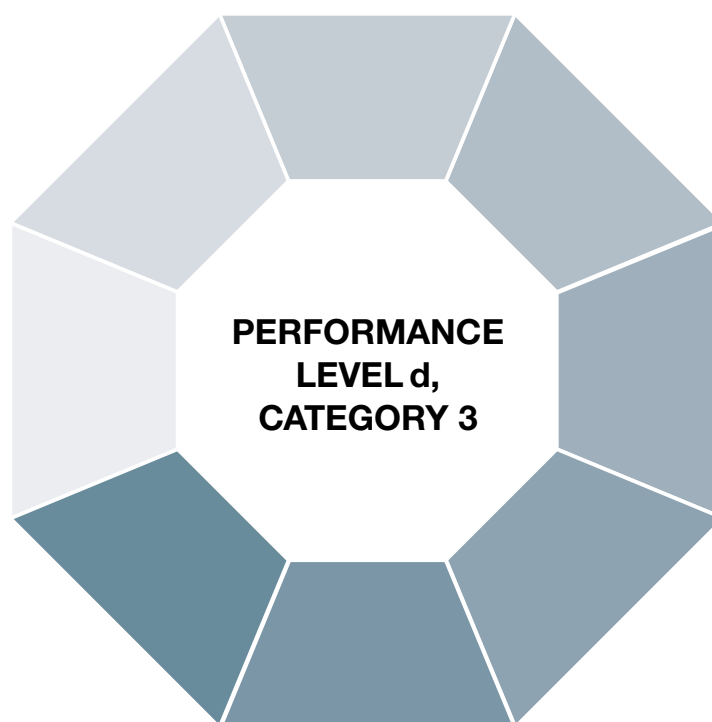

Personnel and plant safety is essential in automated processes. Manufacturers and operators of robots and robotic devices have to ensure compliance with the ISO 10218-2 standard. Stäubli robotic tool changers satisfy the demanding requirements of “Performance Level d, Category 3”. The safety concept for the Stäubli MPS systems provides reliable protection for operators and safeguards process quality.

This MPS system safety level can either be achieved by electromechanical transponder technology or with the Active Docking System developed by Stäubli.

Both are integral aspects of the product concept. The **transponder option** consists of a safety switch in combination with the Stäubli ISB 200 logic module acting as a bus system-independent safety circuit.

The **Active Docking System** is a proprietary development by Stäubli. The compressed air supply for the decoupling process is provided as an individual circuit that is only available in the tool stand. This means that the tool can only be unlocked at the tool stand. Once the robot has picked up a tool it cannot be accidentally unlocked because there is no connection to the compressed air supply.



Process safety

Maximum safety of robot systems operators and automated tool change processes are guaranteed.

Millions of docking cycles – with minimum wear



All the media couplings and electrical connectors integrated in the modules feature floating contact technology. This reduces wear to a minimum, ensuring a precise and reliable connection even after millions of docking cycles. For maintenance purposes, parts can be replaced quickly with minimal interruption to the robot workflow.

Transfer modules and connectors can be replaced directly on the MPS system without the need to disassemble the tool changer, or to disconnect cables and hoses. This allows entire modules to be replaced quickly and easily. A cartridge system (Quick Change Inserts) makes it possible to replace worn parts directly in the modules.



Process safety

Floating contact technology allows the plug and socket for fluid connectors and the pins and socket for electrical connectors to align. This ensures perfect connection of both fluid and electrical connections.



Economic efficiency

The long life of Stäubli components guarantees a reliable coupling processes even after millions of docking cycles. Long maintenance intervals reduce downtime, as well as repair and replacement part costs.



Productivity

The service-friendly design of the transfer modules, as well as the integrated media couplings and electrical connectors, ensure maintenance time is minimal.

Simple integration – the IDA bus module



Control, monitor, report: The newly developed, integrated IDA bus module is able to communicate with each tool changing process via the individual sensors and actuators located within the tool. The system communicates with the higher-level control unit via a standard ProfiNet, Ethernet IP and Modbus protocols.

The integrated IDA bus module connects all the safety-relevant monitoring and diagnostic functions. This module also provides shielding, earthing and an automatic power shut off for the actuators during the coupling process.



Productivity

The IDA bus module, which functions as a central interface, can be quickly and easily installed on the base unit. It requires one module slot on the changing system base unit and links all the sensors via a central plug connection. Only the bus cable, power supply and the operational grounding are connected to the robot. Our easy-to-use web application is available for software configuration.



Process safety

With its extremely small mounting radius, the integrated IDA bus module has a minimal interference profile. Combining the interface functions in to a single component reduces the number of cable connections to the minimum. As a result, the entire tool changer system is significantly smaller, which minimises the risk of collision and allows the robot's hand to move in places that would otherwise be difficult to access. The robust IDA housing is constructed from metal, which ensures that the heat generated by the electronic components is optimally conducted away from the module. This tool changing system is designed to withstand harsh ambient conditions, of up to IP65.

Stäubli's global competence and local presence



Stäubli has subsidiaries at major industrial hubs around the world. Their experienced engineers have detailed, product-specific know-how and application expertise to provide the highest quality of advice to customers and to guarantee fast response times worldwide.

Robotic tool changers are variable systems that have to be efficiently integrated into production processes, therefore advice to customers on the correct basic and special configurations, adaptations and optimisations is essential. Our global warehousing concept ensures that components and spare parts are quickly delivered to customers around the world.



Flexibility

Users receive solutions that comply with all country-specific guidelines and standards. The robotic tool changing systems are adapted to national industrial norms, such as thread standards or information retrieval technologies in sensor systems. Thanks to our global network customers can easily implement multi-national production concepts.



Productivity

Wherever in the world, users receive specialist advice on applications. This guarantees the best possible implementation of the tool changing processes on robot lines at any production site. Customers have access to our global

know-how so that you can maximise the productivity of new plants and achieve optimum results in retrofit and maintenance situations.



Economic efficiency

Single point of contact: we designate one customer consultant to you for the entire duration of your project. This makes the cooperation more efficient and reduces the complexity of project coordination and implementation. Customers also benefit from our consulting expertise directly at your premises when you implement tool changing systems.

100 % Stäubli performance

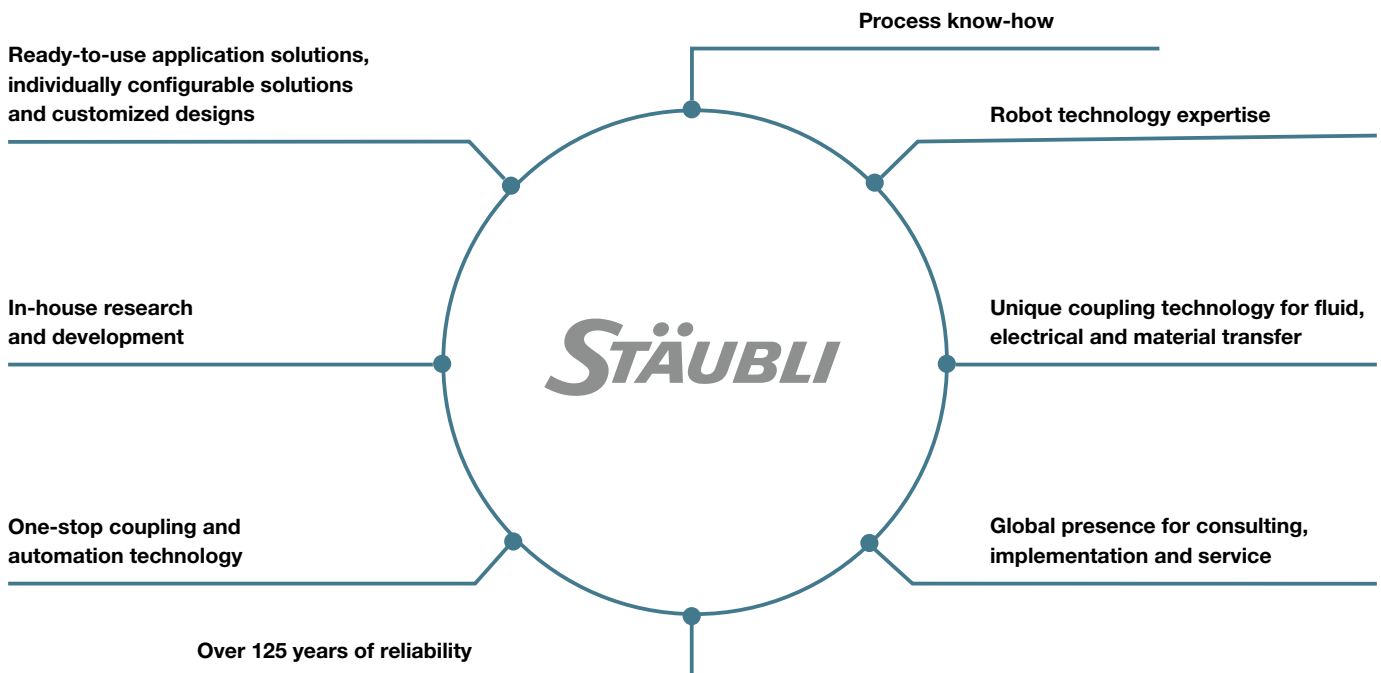

All the components of the Stäubli MPS systems come from a single source and are perfectly harmonised. Stäubli performance is 100% based on a combination of products, expertise and know-how.

All individual components – from base unit to transfer module – are developed and manufactured by Stäubli. As your single contact we are responsible for the entire MPS system. Our customers can count on us supporting them with our expertise and experience.



Process safety

You have the assurance of integrating well-engineered and comprehensively tested robotic tool changers into your production line. All systems and components are designed and manufactured by Stäubli to the highest industrial standards, supporting you with our process analysis and optimisation know-how.



Flexibility

Stäubli's robotic tool changing systems are designed for application-specific module and component configuration. The product concept makes complete ready-to-use systems (MPS COMPLETE), individually configurable systems (MPS MODULAR) and customized designs (MPS CUSTOMIZED) possible.



Economic efficiency

With over 60 years of experience as a global manufacturer in coupling technology for media and power connections, Stäubli delivers unprecedented performance and longevity. Component compatibility is guaranteed – ensuring risk free investment.

From robot performance data to system selection

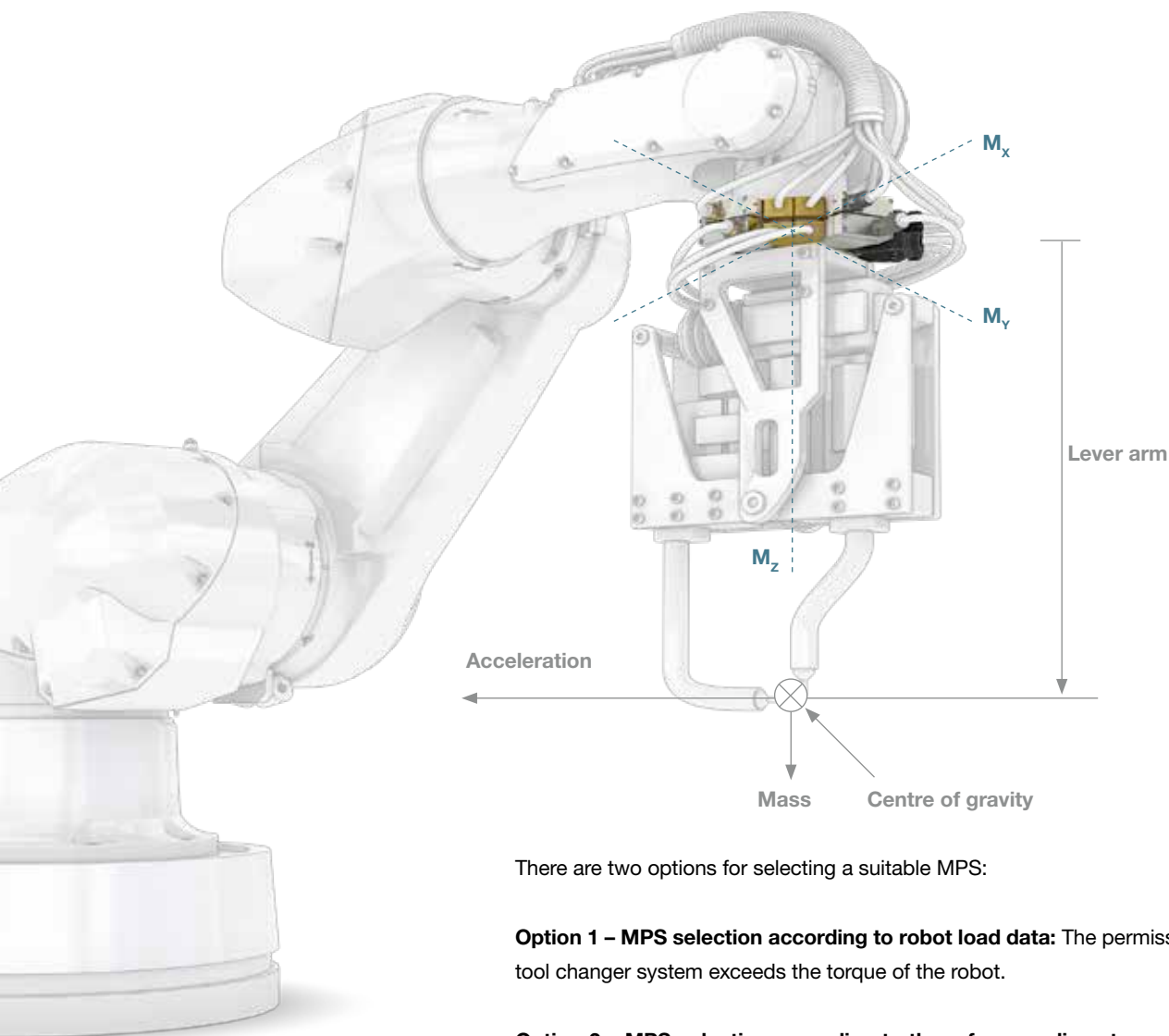

There are two options for selecting a suitable MPS:

Option 1 – MPS selection according to robot load data: The permissible torques of the tool changer system exceeds the torque of the robot.

Option 2 – MPS selection according to the reference diameter and/or payload: The application must be calculated using the formula $\text{Torque} = \text{Mass} \times \text{Lever arm} \times \text{Acceleration}$. The max. torques of the tool changer system must not be exceeded under any circumstance. If the max. torque of the MPS needs to be exceeded, the Mass, Lever arm or Acceleration parameter must be adjusted.



Provide us with the robots make, model and year of manufacture and we will be happy to advise you on individual payload determination! Contact us at:



www.staubli.com

PAYLOAD OVERVIEW



	MPS 080		MPS 130		MPS 260		MPS 260S	
	M_x / M_y	M_z	M_x / M_y	M_z	M_x / M_y	M_z	M_x / M_y	M_z
max. static moment*	286 Nm	286 Nm	800 Nm	900 Nm	2000 Nm	2000 Nm	2500 Nm	2500 Nm
max. dynamic moment*	1001 Nm	1001 Nm	2800 Nm	3150 Nm	7000 Nm	7000 Nm	8750 Nm	8750 Nm
max. payload	80 kg		100 kg		350 kg			
max. repulsion force	14 kN		16 kN		25 kN			
max. connection force	14 kN		16 kN		25 kN			
max. lateral force	10 kN		10 kN		18 kN			
Pitch circle diameter (PCD) robot adapter flange	ISO 9409-1-80-6-M8		ISO 9409-1-100-6-M8		ISO 9409-1-125-11-M10			
Height (coupled)	67 mm		67 mm		67 mm			
Weight - robot side	2 kg		1.8 kg		3.8 kg			
Weight - tool side (included adapter)	1.2 kg		1.1 kg		2.2 kg		2.5 kg	
Compressed air connection	Push-lock hose-Ø 6 mm		Push-lock hose-Ø 6 mm		Push-lock hose-Ø 6 mm			
Operating pressure	0.45 - 1 MPa 0.31 NI/ cycle at 0.6 MPa		0.45 - 0.8 MPa 0.8 NI/ cycle at 0.6 MPa		0.5 - 1.0 MPa 1 NI/ cycle at 0.6 MPa			
Repeatability	+/- 0.01 mm		+/- 0.01 mm		+/- 0.01 mm			
Query	locked/ unlocked/ coupled		locked/ unlocked/ coupled		locked/ unlocked/ coupled			
Emergency release	yes		yes		yes			
Safety in case of drive medium failure	yes, by compression spring		yes, by compression spring		yes, by compression spring			
Number of module spaces	5 to 10		6 to 12		7 to 14			

* Due to their potentially high acceleration, robots can generate dynamic moments that are several times higher than static moments. The dynamic moments can occur in an emergency stop situation of the robot. Since they occur only very rarely during the robot's lifetime a static proof of strength is usually sufficient for this purpose.

MPS 080 COMPLETE

MPS 080/1

For handling and gripping applications

R



T



Application	Sensors		Connection transfer modules*		Order no.
			Pneumatic	Signal	
Gripping/ handling	R	PNP	1x G 1/8	KPTC2E18-32P	MPS080RC-0000-0000-0000-00WB-ECAB
	R	NPN			MPS080RG-0000-0000-0000-00WB-ECAB
	T	-			KPTC2E18-32S

Technical data for the base unit on the robot and tool sides can be found on page 28.
 * Technical data for all transfer modules can be found from page 84 onwards.



Transfer modules with alternative thread and plug connections can be customized using our simple configuration system (see page 26).

R

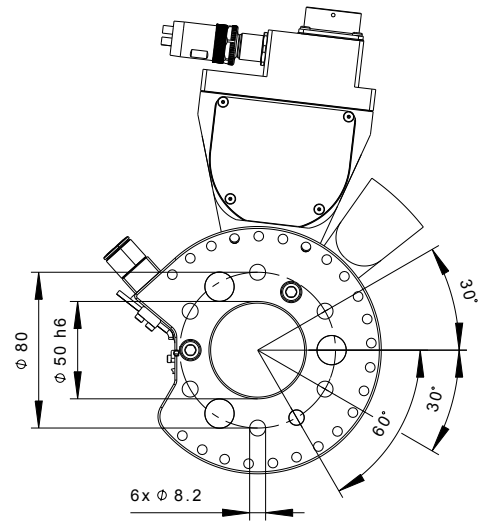
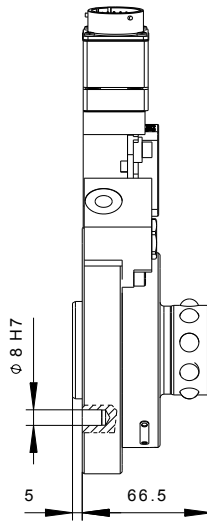
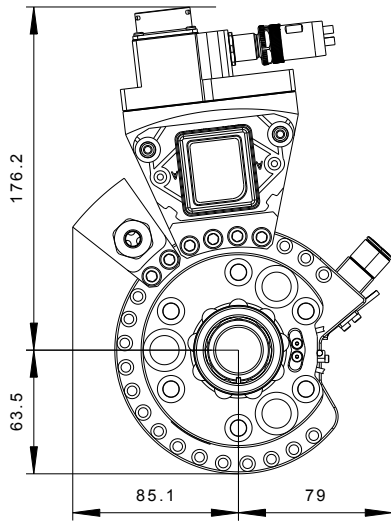

T

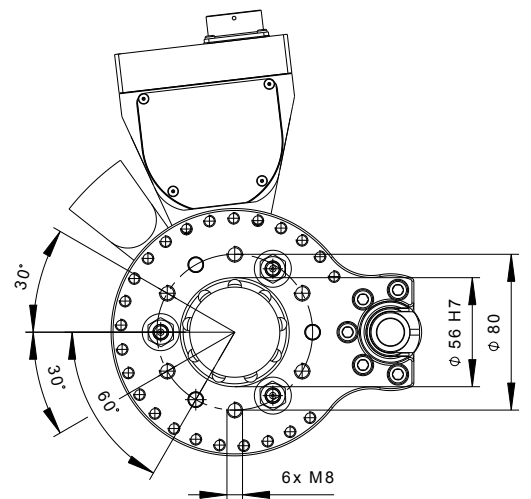
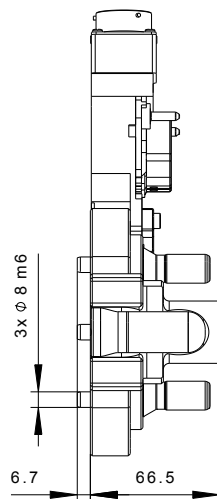
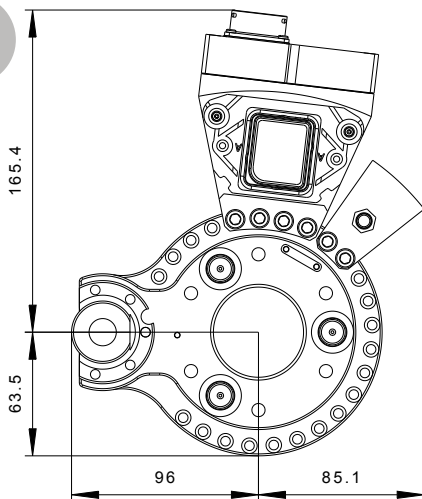

MPS 080 COMPLETE

MPS 080/2

For handling, gripping and vacuum applications

R



T



Application	Sensors	Connection transfer modules*		Order no.
		Pneumatic	Signal	
Gripping/ handling/ vacuum	R PNP	4x G 1/8	KPTC2E18-32P	MPS080RC-0000-0000-0000-P4WP-ECAB
	R NPN			MPS080RG-0000-0000-0000-P4WP-ECAB
	T -		KPTC2E18-32S	MPS080TA-0000-0000-0000-P4WP-ECAB

Technical data for the base unit on the robot and tool sides can be found on page 28.

* Technical data for all transfer modules can be found from page 84 onwards.



Transfer modules with alternative thread and plug connections can be customized using our simple **configuration system** (see page 26).

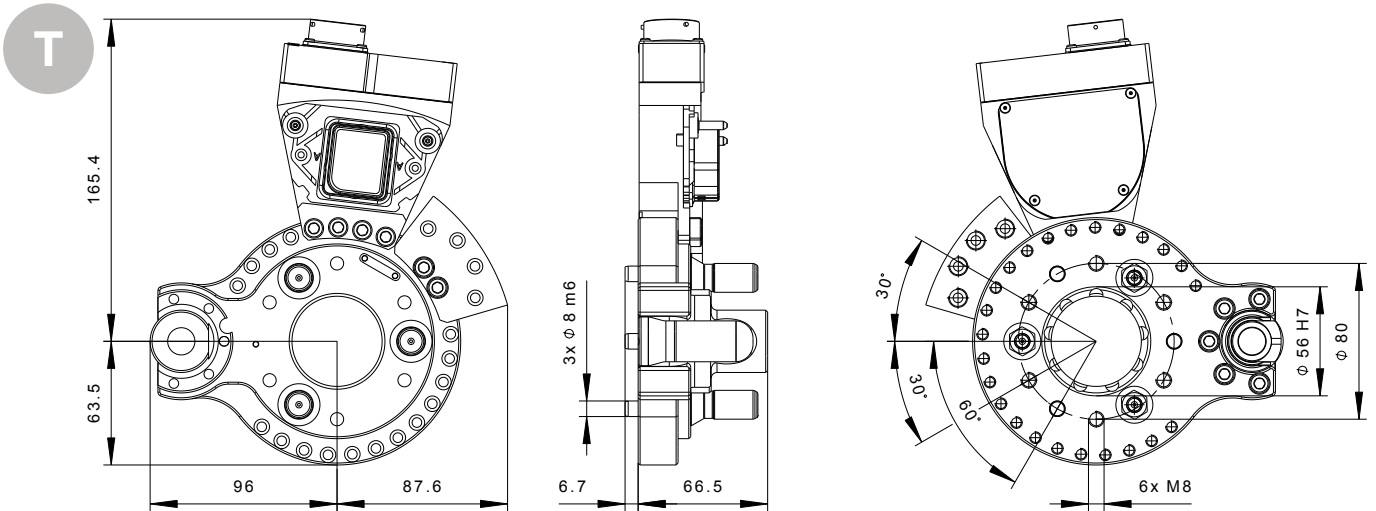
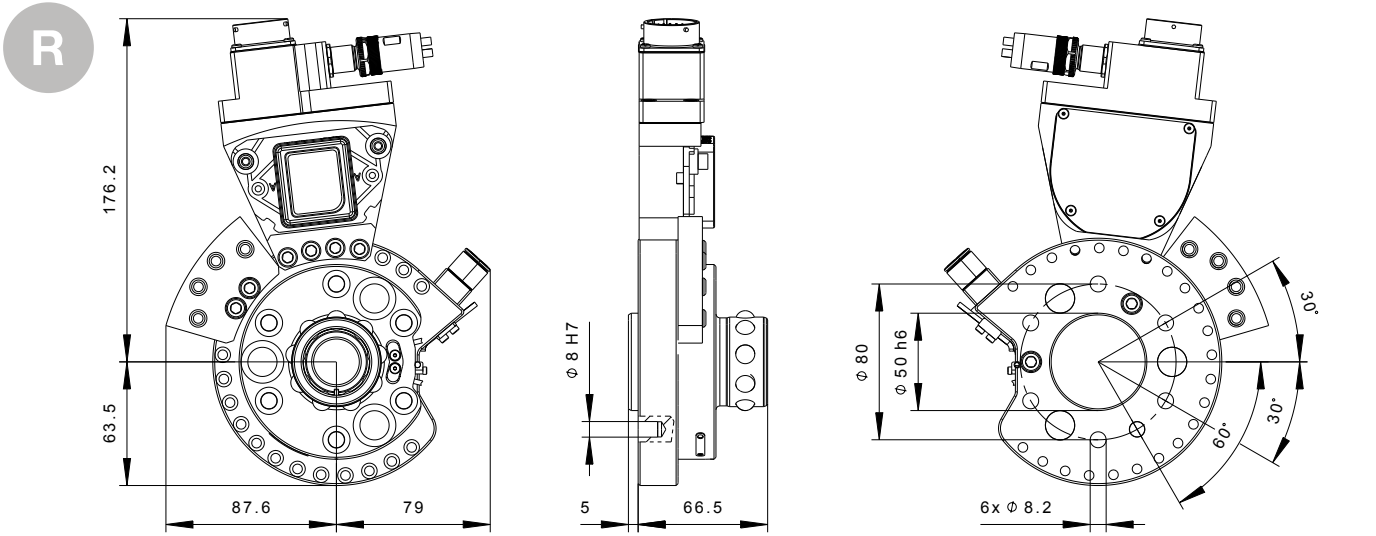

MPS 080 COMPLETE

MPS 080/3

For handling, gripping and vacuum applications

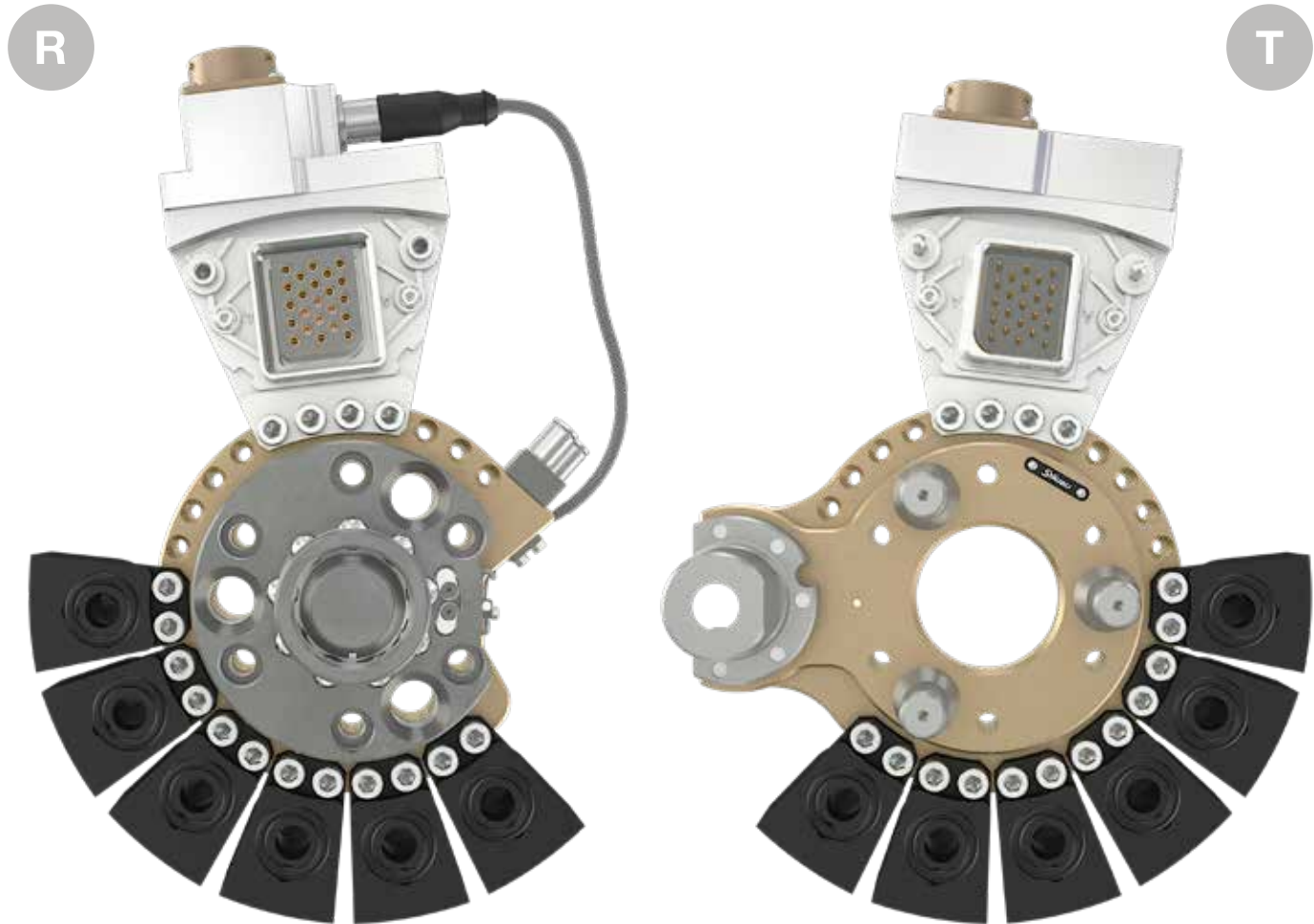

Application	Sensors		Connection transfer modules*		Order no.
			Pneumatic	Signal	
Gripping/ handling/ vacuum	R	PNP	6 x G 3/8	KPTC2E18-32P	MPS080RC-WEWE-WEWE-WEWE-0000-ECAB
	R	NPN			MPS080RG-WEWE-WEWE-WEWE-0000-ECAB
	T	-		KPTC2E18-32S	MPS080TA-WEWE-WEWE-WEWE-0000-ECAB

Technical data for the base unit on the robot and tool sides can be found on page 28.
 * Technical data for all transfer modules can be found from page 84 onwards.

 Transfer modules with alternative thread and plug connections can be customized using our simple configuration system (see page 26).

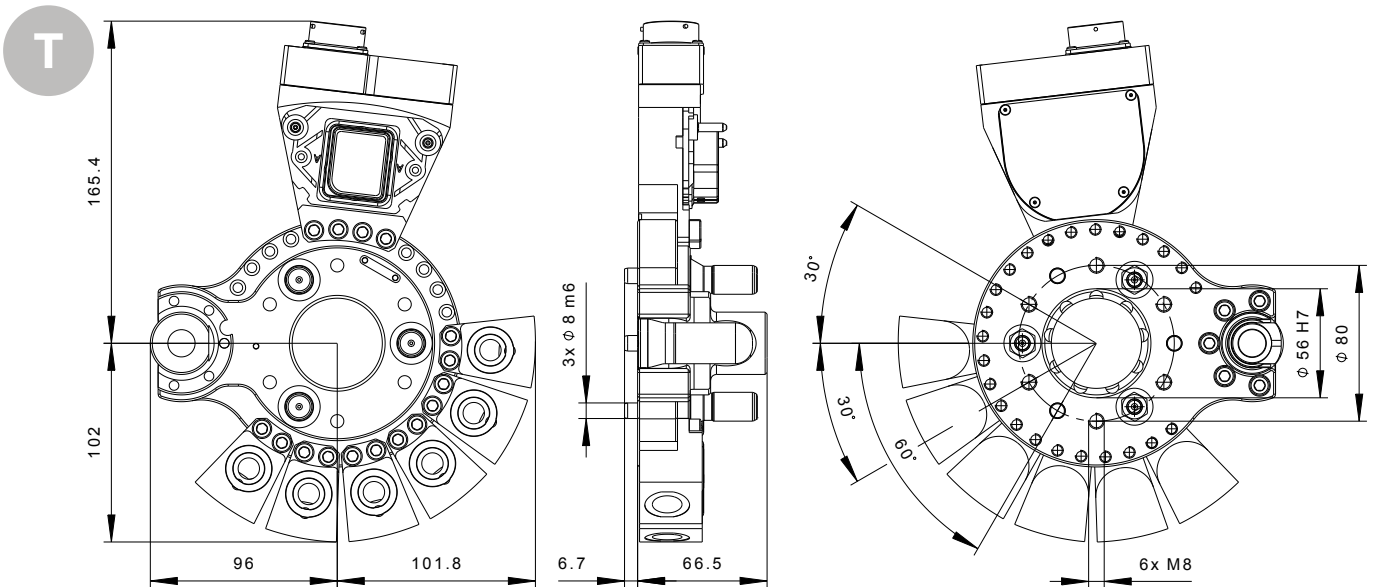
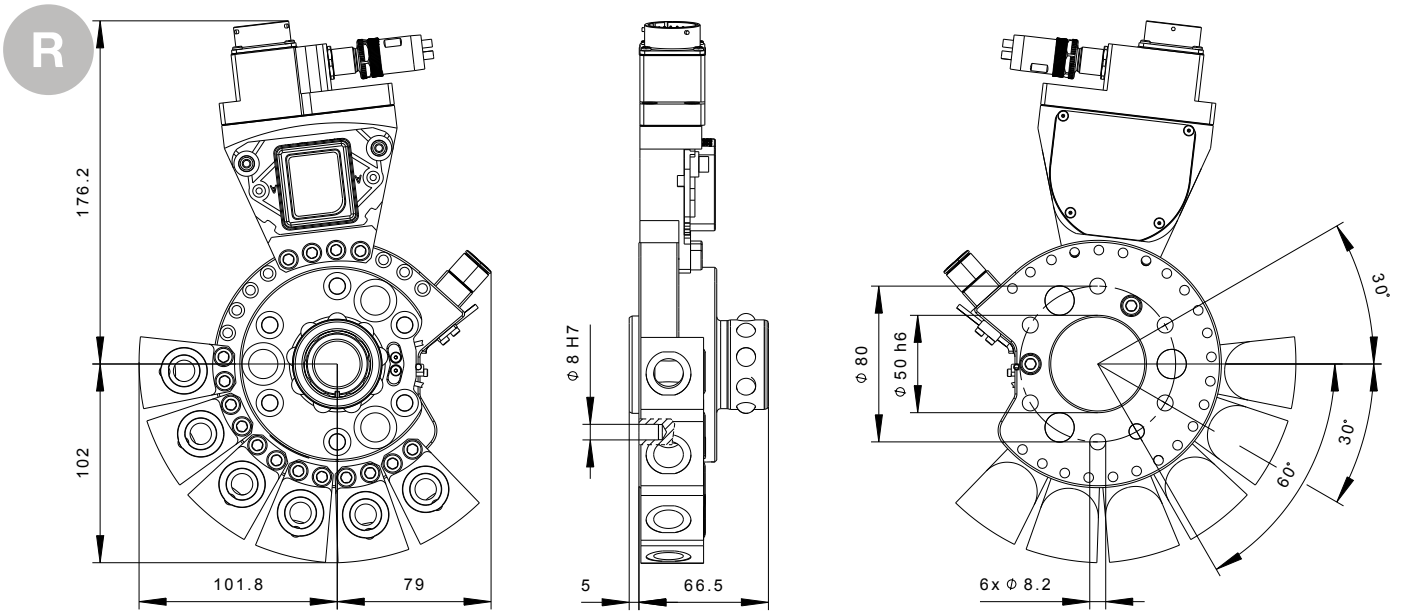

MPS 080 MODULAR

4 easy steps to your modular solution

Take advantage of Stäubli's modular product concept for maximum design freedom.
Configure your perfect tool changing system in just 4 easy steps.

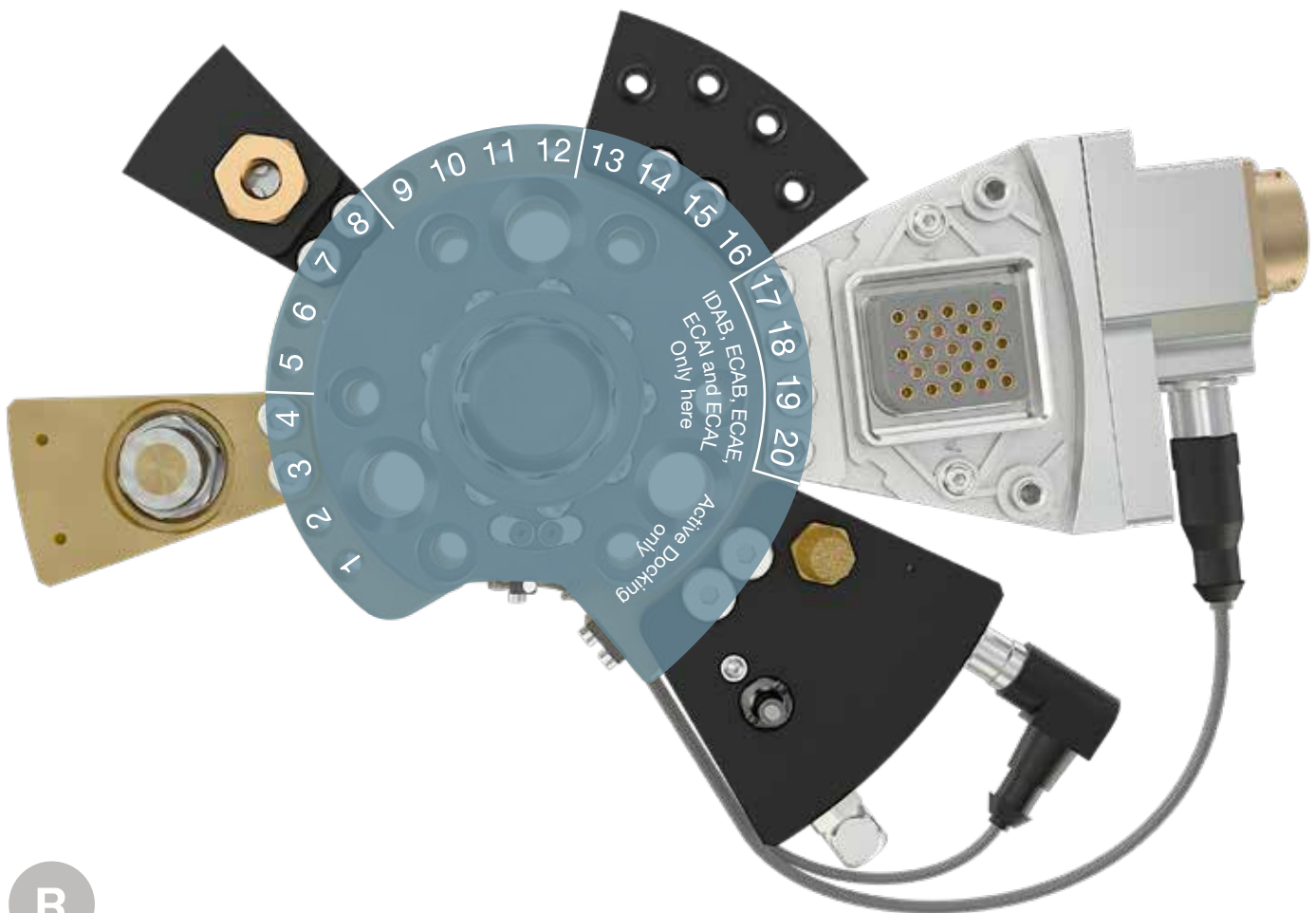

R

1 Choose your **base unit** (page 28) and note the module order code.

2 Choose your **transfer modules** (from page 84 onwards). Position the modules on the mounting holes 1 to 20 by entering the module order code. IDAB, ECAB, ECAE, ECAL and ECAL must be mounted in hole positions 17 to 20.

M P S 0 8 0 R D - 0 0 W A - 0 0 W B - 0 0 0 0 - P 4 W P - E C A B
1 2 3 4 5 6 7 8 9 10 11 12 13 14 15 16 17 18 19 20

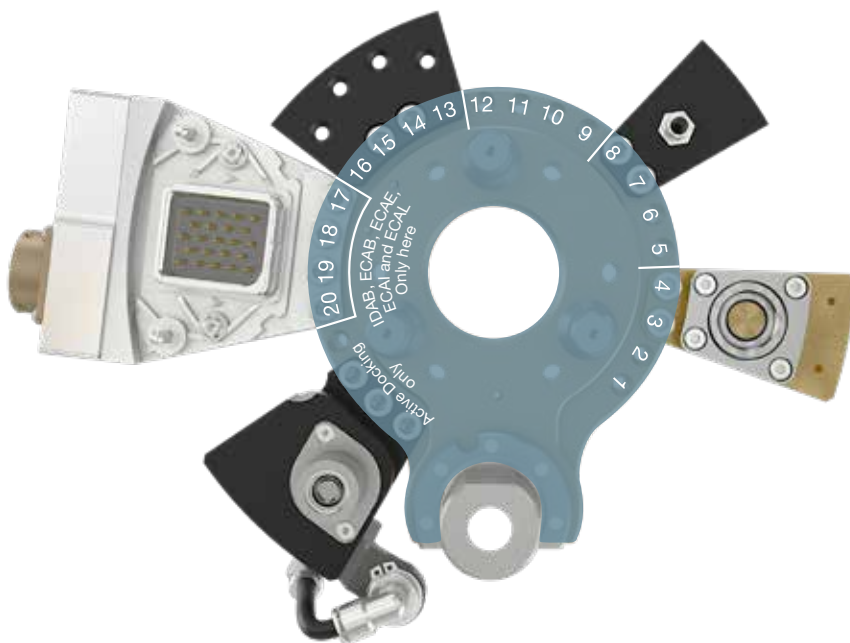

T

3 Select the appropriate **base unit** for your tool side (from page 30).
 Transfer the module order codes of the **transfer modules** corresponding to the robot side.

M P S O 8 0 T C - 0 0 W A - 0 0 W B - 0 0 0 0 - P 4 W P - E C A B
 1 2 3 4 5 6 7 8 9 10 11 12 13 14 15 16 17 18 19 20

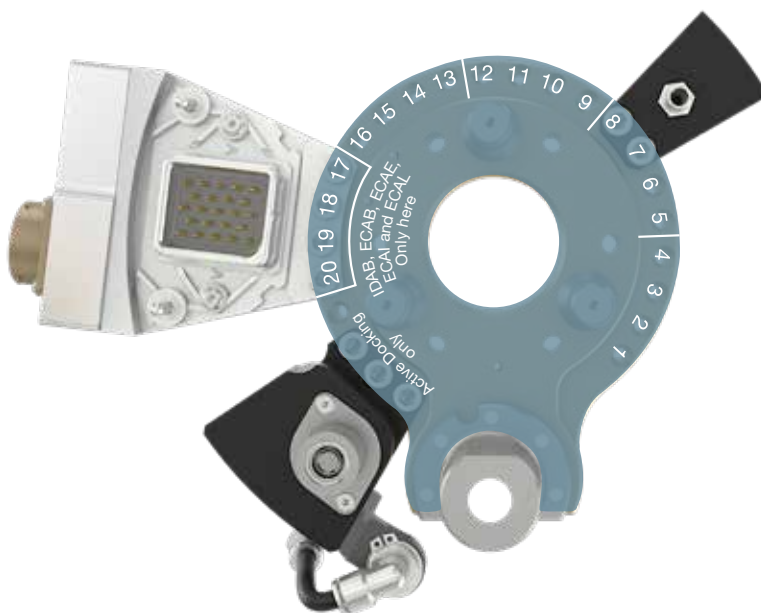

T

4 **Reduce your investment** by varying your tool side and removing any transfer modules that aren't needed (Replace module order code with 00 or 0000).

M P S O 8 0 T C - 0 0 0 0 - 0 0 W B - 0 0 0 0 - 0 0 0 0 - E C A B
 1 2 3 4 5 6 7 8 9 10 11 12 13 14 15 16 17 18 19 20

MPS 080 MODULAR

MPS 080 base unit robot side

MPS080RA/RE

R

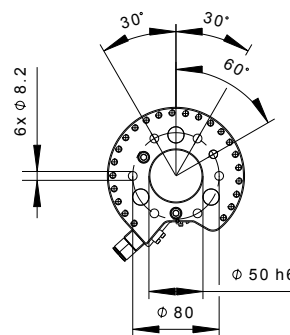
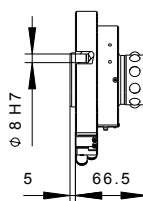
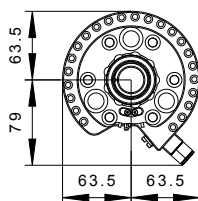
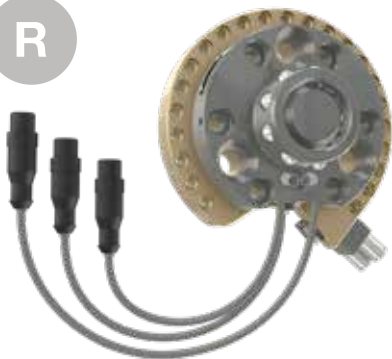

MPS080RB/RF

R

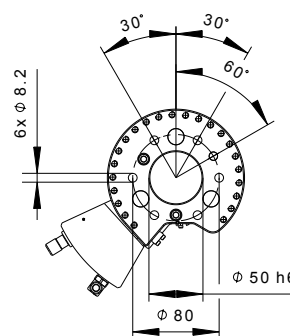
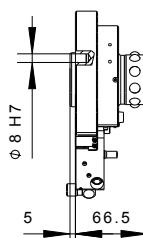
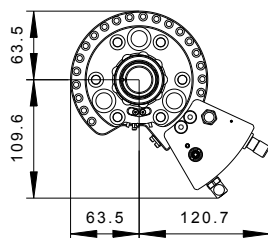

	Order no.	Pitch circle diameter (PCD)	Bending moment	Torsional moment	Payload	Compressed air connection	Safety module	Sensors/ connection	Module order code
R	K81557785	Ø 80 mm	286 Nm	286 Nm	80 kg	Push-lock-hose-Ø 6 mm	-	3x PNP/ 3x M12	MPS080RA
	3x NPN/ 3x M12							MPS080RE	
R	K81557787	Ø 80 mm	286 Nm	286 Nm	80 kg	Push-lock-hose-Ø 6 mm	Pressure switch PNP/ NPN 1x M12	3x PNP/ 3x M12	MPS080RB
	3x NPN/ 3x M12							MPS080RF	

MPS080RC/RG



R

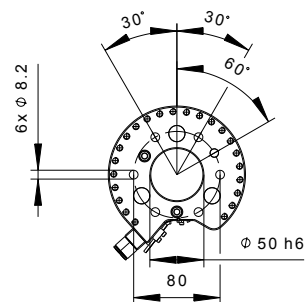
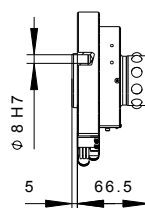
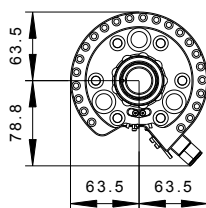

MPS080RD/RH



R

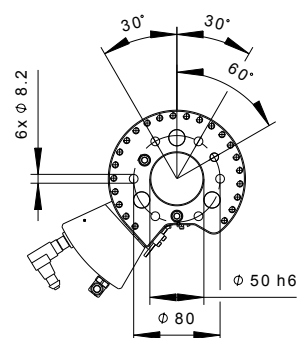
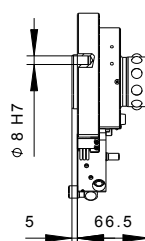
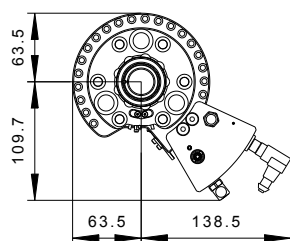

	Order no.	Pitch circle diameter (PCD)	Bending moment	Torsional moment	Payload	Compressed air connection	Safety module	Sensors/ connection	Module order code
R	K81557789	Ø 80 mm	286 Nm	286 Nm	80 kg	Push-lock-hose-Ø 6 mm	-	3x PNP/ 1x M12 8-pole	MPS080RC
	K81557790							3x NPN/ 1x M12 8-pole	MPS080RG
R	K81557791	Ø 80 mm	286 Nm	286 Nm	80 kg	Push-lock-hose-Ø 6 mm	Pressure switch PNP/ NPN 1x M12	3x PNP/ 1x M12 8-pole	MPS080RD
	K81557792							3x NPN/ 1x M12 8-pole	MPS080RH

MPS 080 MODULAR

MPS 080 base unit tool side

MPS080TO

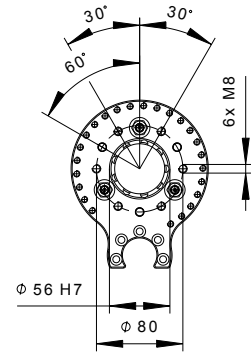
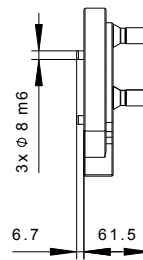
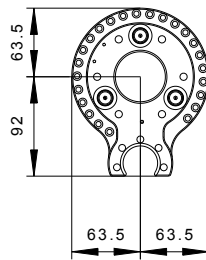

MPS080TB

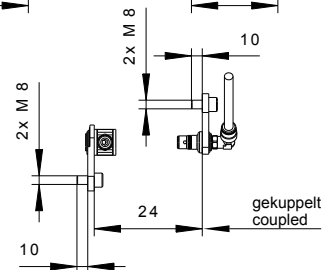
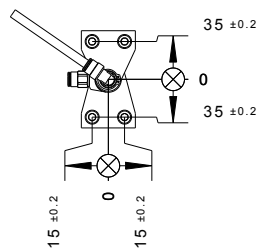
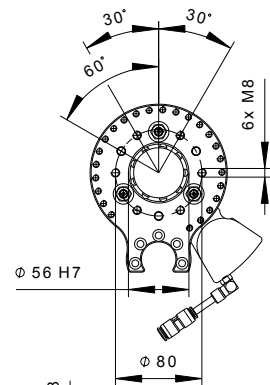
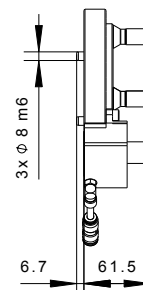
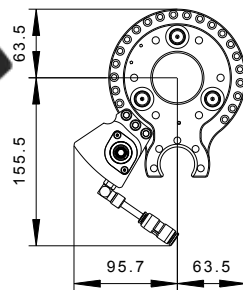

MPS080TA

T

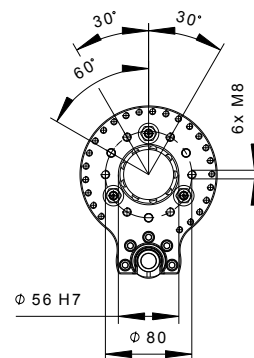
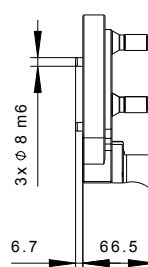
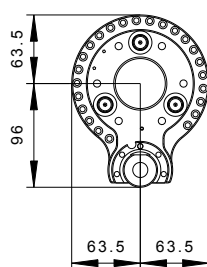

MPS080TC

T

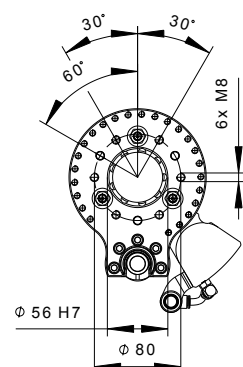
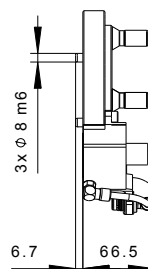
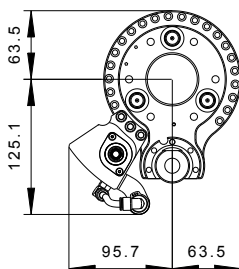

	Order no.	Pitch circle diameter (PCD)	Bending moment	Torsional moment	Docking hook	Safety module	Module order code
T	K81557946	Ø 80 mm	286 Nm	286 Nm	no	no	MPS080TO
T	K81557947	Ø 80 mm	286 Nm	286 Nm	no	yes	MPS080TB
T	K81557948	Ø 80 mm	286 Nm	286 Nm	yes	no	MPS080TA
T	K81557949	Ø 80 mm	286 Nm	286 Nm	yes	yes	MPS080TC

MPS 080 ACCESSORIES

MPS 080 Accessories

Robot side mounting kit



Order no.	Pitch diameter	Mounting materials	Strength class*	Locating pin
K81574216	Ø 80 mm	(6x) M8x45	12.9	(1x) 8/20

* The specifications of the robot manufacturers must be observed. If the specifications are different, use the corresponding strength classes.

Emergency release



Order no.	Description
K81558336	Tool for emergency release

Teaching aid



Order no.	Description
K81557999	Teaching aid for the robot tool change system
K81557998	Storage case including teaching aid for the robot tool change system

MPS 130 COMPLETE

MPS 130/1

For handling and gripping applications

R



T



Application	Sensors		Connection transfer modules*		Order no.
			Pneumatic	Signal	
Gripping/ handling	R	PNP	1x G 1/8	KPTC2E18-32P	MPS130RC-0000-0000-0000-0000-00WB-ECAB
	R	NPN			MPS130RG-0000-0000-0000-0000-00WB-ECAB
	T	-		KPTC2E18-32S	MPS130TA-0000-0000-0000-0000-00WB-ECAB

Technical data for the base unit on the robot and tool sides can be found on page 42.
 * Technical data for all transfer modules can be found from page 84 onwards.



Transfer modules with alternative thread and plug connections can be customized using our **simple configuration system** (see page 40).

R

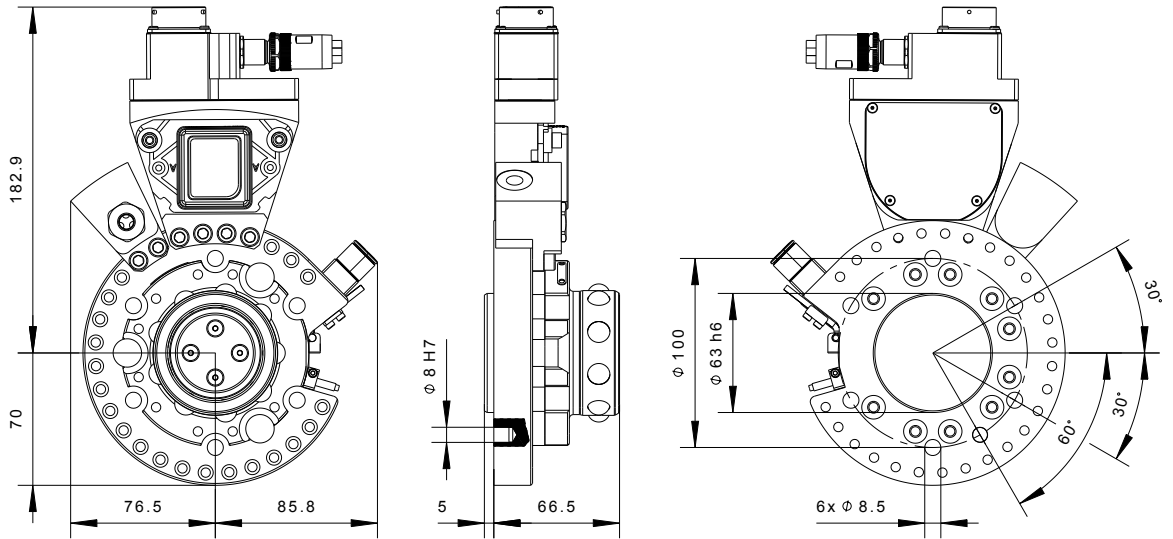

T

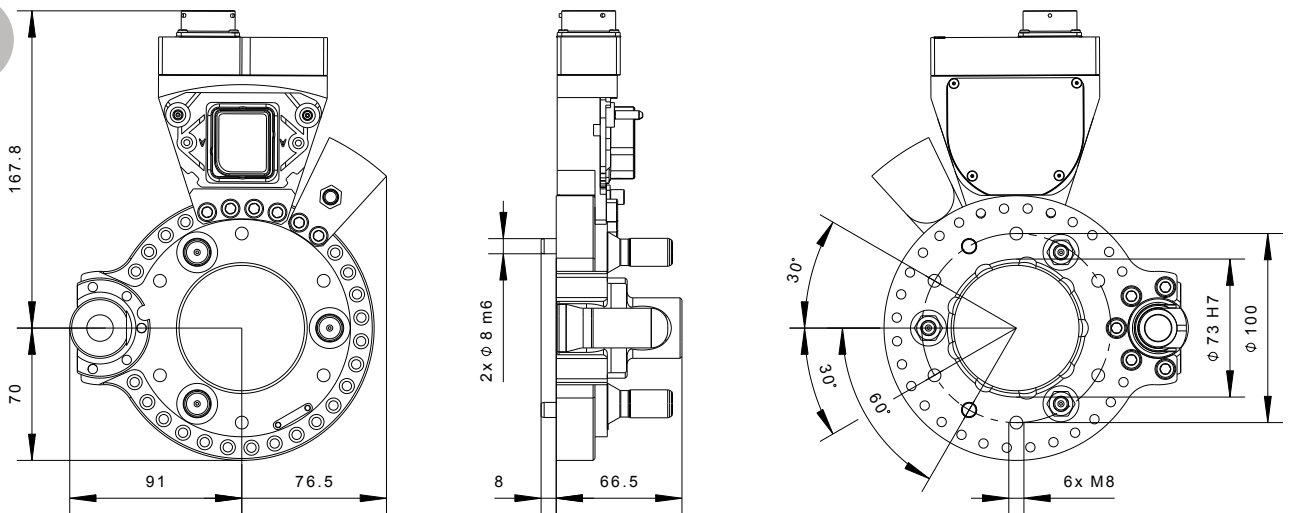

MPS 130 COMPLETE

MPS 130/2

For handling, gripping and vacuum applications

R

T

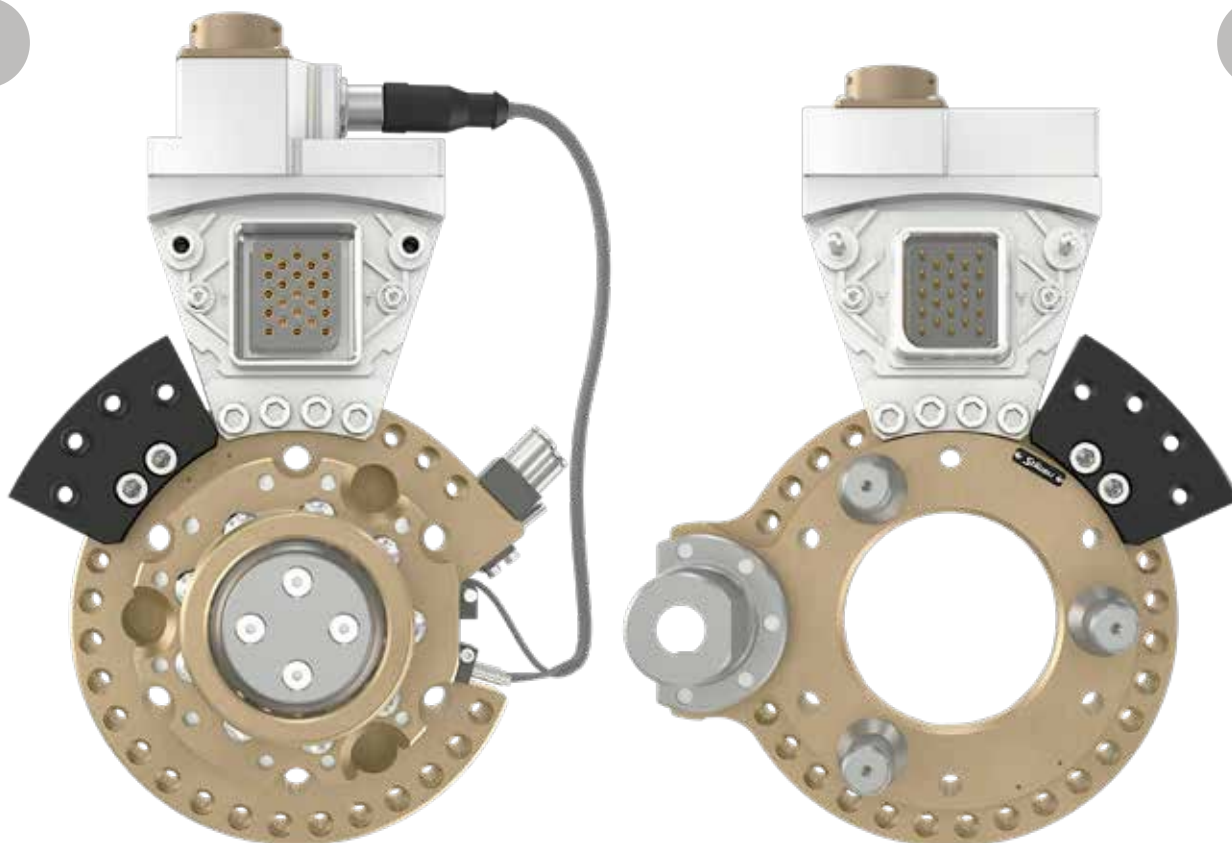

Application		Sensors	Connection transfer modules*		Order no.
			Pneumatic	Signal	
Gripping/ handling/ vacuum	R	PNP	4x G 1/8	KPTC2E18-32P	MPS130RC-0000-0000-0000-0000-P4WP-ECAB
	R	NPN			MPS130RG-0000-0000-0000-0000-P4WP-ECAB
	T	-		KPTC2E18-32S	MPS130TA-0000-0000-0000-0000-P4WP-ECAB

Technical data for the base unit on the robot and tool sides can be found on page 42.
 * Technical data for all transfer modules can be found from page 84 onwards.



Transfer modules with alternative thread and plug connections can be customized using our **simple configuration system** (see page 40).

R

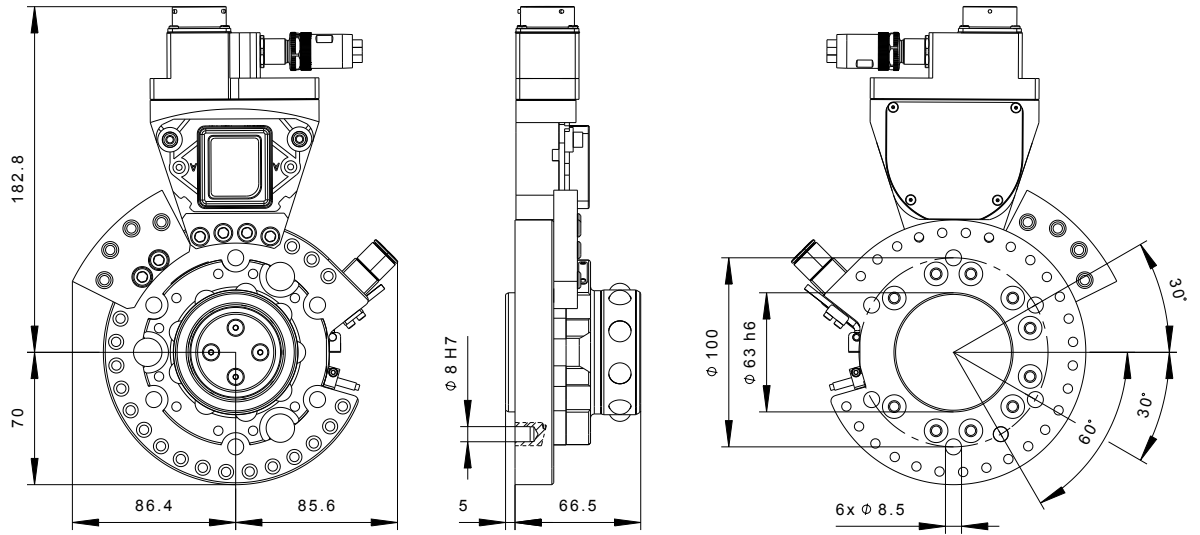

T

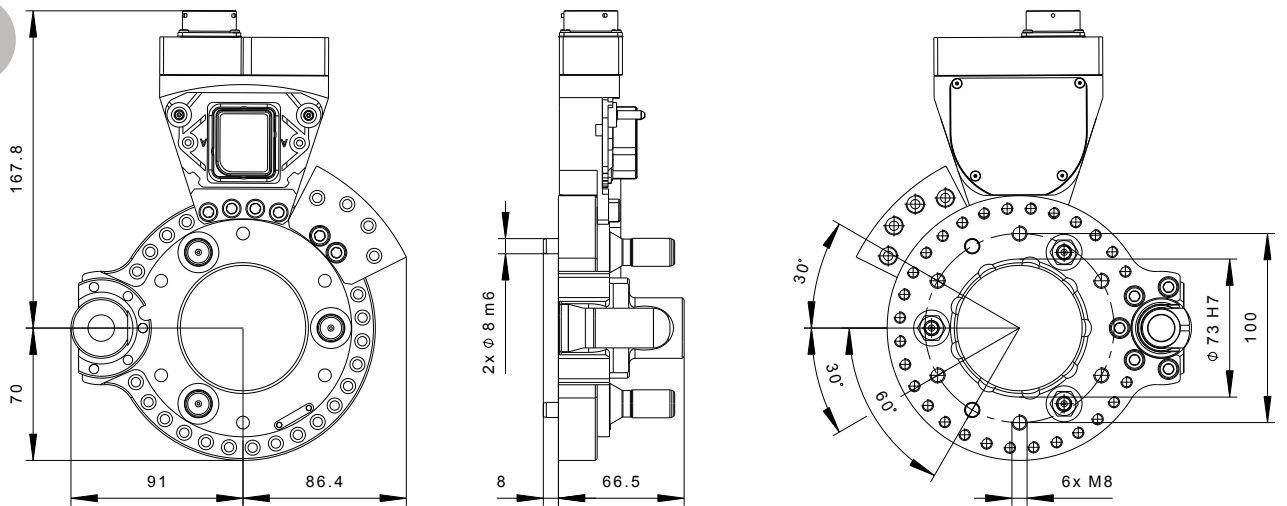

MPS 130 COMPLETE

MPS 130/3

For handling, gripping and vacuum applications

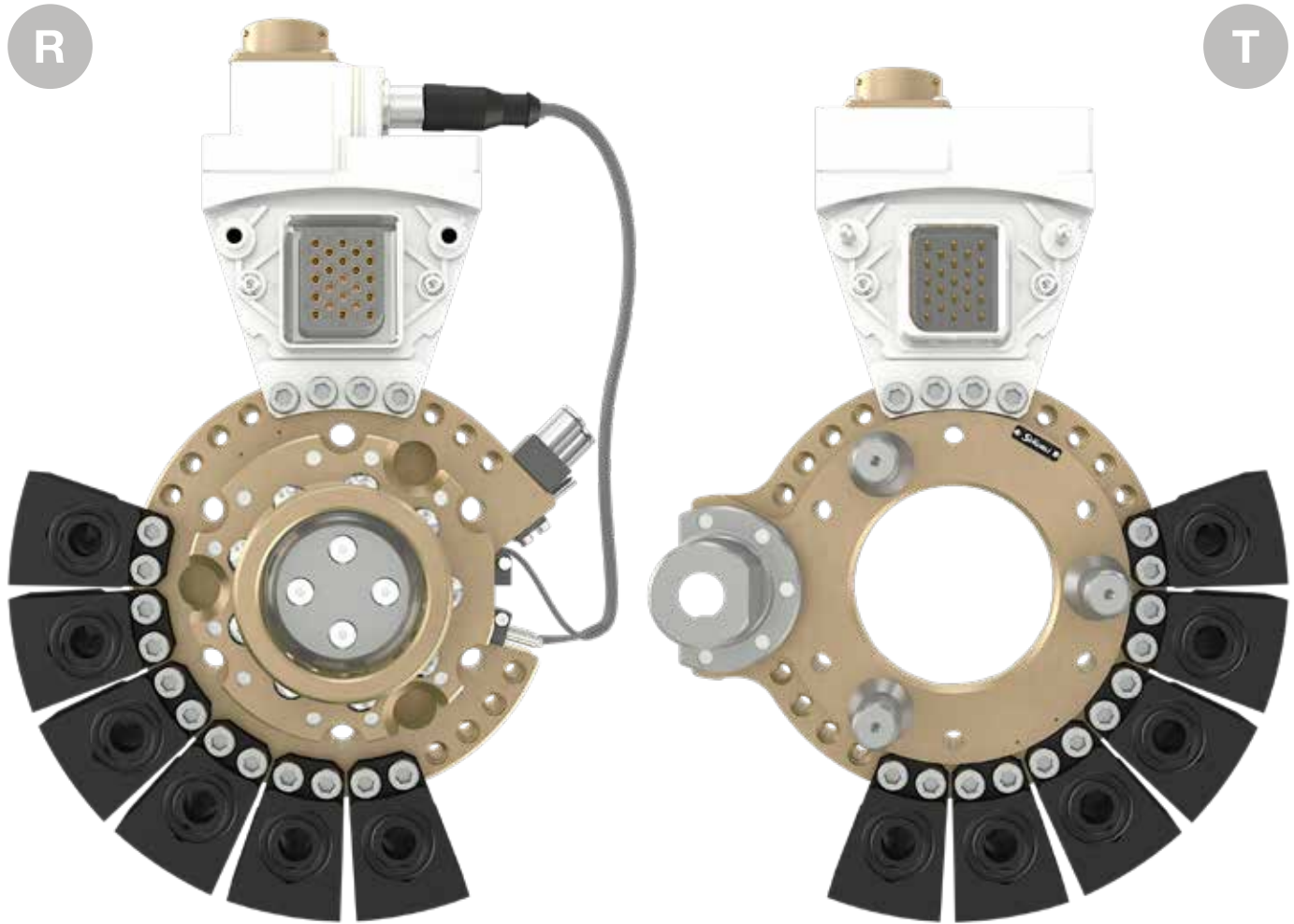

Application	Sensors	Connection transfer modules*		Order no.
		Pneumatic	Signal	
Gripping/ handling/ vacuum	R PNP	6x G 3/8	KPTC2E18-32P	MPS130RC-0000-WEWE-WEWE-WEWE-0000-ECAB
	R NPN			MPS130RG-0000-WEWE-WEWE-WEWE-0000-ECAB
	T -			KPTC2E18-32S

Technical data for the base unit on the robot and tool sides can be found on page 42.
 * Technical data for all transfer modules can be found from page 84 onwards.

 Transfer modules with alternative thread and plug connections can be customized using our simple configuration system (see page 40).

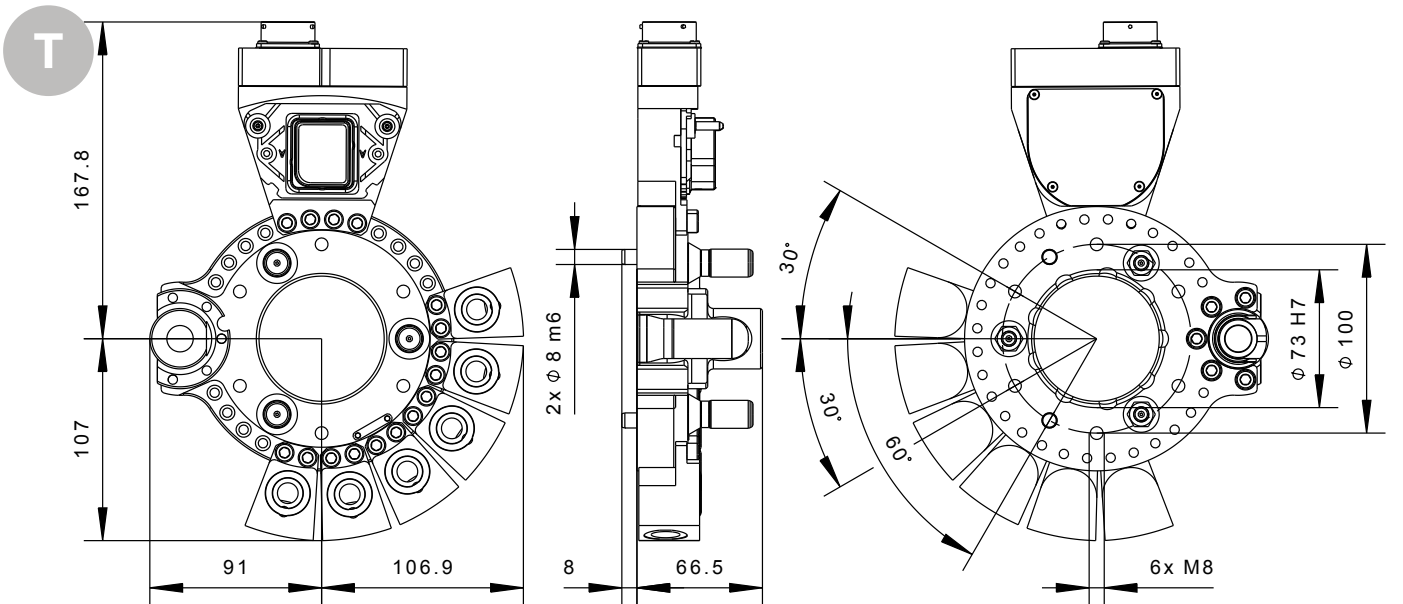
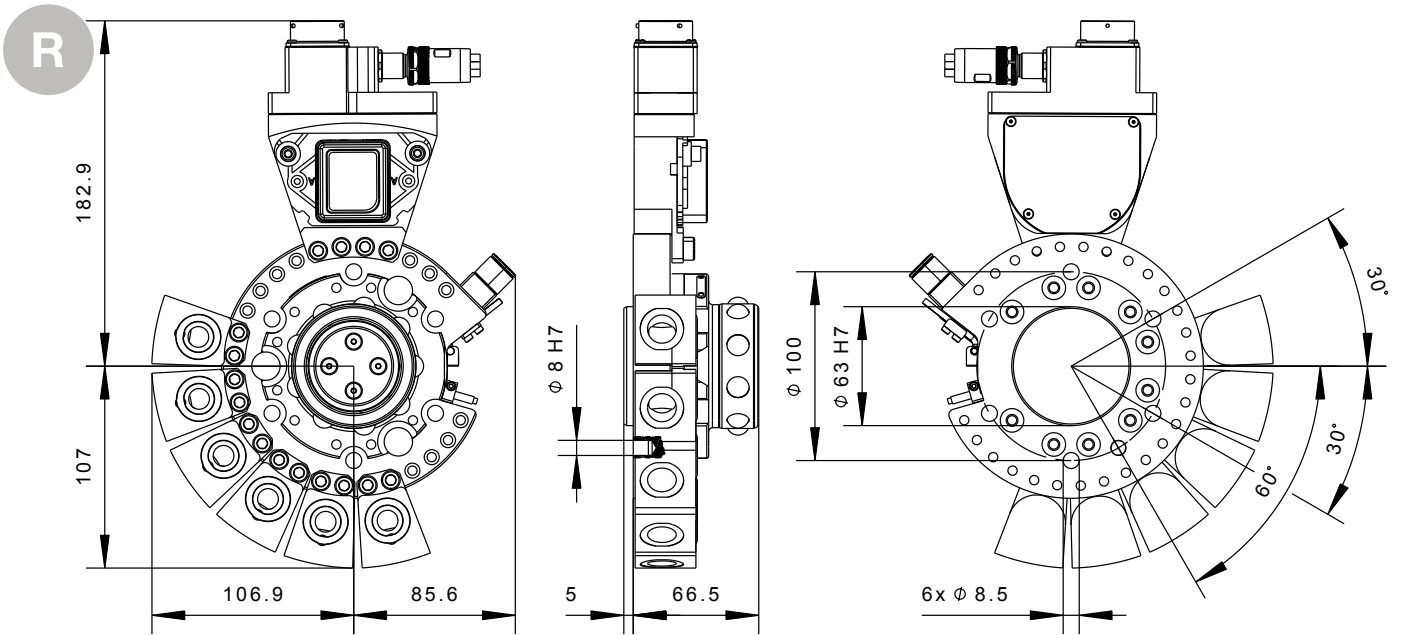

MPS 130 MODULAR

4 easy steps to your modular solution

Take advantage of Stäubli's modular product concept for maximum design freedom.
Configure your perfect tool changing system in just 4 easy steps.

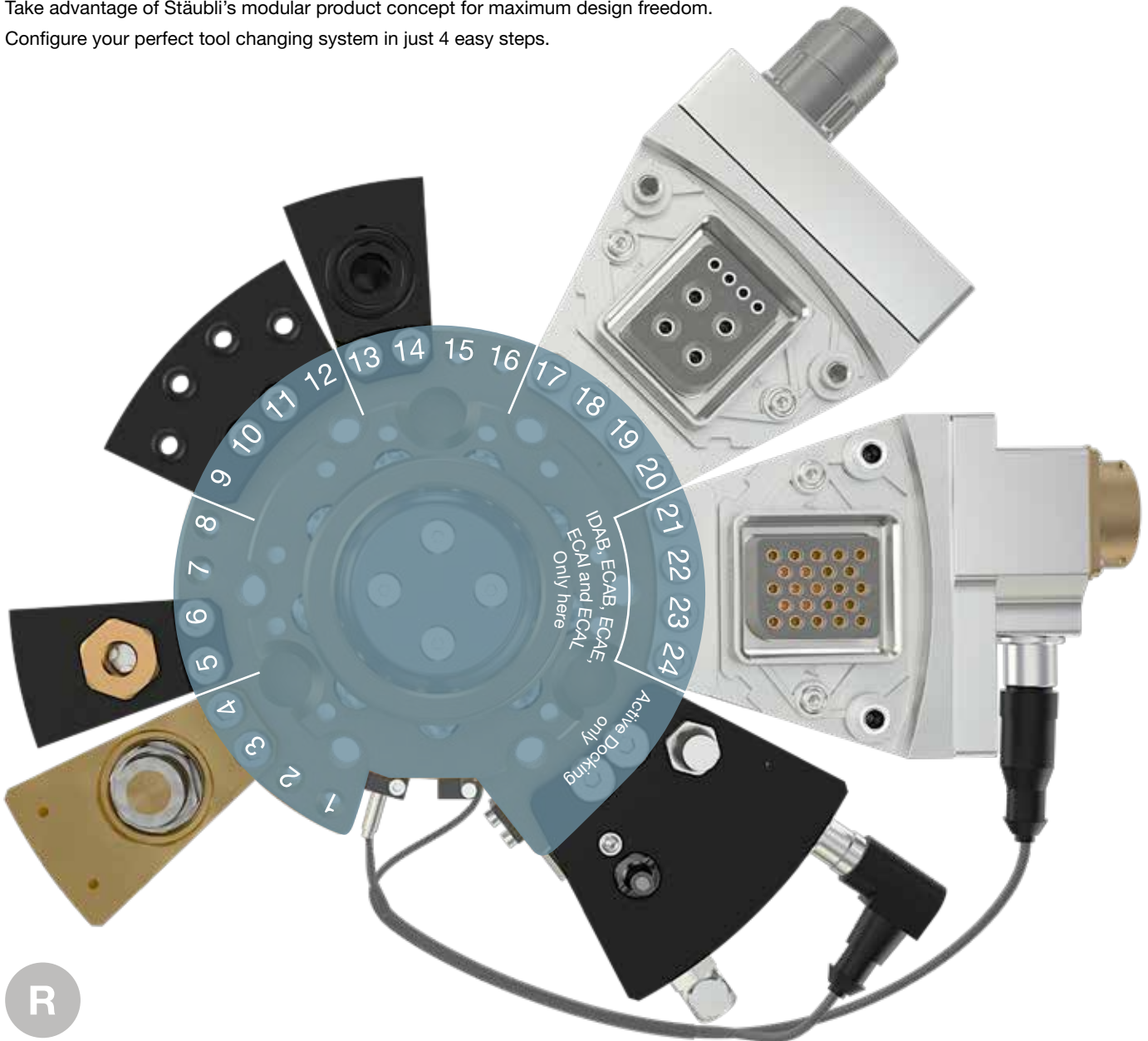

R

1 Choose your **base unit** (page 42) and note the module order code.

2 Choose your **transfer modules** (from page 84 onwards). Position the modules on the mounting holes 1 to 24 by entering the module order code. IDAB, ECAB, ECAE, ECAI and ECAL must be mounted in hole positions 21 to 24. All modules starting with "EC" cannot be mounted at module space 1-4.

M P S 1 3 0 R D - 0 0 W A - W B 0 0 - P 4 W P - W E 0 0 - E C A C - E C A B
 1 2 3 4 5 6 7 8 9 10 11 12 13 14 15 16 17 18 19 20 21 22 23 24

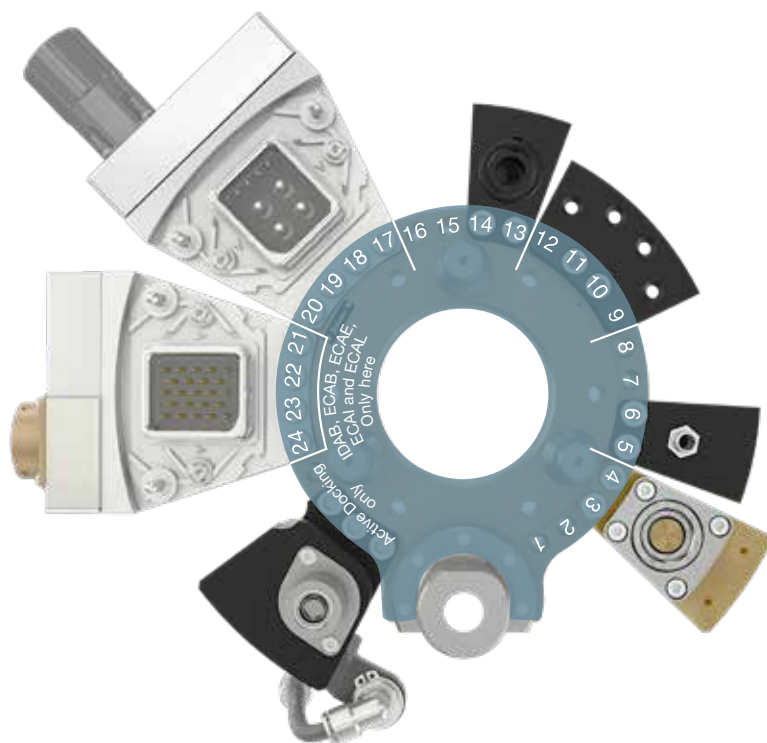

T

3 Select the appropriate **base unit** for your tool side (from page 44).
 Transfer the module order codes of the **transfer modules** corresponding to the robot side.

M P S 1 3 0 T C - 0 0 W A - W B 0 0 - P 4 W P - W E 0 0 - E C A C - E C A B
 1 2 3 4 5 6 7 8 9 10 11 12 13 14 15 16 17 18 19 20 21 22 23 24

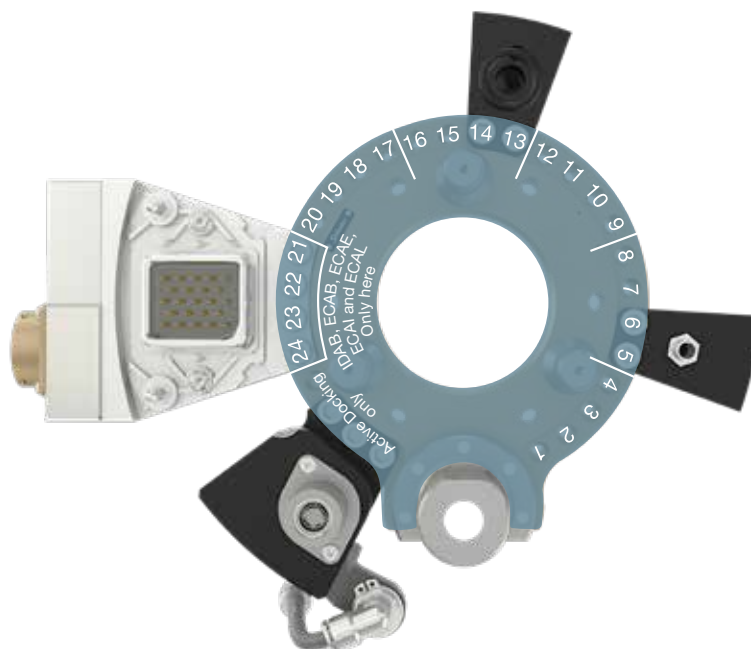

T

4 **Reduce your investment** by varying your tool side and removing any transfer modules that aren't needed (Replace module order code with 00 or 0000).

M P S 1 3 0 T C - 0 0 0 0 - W B 0 0 - 0 0 0 0 - W E 0 0 - 0 0 0 0 - E C A B
 1 2 3 4 5 6 7 8 9 10 11 12 13 14 15 16 17 18 19 20 21 22 23 24

MPS 130 MODULAR

MPS 130 base unit robot side

MPS130RA/RE

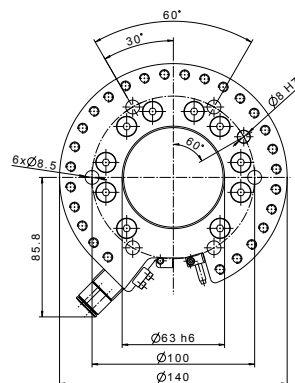
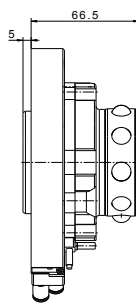
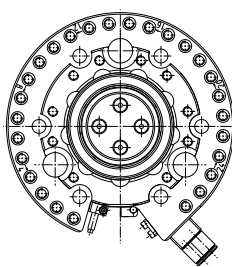

MPS130RB/RF

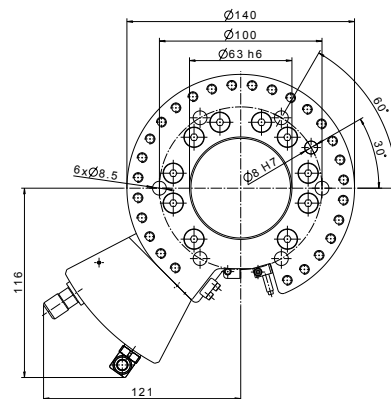
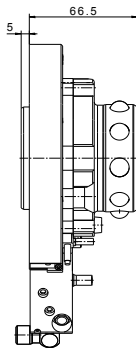
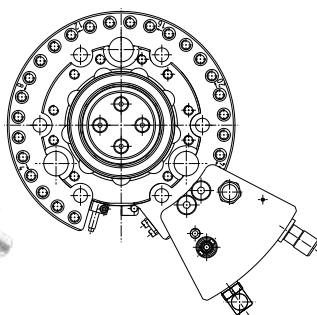

	Order no.	Pitch circle diameter (PCD)	Bending moment	Torsional moment	Payload	Compressed air connection	Safety module	Sensors/ connection	Module order code
R	K81557713	Ø 100 mm	900 Nm	800 Nm	100 kg	Push-lock-hose-Ø 6 mm	-	3x PNP/ 3x M12	MPS130RA
	K81557739							3x NPN/ 3x M12	MPS130RE
R	K81557714	Ø 100 mm	900 Nm	800 Nm	100 kg	Push-lock-hose-Ø 6 mm	Pressure switch PNP/ NPN 1x M12	3x PNP/ 3x M12	MPS130RB
	K81557740							3x NPN/ 3x M12	MPS130RF

MPS130RC/RG

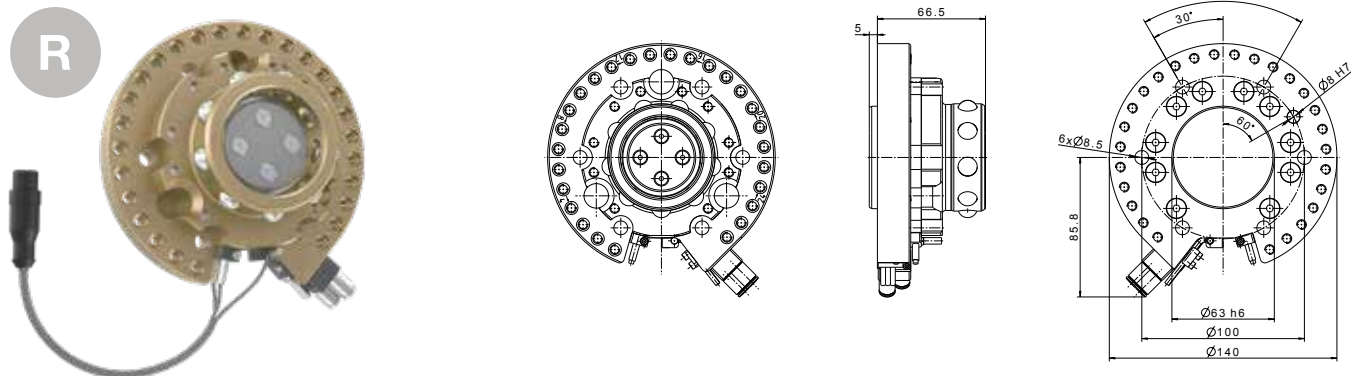

MPS130RD/RH

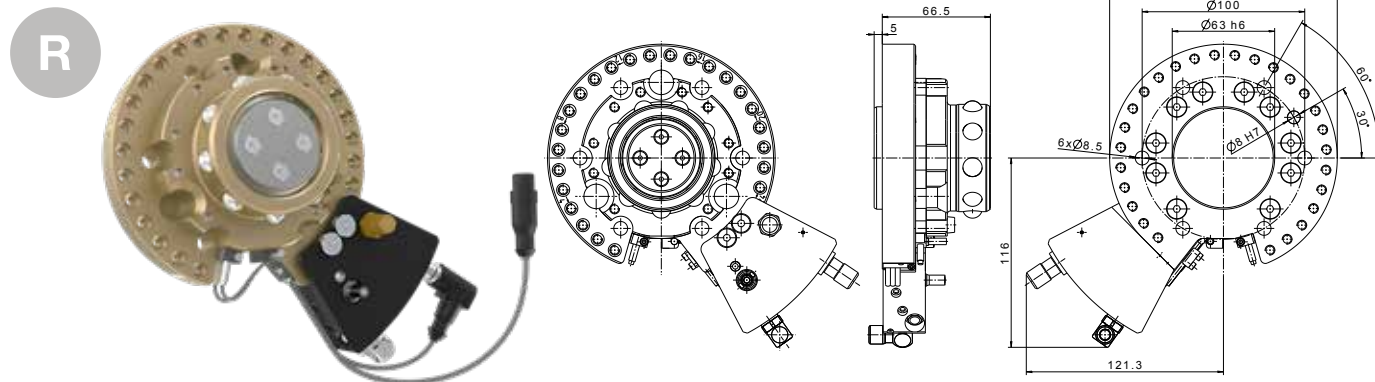

	Order no.	Pitch circle diameter (PCD)	Bending moment	Torsional moment	Payload	Compressed air connection	Safety module	Sensors/ connection	Module order code
R	K81557715	Ø 100 mm	900 Nm	800 Nm	100 kg	Push-lock-hose-Ø 6 mm	-	3x PNP/ 1x M12 8-pole	MPS130RC
	3x NPN/ 1x M12 8-pole							MPS130RG	
R	K81557716	Ø 100 mm	900 Nm	800 Nm	100 kg	Push-lock-hose-Ø 6 mm	Pressure switch PNP/ NPN 1x M12	3x PNP/ 1x M12 8-pole	MPS130RD
	3x NPN/ 1x M12 8-pole							MPS130RH	

MPS 130 MODULAR

MPS 130 base unit tool side

MPS130TO

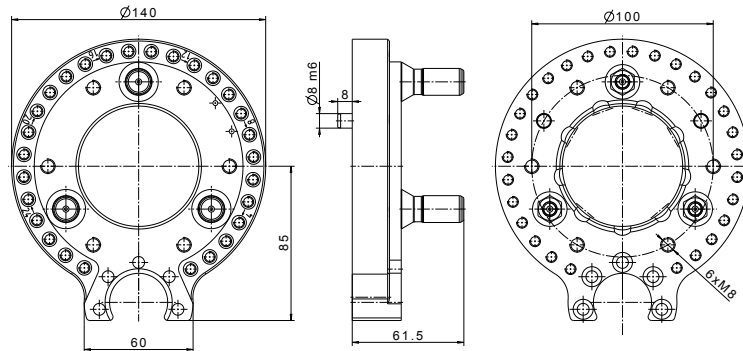

MPS130TB

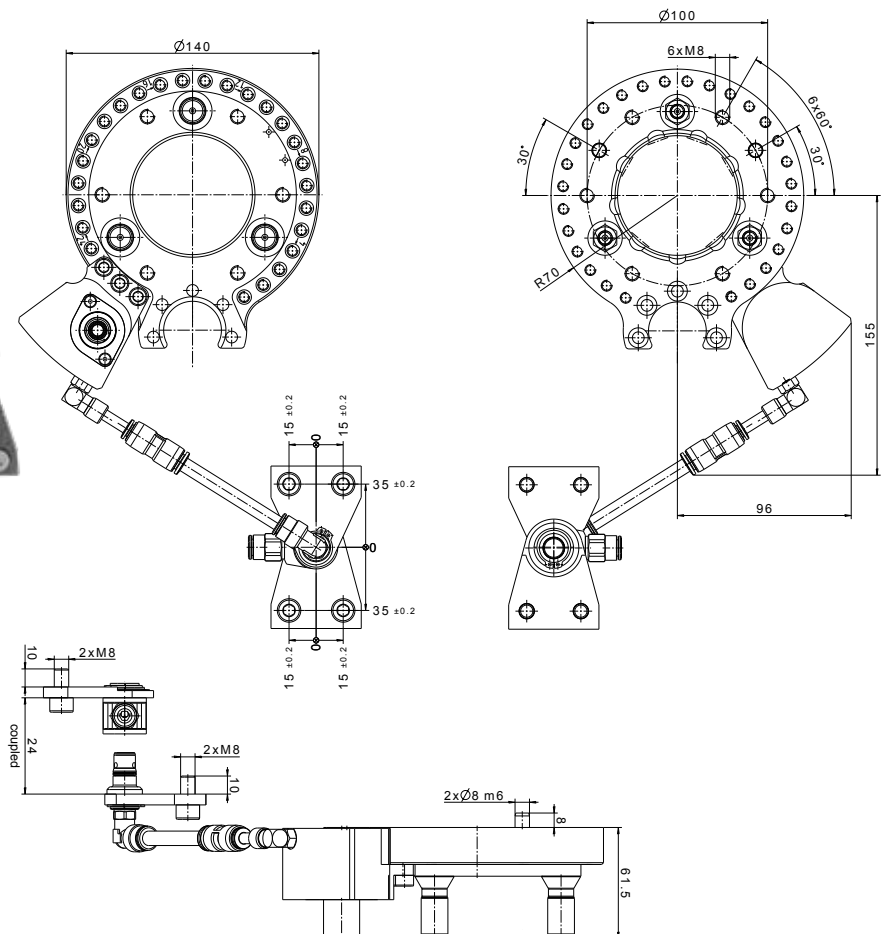

MPS130TA

T

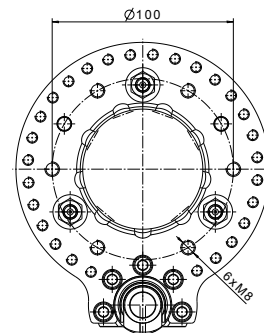
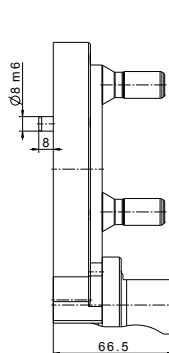
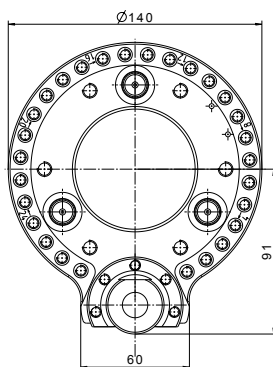

MPS130TC

T

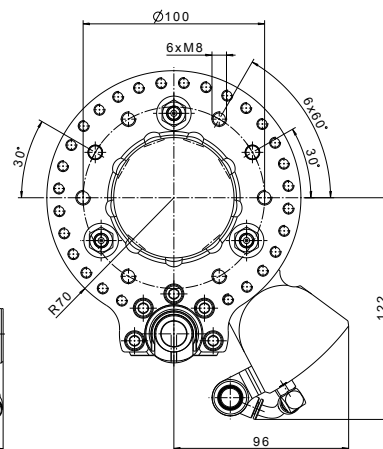
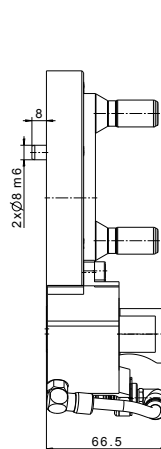
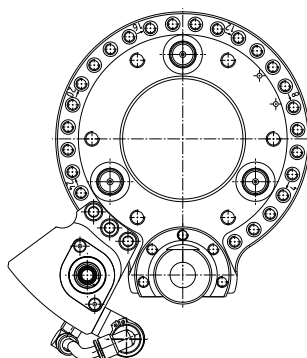

	Order no.	Pitch circle diameter (PCD)	Bending moment	Torsional moment	Docking hook	Safety module	Module order code
T	K81557661	Ø 100 mm	900 Nm	800 Nm	no	no	MPS130TO
T	K81557667	Ø 100 mm	900 Nm	800 Nm	no	yes	MPS130TB
T	K81557664	Ø 100 mm	900 Nm	800 Nm	yes	no	MPS130TA
T	K81557668	Ø 100 mm	900 Nm	800 Nm	yes	yes	MPS130TC

MPS 130 Robot adapter flange

R

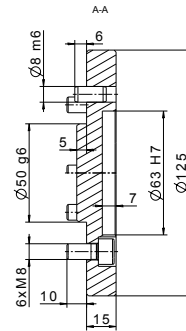
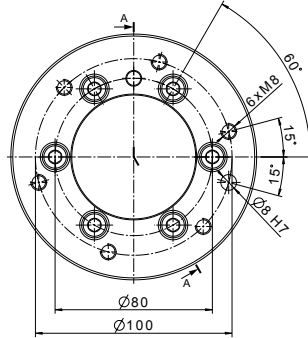

ill.1

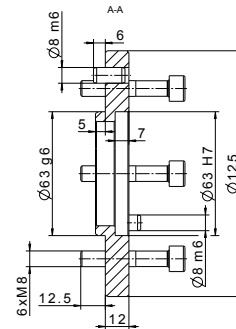
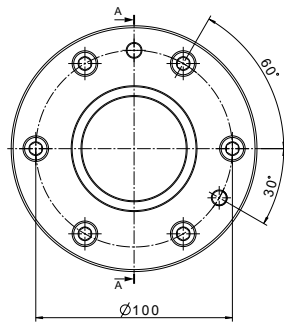

ill.2

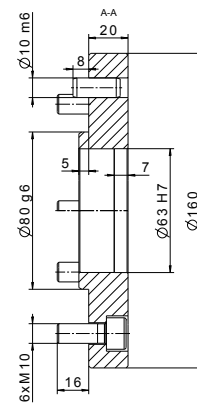
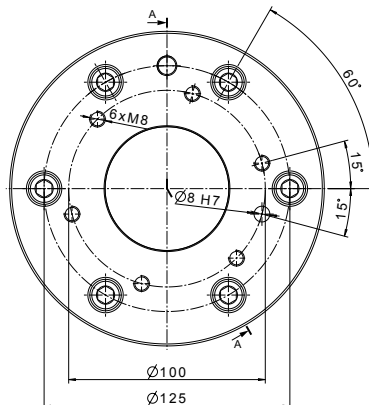

ill.3

ill.	Order no.*	Adaption to	Zero offset
R 1	K81558262	ISO 9409-1-80-6-M8	15°
R 2	K81558261	ISO 9409-1-100-6-M8	0°
R 3	K81558263	ISO 9409-1-125-6-M10	15°

* including mounting material.

MPS 130 Accessories

Robot side mounting kit



Order no.	Pitch diameter	Mounting materials	Strength class*	Locating pin
K81560778	Ø 100 mm	(6x) M8x30	12.9	(1x) 8/16

* The specifications of the robot manufacturers must be observed. If the specifications are different, use the corresponding strength classes.

Emergency release



Order no.	Description
K81558229	Tool for emergency release

Teaching aid



Order no.	Description
K81557695	Teaching aid for the robot tool change system
K81557691	Storage case including teaching aid for the robot tool change system

MPS 080/130 – Tool stand

Flexibility and efficiency due to integrated tool stand

The tool stand is consistent with Stäubli’s modular tool changer concept. Its individual components are designed to provide maximum scope for flexibility.

- Flexibility: the separate system components allow you to compile your own individual storage solutions.
- Optimisation: the complete systems are already dimensioned and calibrated for tool weights.
- Performance Level d, Category 3-compliant: the optional Active Docking System with self-contained compressed air circuit ensures that tool locking and unlocking can only take place at the tool stand.
- Longevity: the floating bearing of the docking pin holds the tool in the vertical storage position and minimises the load on the components.
- Function protection: a protective cover prevents any particles from getting into the transfer module couplings and connectors.



Contact us for individual solutions or special versions such as tool stand systems for two tools.

Tool stand base	Positioning plate	Tool stand upper part	Protective cover	Sensors/ connection	Valve/ connection	Order no.	ill.
H = 1000 mm	with	without Active Docking	without	1x PNP/ 1x M12	without	K85563000	1
				1x NPN/ 1x M12	without	K85563001	-
			with	3x PNP/ 3x M12	2x M8 4-pole	K85563002	2
				3x NPN/ 3x M12	2x M8 4-pole	K85563003	-
H = 1000 mm	with	with Active Docking	without	1x PNP/ 1x M12	1x M8 4-pole	K85563004	-
				1x NPN/ 1x M12	1x M8 4-pole	K85563005	-
			with	3x PNP/ 3x M12	3x M8 4-pole	K85563006	-
				3x NPN/ 3x M12	3x M8 4-pole	K85563007	-
H = 1000 mm	without	without Active Docking	without	1x PNP/ 1x M12	without	K85563008	3
				1x NPN/ 1x M12	without	K85563009	-
			with	3x PNP/ 3x M12	2x M8 4-pole	K85563010	4
				3x NPN/ 3x M12	2x M8 4-pole	K85563011	-
H = 1000 mm	without	with Active Docking	without	1x PNP/ 1x M12	1x M8 4-pole	K85563012	-
				1x NPN/ 1x M12	1x M8 4-pole	K85563013	-
			with	3x PNP/ 3x M12	3x M8 4-pole	K85563014	-
				3x NPN/ 3x M12	3x M8 4-pole	K85563015	-

Technical data for all the single components can be found on page 53.

iii.1

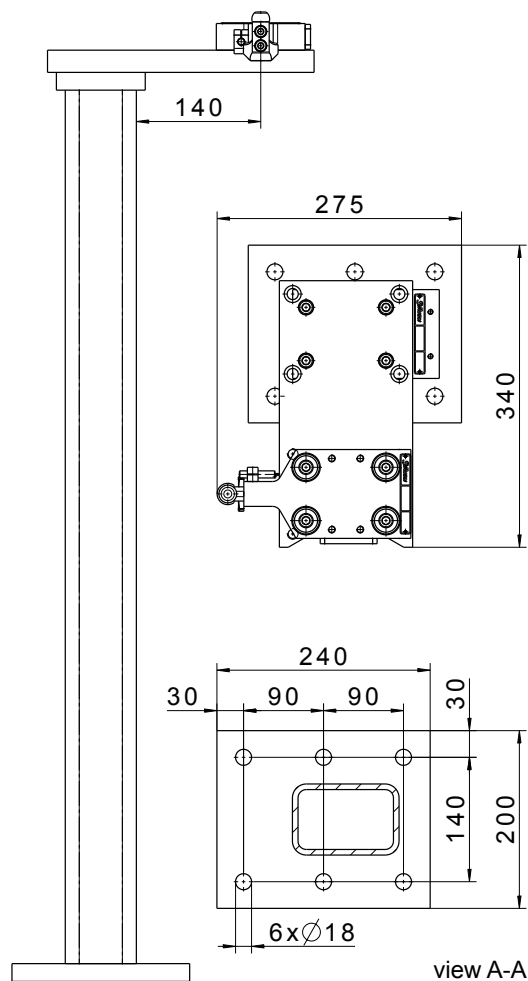
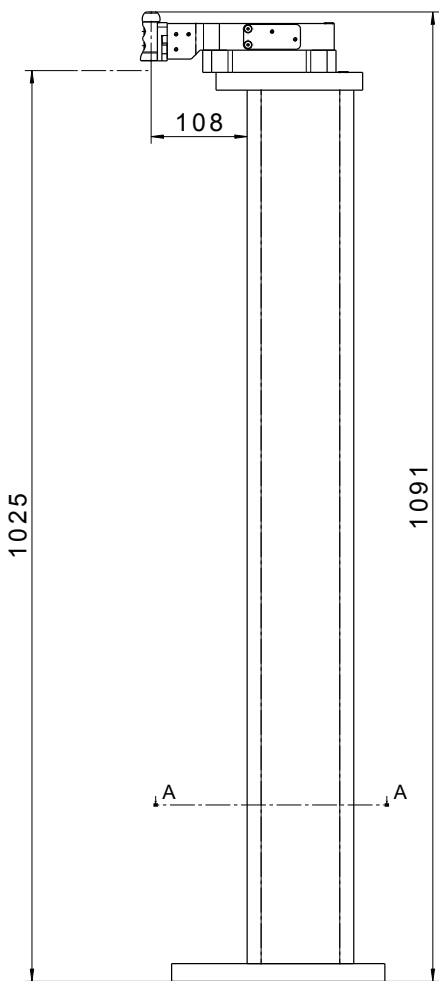

MPS 080/130 TOOL STAND

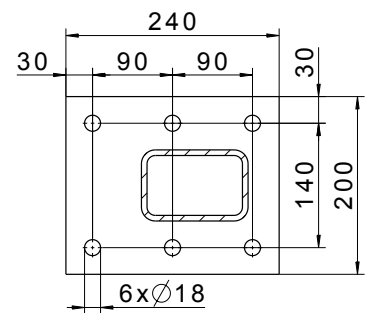
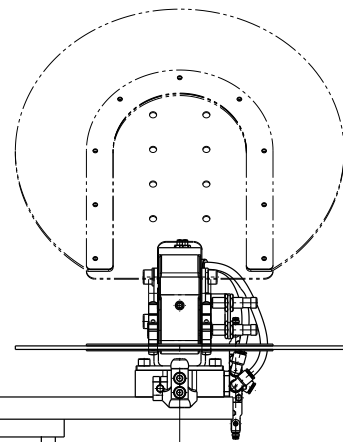
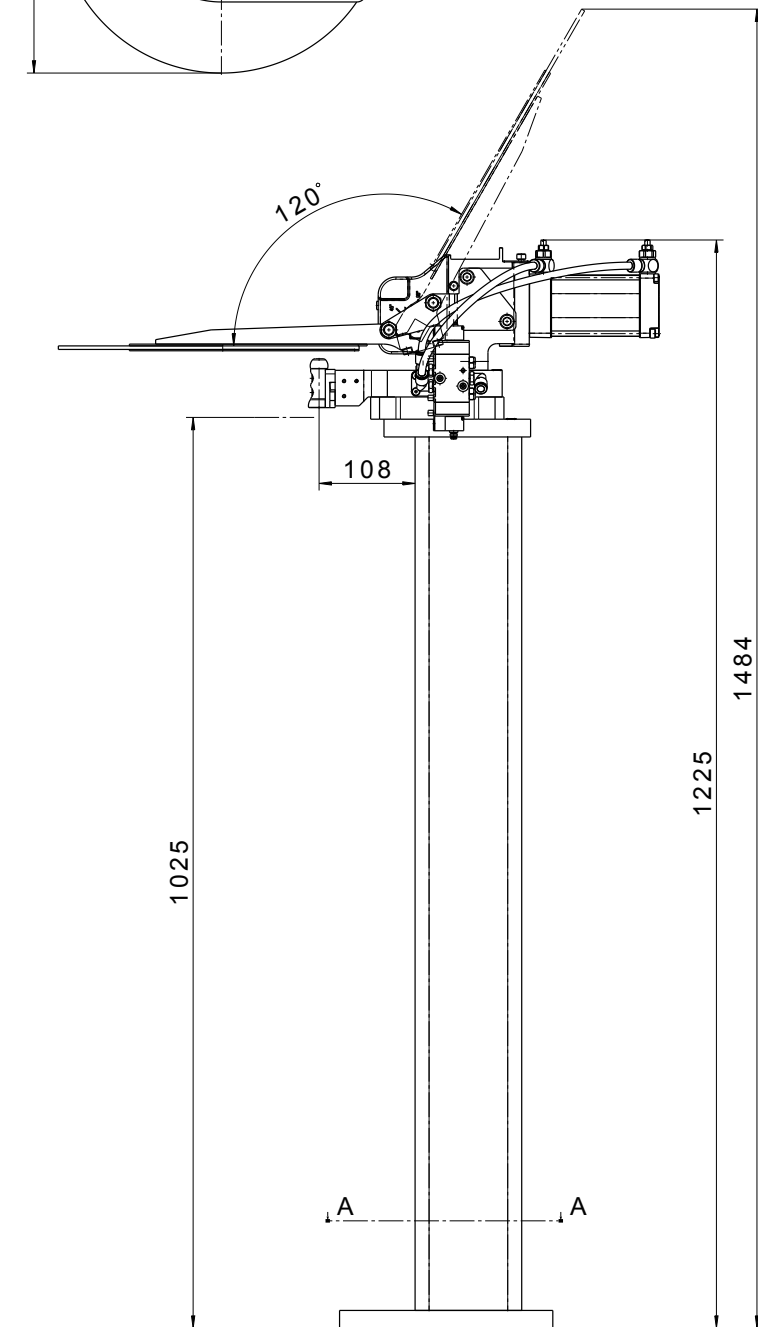
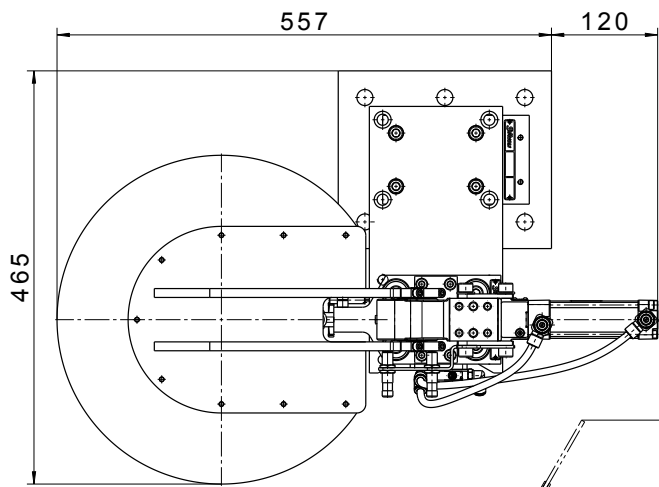

view A-A

iii.2

iii.3

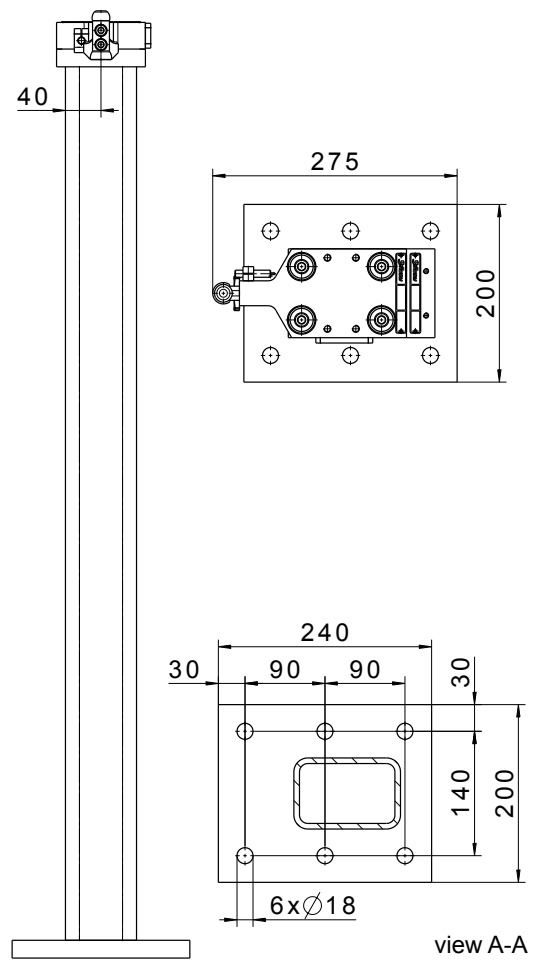
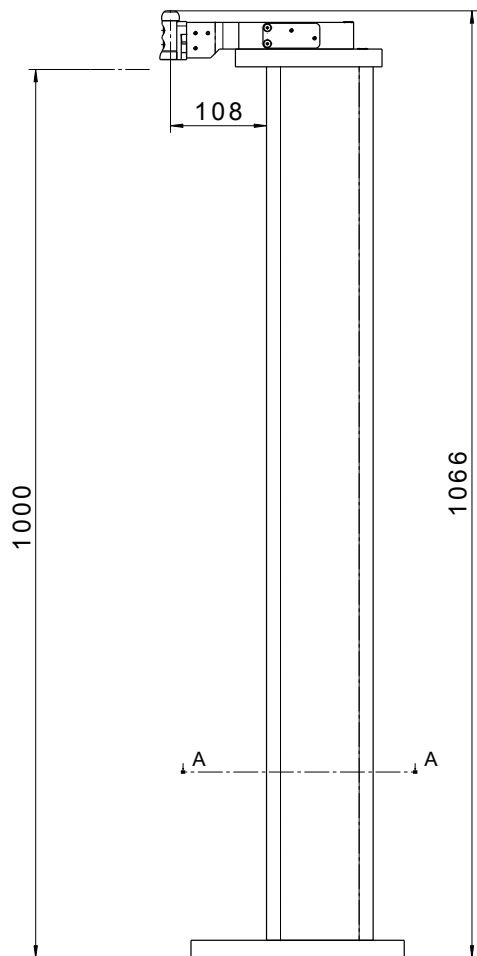

MPS 080/130 TOOL STAND

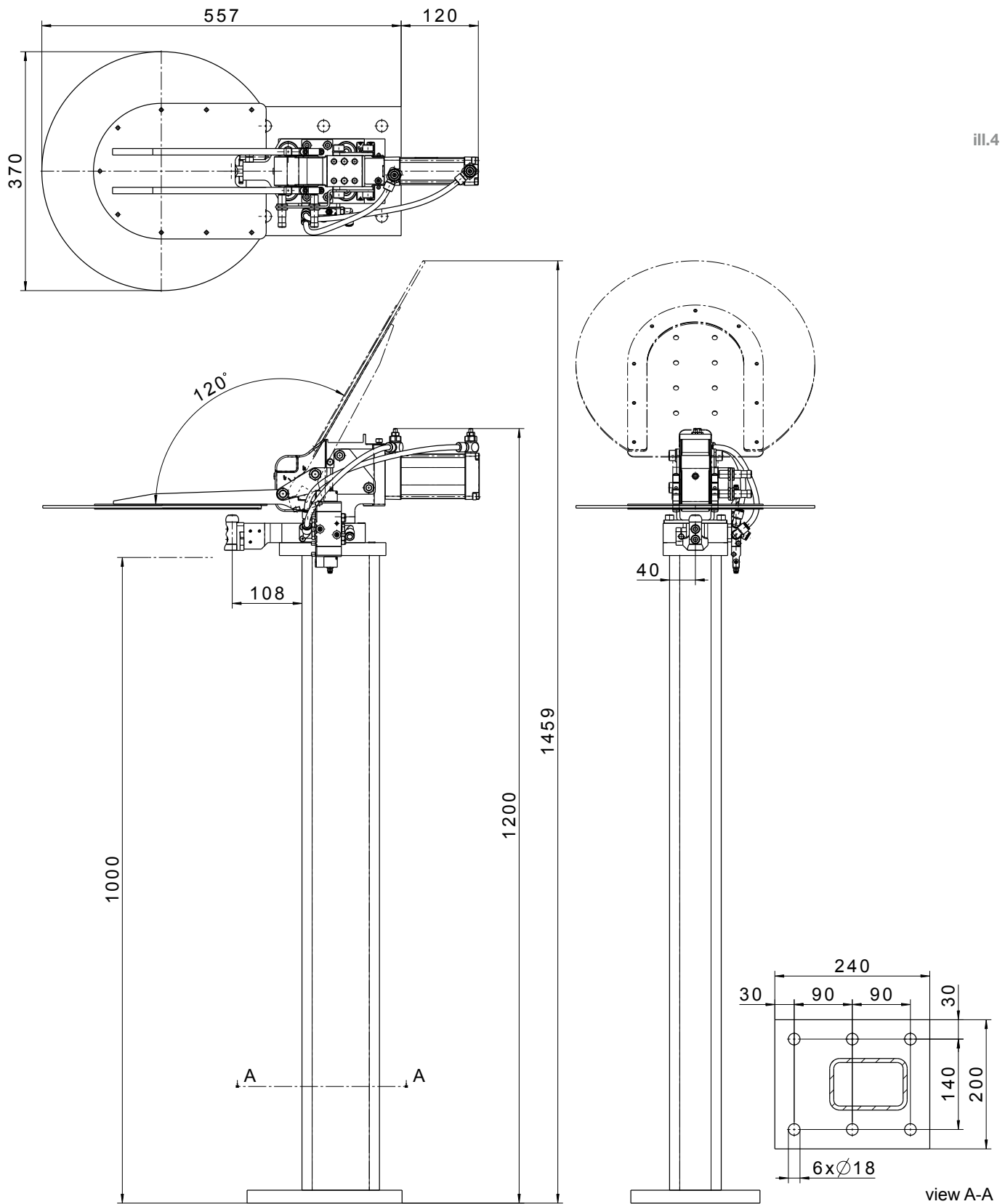

Tool stand base

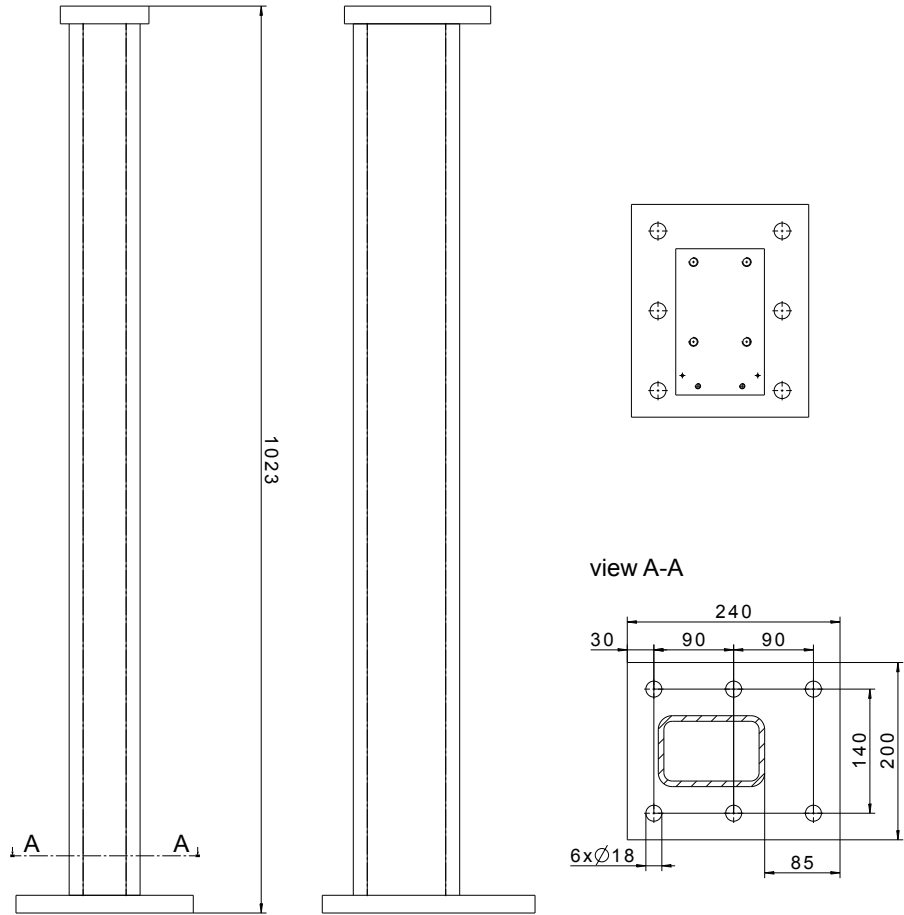

Order no	Description
K81904351	Tool stand base H = 1000 mm, RAL 9003

Positioning plate

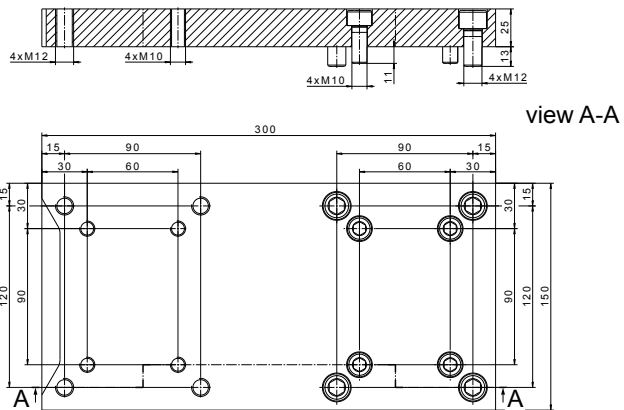

Order no	Description
K81565881	Positioning plate for expanding the storage options, includes mounting materials

MPS 080/130 TOOL STAND

Tool stand upper part



Order no.	Description	Sensors/ connection
K86500907	Tool stand upper part, includes mounting materials	1x PNP/ 1x M12
K86500916		1x NPN/ 1x M12

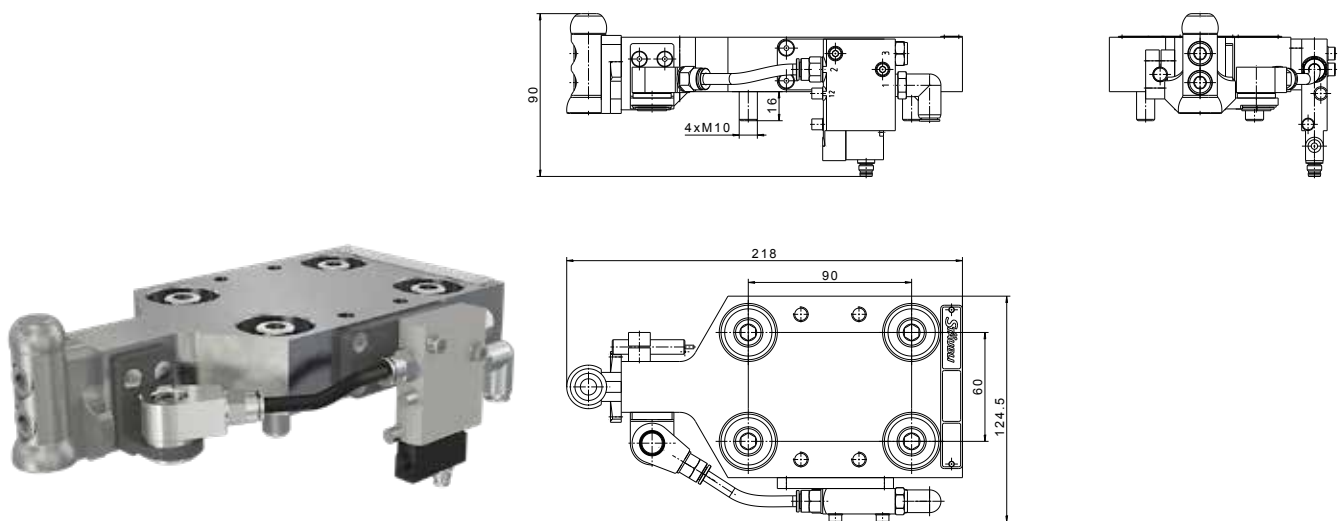

Order no.	Description	Compressed air connection	Sensors/ connection	Valve/ connection
K86500904	Tool stand upper part with Active Docking, includes mounting materials	1x Push-lock hose-Ø 6 mm	1x PNP/ 1x M12	1x M8 4-pole
K86500912			1x NPN/ 1x M12	1x M8 4-pole

Protective cover

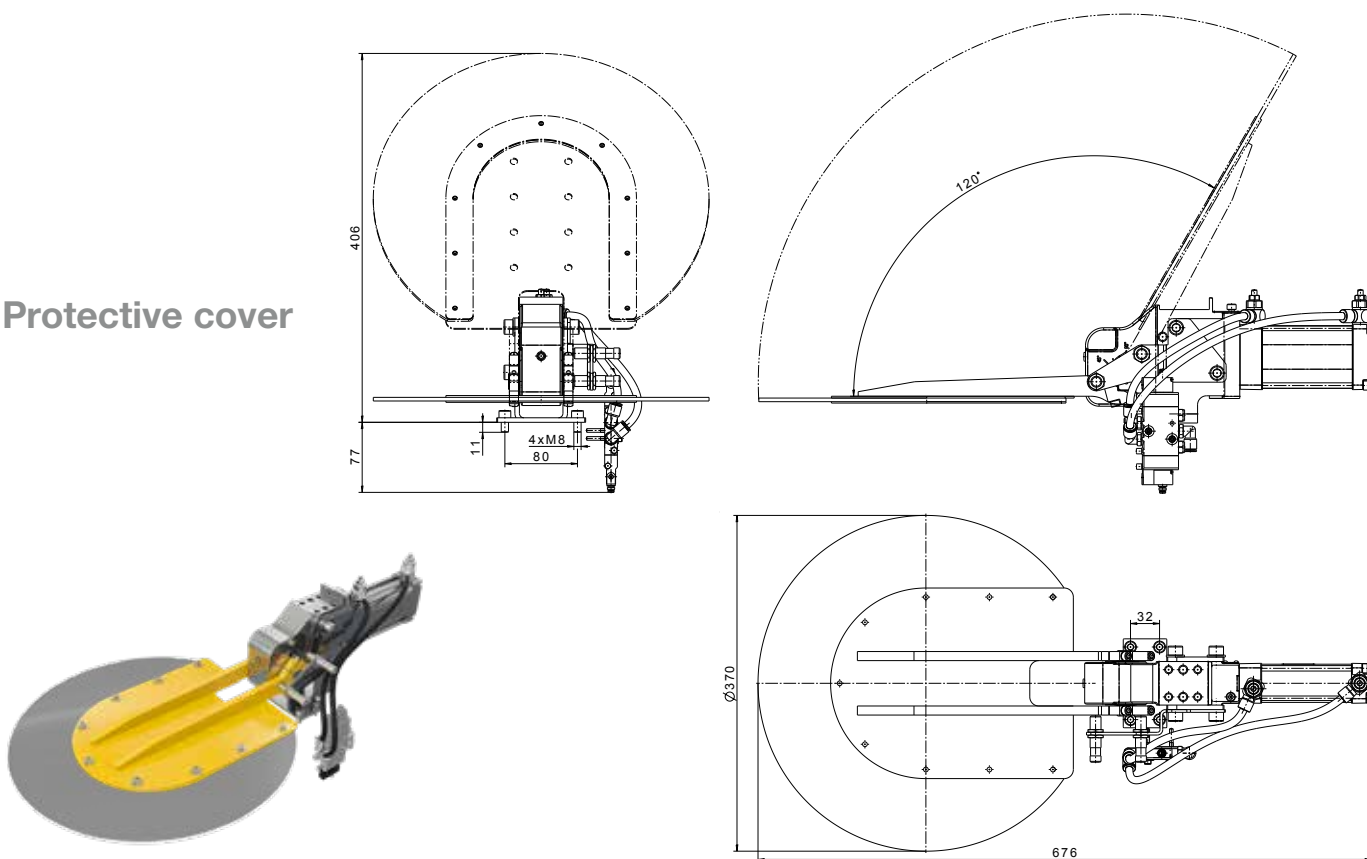

Order no.	Description	Compressed air connection	Sensors/ connection	Valve/ connection
K81562439	Protective cover for harsh working environments;	1x Push-lock hose-Ø 6 mm	PNP/ M12	2x M8 4-pole
K81562442	RAL 1004, includes mounting materials		NPN/ M12	2x M8 4-pole

Accessories

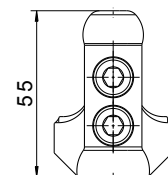
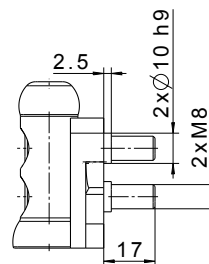
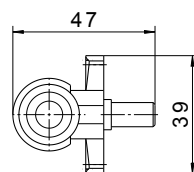

Order no.	Description
K81565636	Docking pin for self-assembly, includes mounting materials

MPS 260/1 IDA SAFETY

For handling and gripping applications
With IDA and Active Docking

R

T

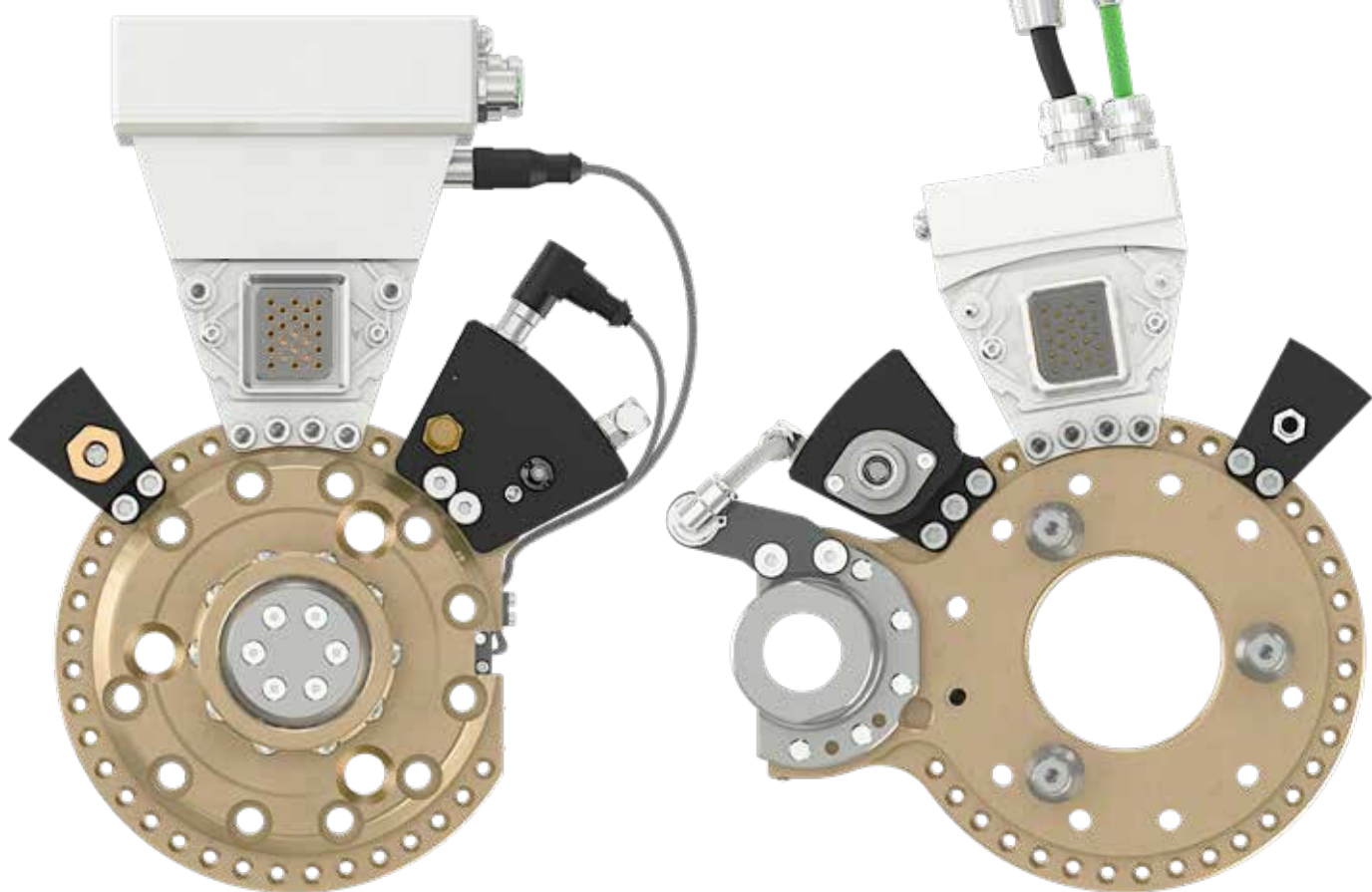

Application	Sensors	Connection transfer modules*		Order no.
		Pneumatic	Integrated bus module	
Gripping/ Handling	R PNP	1x G 1/8	M12-D coded 7/8 5-pole	MPS260RD-0000-0000-0000-0000-0000-00WB-IDAB
	T -			MPS260TC-0000-0000-0000-0000-0000-00WB-IDAB

Technical data for the base unit on the robot and tool sides can be found on page 68.
* Technical data for all transfer modules can be found from page 84 onwards.



Transfer modules with alternative thread and plug connections can be customized using our simple configuration system (see page 66).

R

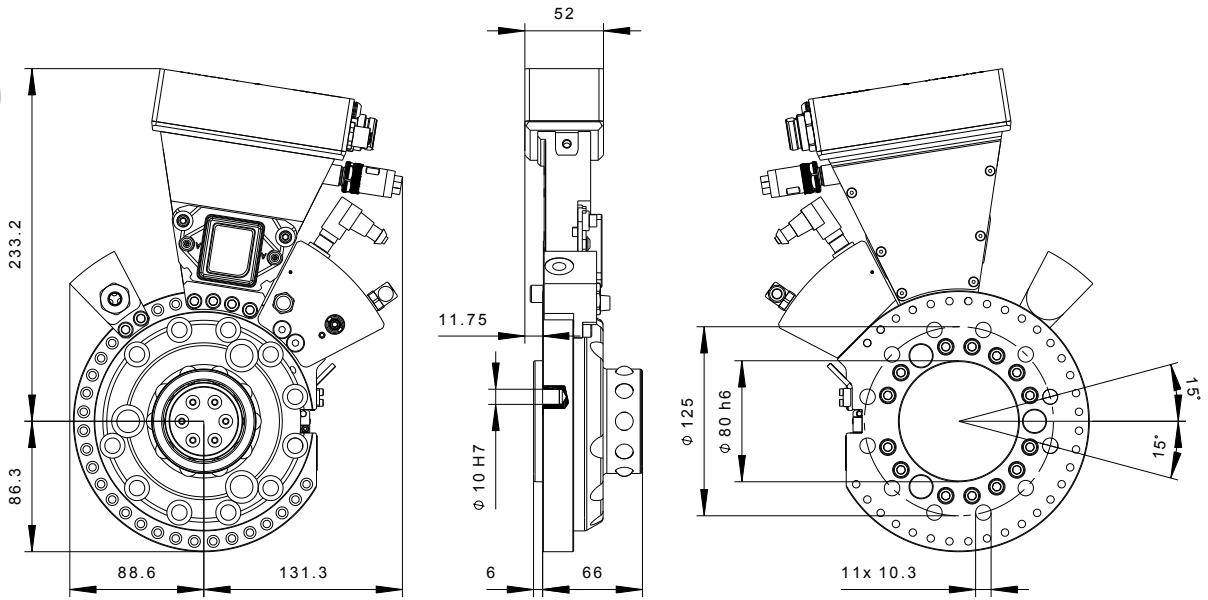

T

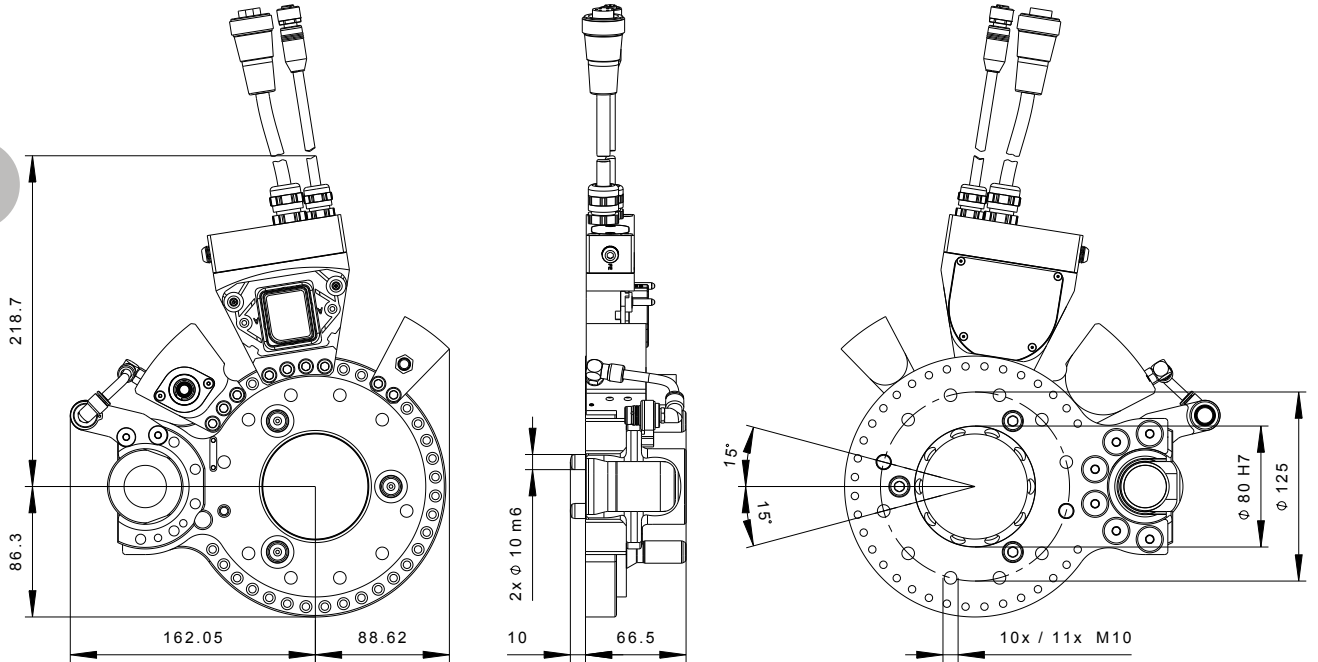

MPS 260 COMPLETE

MPS 260/2

For handling and gripping applications

R



T



Application	Sensors	Connection transfer modules*		Order no.
		Pneumatic	Signal	
Gripping/ Handling/ Vacuum	R PNP	1x G 1/8	KPTC2E18-32P	MPS260RC-0000-0000-0000-0000-00WB-ECAB
	R NPN			MPS260RG-0000-0000-0000-0000-00WB-ECAB
	T -		KPTC2E18-32S	MPS260TA-0000-0000-0000-0000-00WB-ECAB

Technical data for the base unit on the robot and tool sides can be found on page 68.

* Technical data for all transfer modules can be found from page 84 onwards.



Transfer modules with alternative thread and plug connections can be customized using our simple configuration system (see page 66).

R

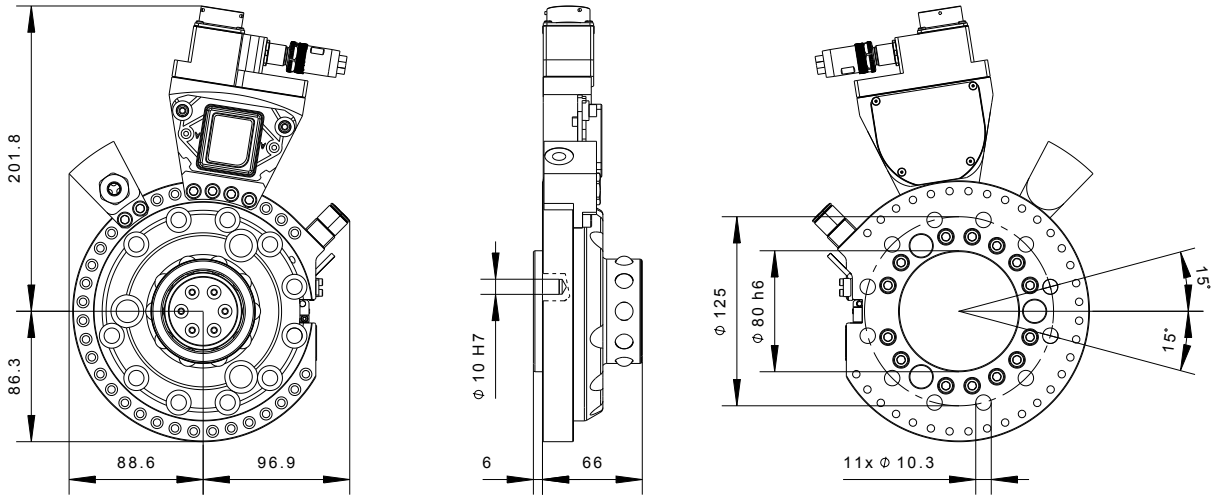

T

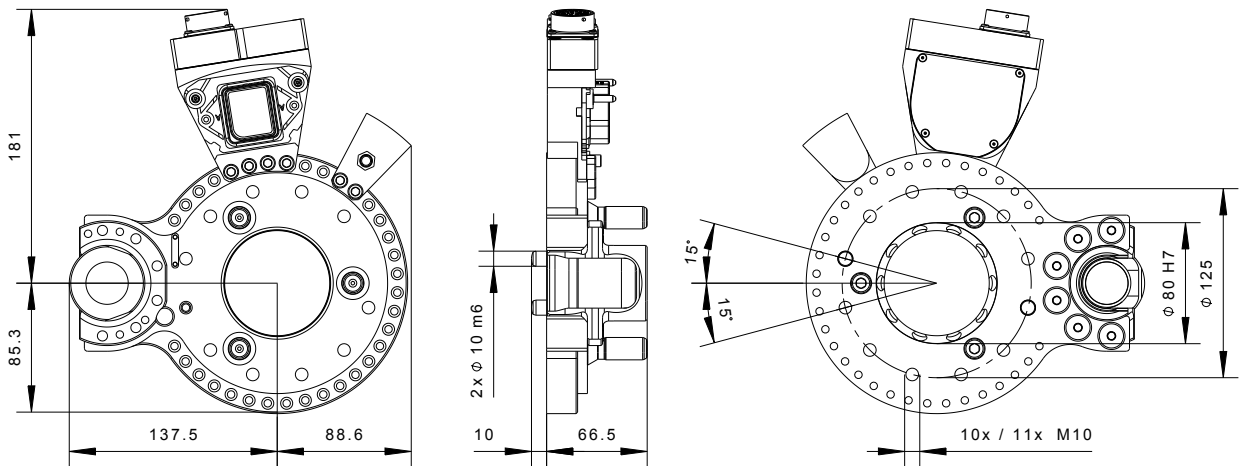

MPS 260 COMPLETE

MPS 260/3

For handling, gripping and vacuum applications



Application	Sensors	Connection transfer modules*		Order no.
		Pneumatic	Signal	
Gripping/ Handling/ Vacuum	R PNP	4x G 1/8	KPTC2E18-32P	MPS260RC-0000-0000-0000-0000-P4WP-ECAB
	R NPN			MPS260RG-0000-0000-0000-0000-P4WP-ECAB
	T -		KPTC2E18-32S	MPS260TA-0000-0000-0000-0000-P4WP-ECAB

Technical data for the base unit on the robot and tool sides can be found on page 68.
 * Technical data for all transfer modules can be found from page 84 onwards.



Transfer modules with alternative thread and plug connections can be customized using our simple configuration system (see page 66).

R

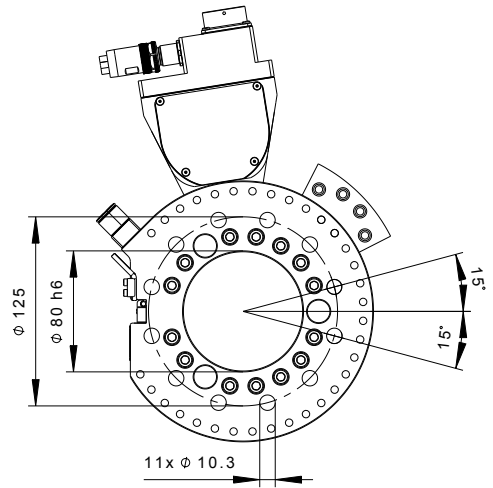
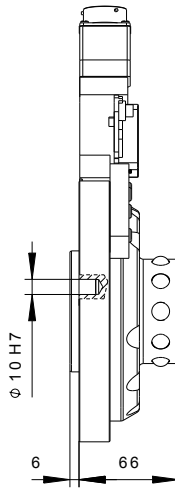
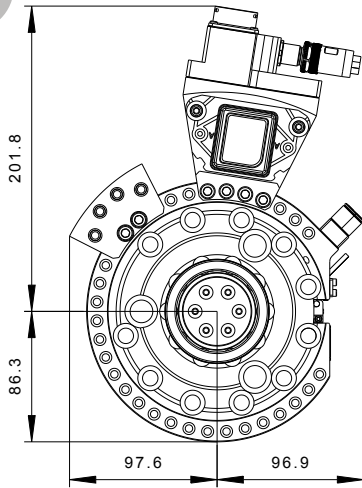

T

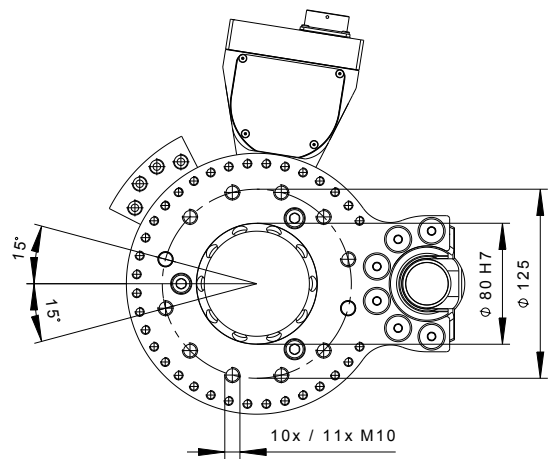
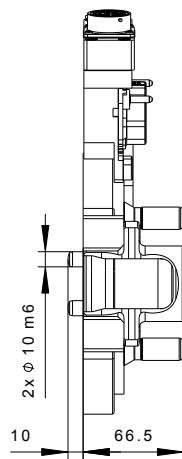
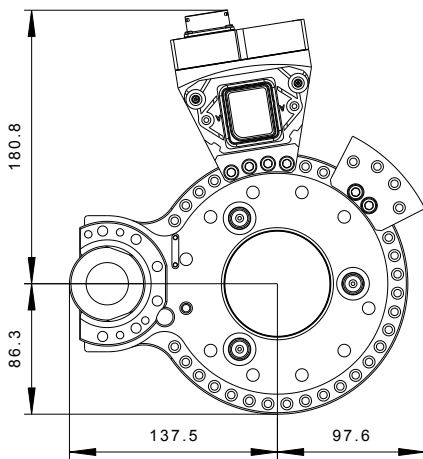

MPS 260 COMPLETE

MPS 260/4

For handling, gripping and vacuum applications

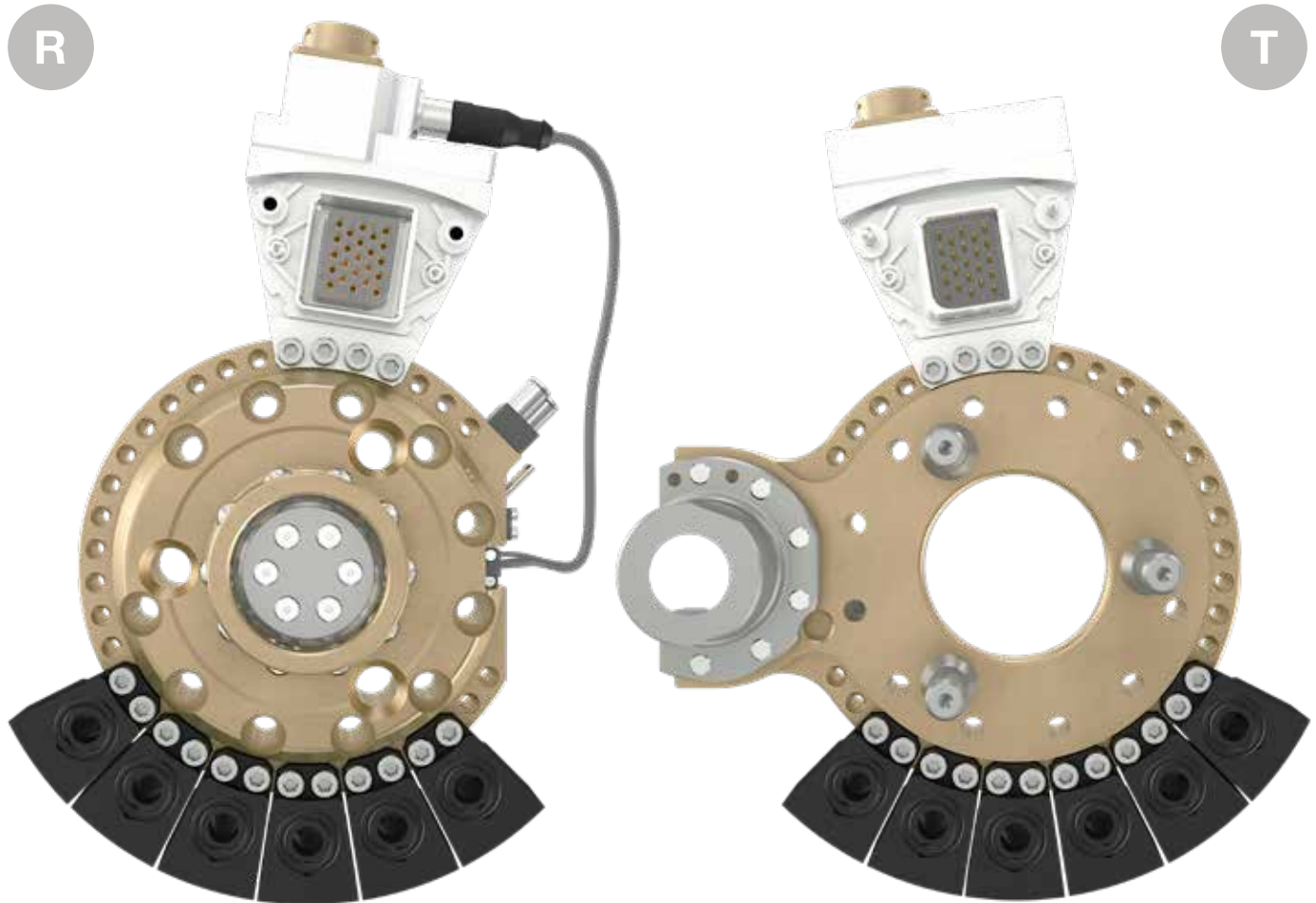

Application	Sensors	Connection transfer modules*		Order no.
		Pneumatic	Signal	
Gripping/ Handling/ Vacuum	R PNP	6x G 3/8	KPTC2E18-32P	MPS260RC-00WE-WEWE-WEWE-WE00-0000-0000-ECAB
	R NPN			MPS260RG-00WE-WEWE-WEWE-WE00-0000-0000-ECAB
	T -		KPTC2E18-32S	MPS260TA-00WE-WEWE-WEWE-WE00-0000-0000-ECAB

Technical data for the base unit on the robot and tool sides can be found on page 68.

* Technical data for all transfer modules can be found from page 84 onwards.



Transfer modules with alternative thread and plug connections can be customized using our simple configuration system (see page 66).

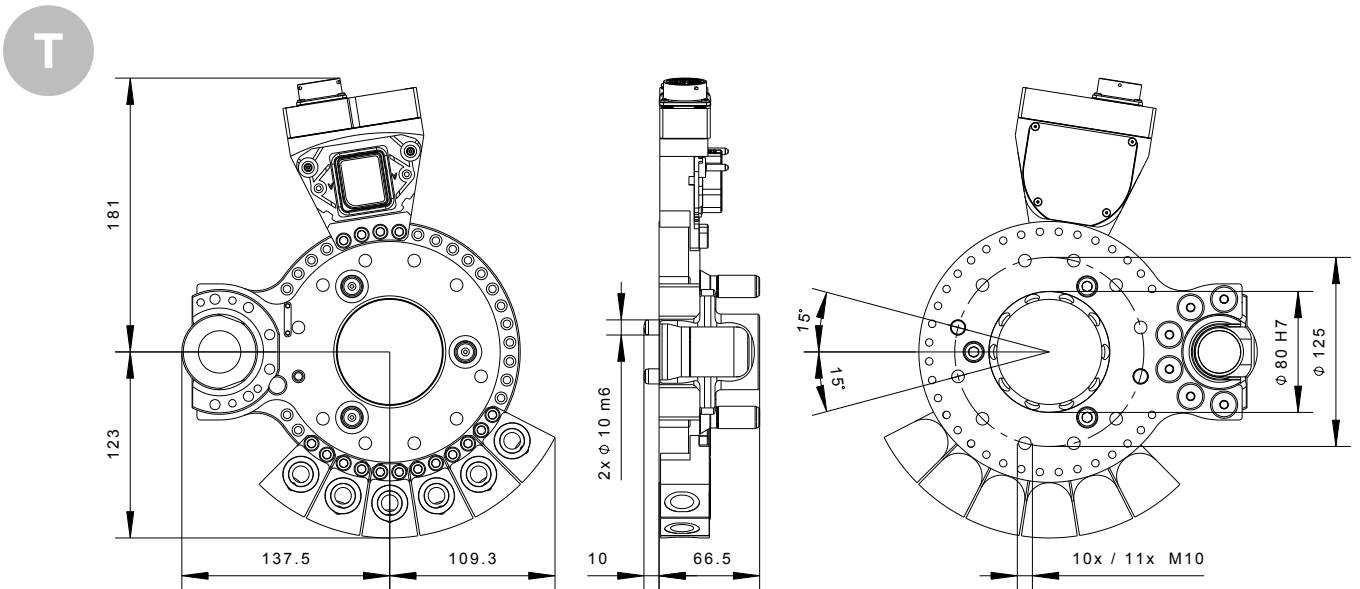
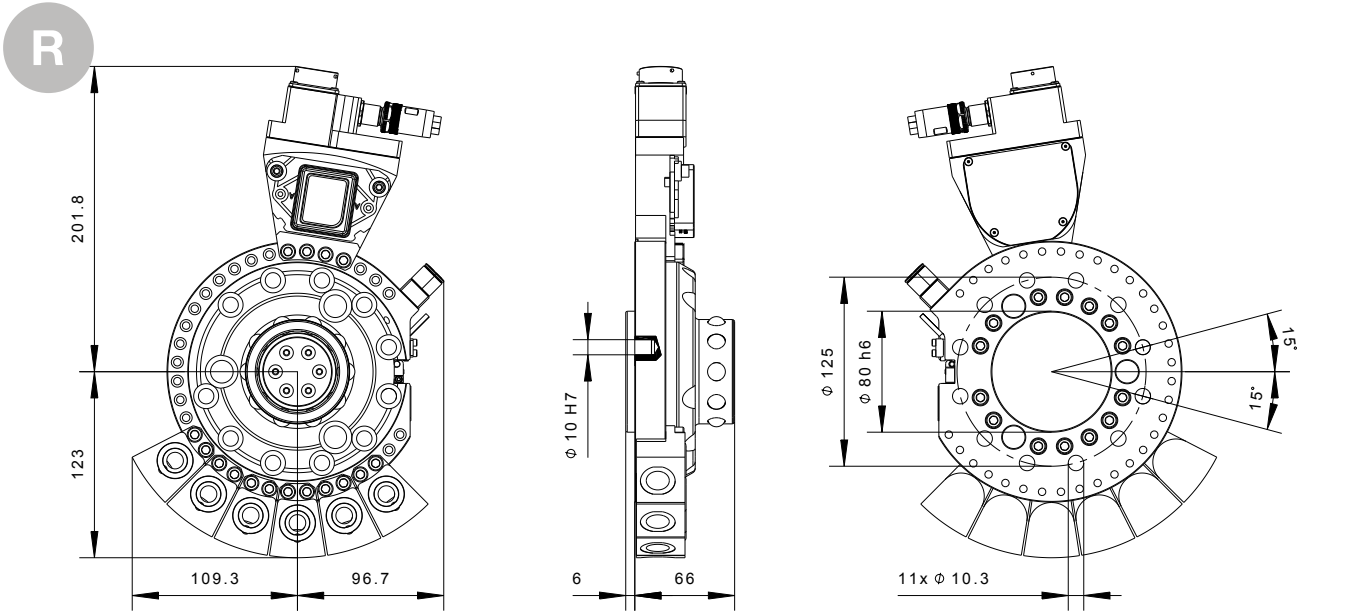

MPS 260 COMPLETE

MPS 260/5

For handling, gripping and welding applications

R



T



T



Application	Sensors	Connection transfer modules*					
		Pneumatic	Signal	Fluids	Servo	Primary circuit	
Welding/ gripping	R PNP	2x G 1/8	KPTC2E18-32P	2x G 3/8	B EG A 120 MR 11 00 0200 400	3x M25	
	R NPN					3x M25	
Welding	T -		KPTC2E18-32S	-	-	B DF A 108 FR 05 00 0150 000	3x M25
Gripping	T -					-	-

Technical data for the base unit on the robot and tool sides can be found on page 68.

* Technical data for all transfer modules can be found from page 84 onwards.

Application	Sensors	Order no.
Welding/ gripping	R PNP	MPS260RC-00WB-WBWA-WA00-0000-WPAB-ECAC-ECAB
	R NPN	MPS260RG-00WB-WBWA-WA00-0000-WPAB-ECAC-ECAB
Welding	T -	MPS260TA-00WB-WBWA-WA00-0000-WPAB-ECAC-ECAB
Gripping	T -	MPS260TA-00WB-WB00-0000-0000-0000-0000-ECAB



Transfer modules with alternative thread and plug connections can be customized using our simple configuration system (see page 66).

R

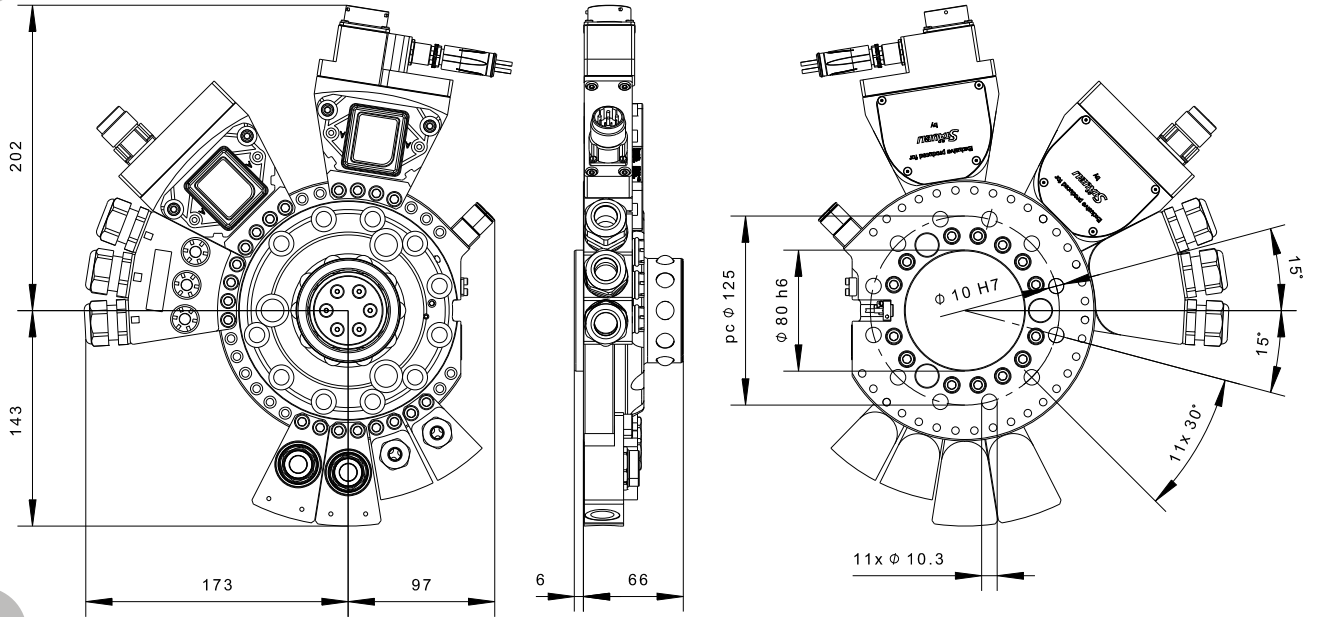

T

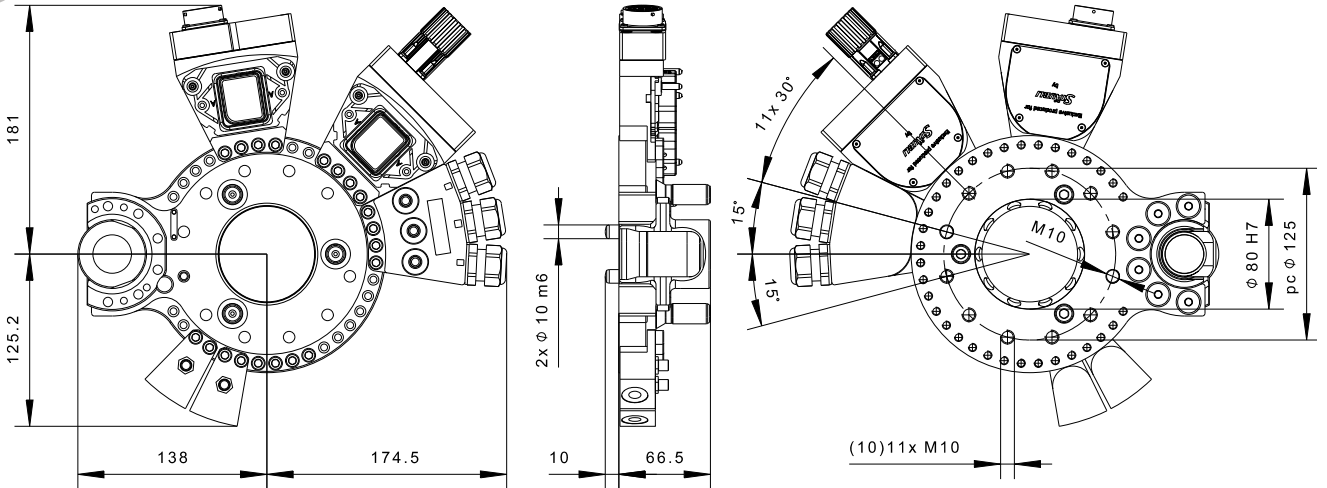

T

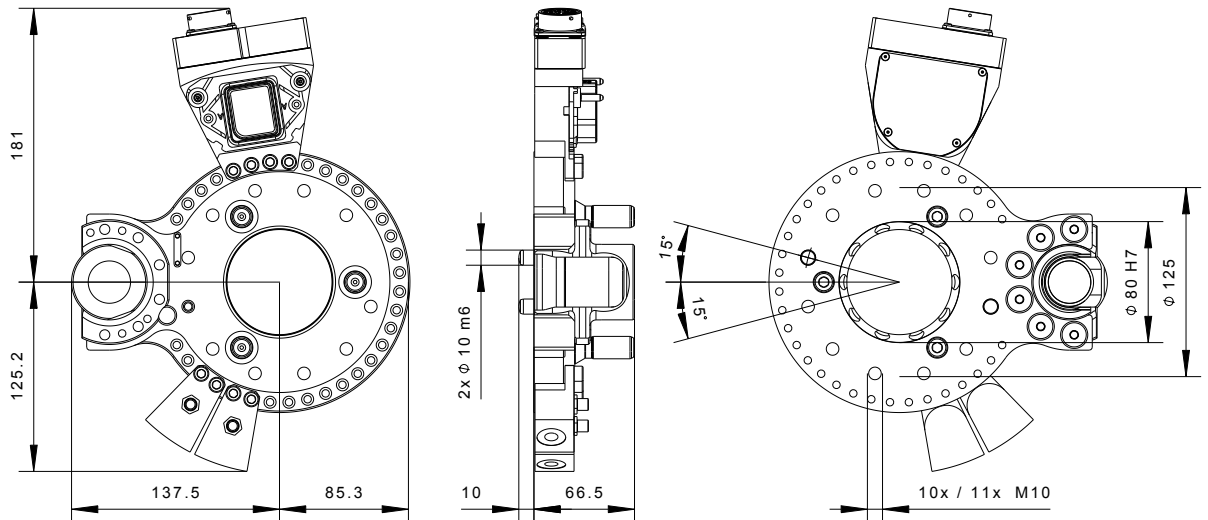

MPS 260 MODULAR

4 easy steps to your modular solution

Take advantage of Stäubli's modular product concept for maximum design freedom.
Configure your perfect tool changing system in just 4 easy steps.



R

1 Choose your **base unit** (page 68) and note the module order code.

2 Choose your **transfer modules** (from page 84 onwards). Position the modules on the mounting holes 1 to 24 by entering the module order code. The mounting holes 25 and 26 cannot be used for technical reasons. IDAB, ECAB, ECAE, ECAI and ECAL must be mounted in hole positions 27 to 30. All modules starting with "EC" cannot be mounted at module space 1-4.

M P S 2 6 0 R D - 0 0 W A - W B 0 0 - P 4 W P - W E 0 0 - W P A B - E C A C - E C A B

1 2 3 4 5 6 7 8 9 10 11 12 13 14 15 16 17 18 19 20 21 22 23 24 27 28 29 30

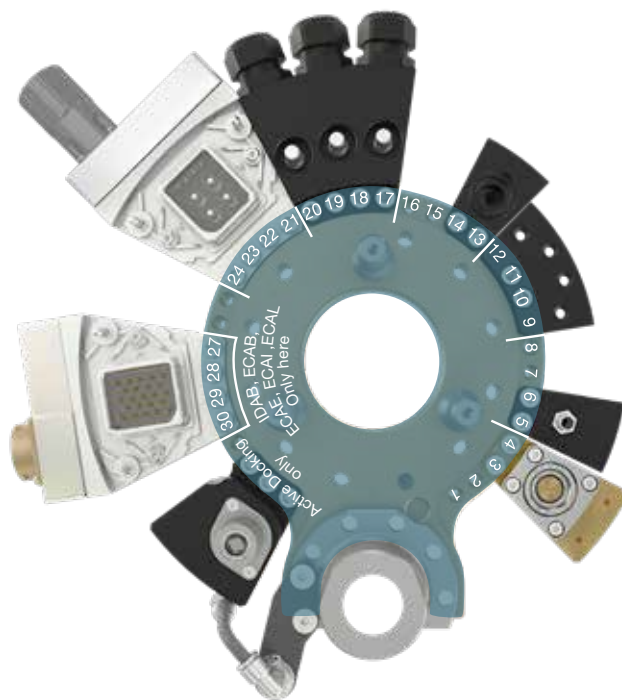

T

3 Select the appropriate **base unit** for your tool side (from page 70).
 Transfer the module order codes of the **transfer modules** corresponding to the robot side.

M P S 2 6 0 T C - 0 0 W A - W B 0 0 - P 4 W P - W E 0 0 - W P A B - E C A C - E C A B

1 2 3 4 5 6 7 8 9 10 11 12 13 14 15 16 17 18 19 20 21 22 23 24 27 28 29 30



T

4 **Reduce your investment** by varying your tool side and removing any transfer modules that aren't needed on the tool side (Replace module order code with 00 or 0000).

M P S 2 6 0 T C - 0 0 W A - 0 0 0 0 - 0 0 0 0 - W E 0 0 - 0 0 0 0 - E C A C - E C A B

1 2 3 4 5 6 7 8 9 10 11 12 13 14 15 16 17 18 19 20 21 22 23 24 27 28 29 30

MPS 260 MODULAR

MPS 260 base unit robot side

MPS260RA/RE

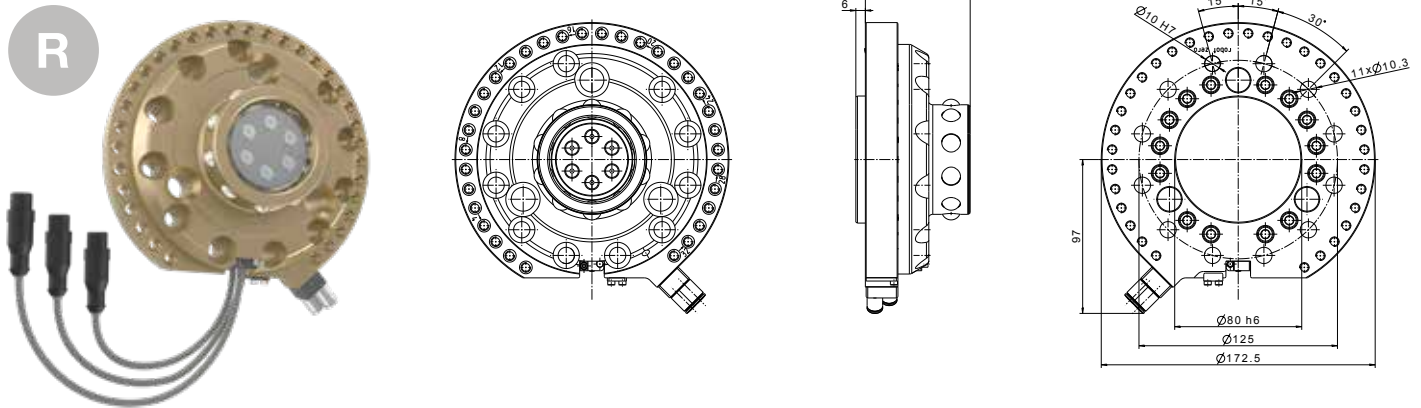

MPS260RB/RF

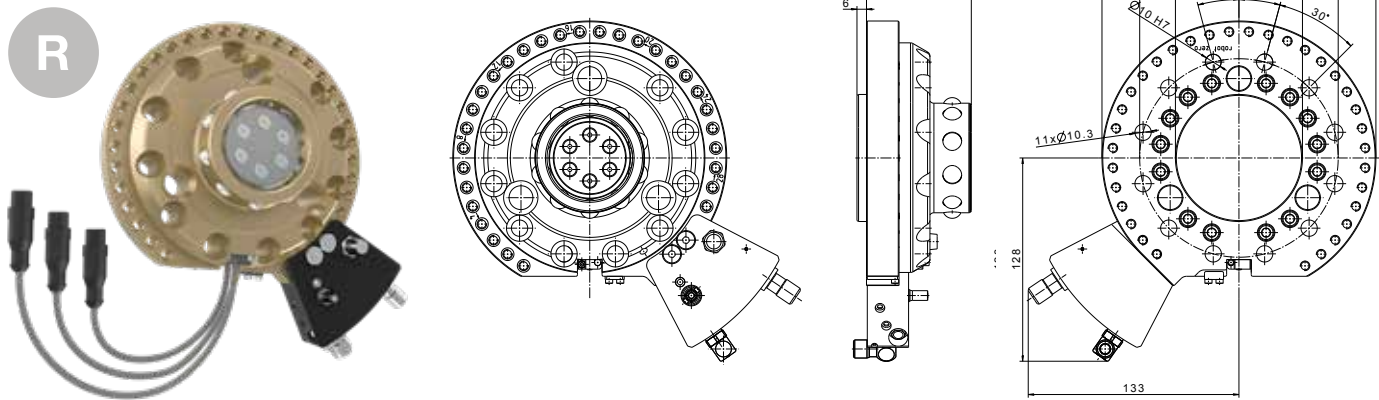

	Order no.	Pitch circle diameter (PCD)	Bending moment	Torsional moment	Payload	Compressed air connection	Safety module	Sensors/ connection	Module order code
R	K81557717	Ø 125 mm	2000 Nm	2000 Nm	350 kg	Push-lock-hose-Ø 6 mm	-	3x PNP/ 3x M12	MPS260RA
	3x NPN/ 3x M12							MPS260RE	
R	K81557718	Ø 125 mm	2000 Nm	2000 Nm	350 kg	Push-lock-hose-Ø 6 mm	Pressure switch PNP/ NPN 1x M12	3x PNP/ 3x M12	MPS260RB
	3x NPN/ 3x M12							MPS260RF	

MPS260RC/RG

R

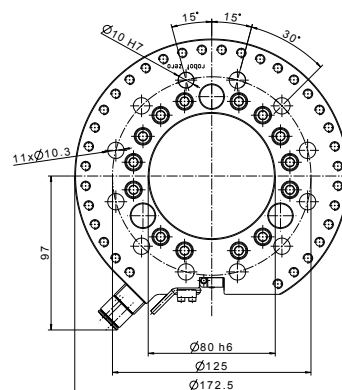
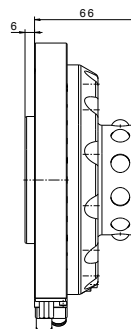
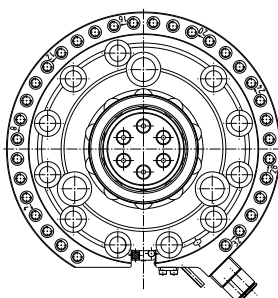

MPS260RD/RH

R

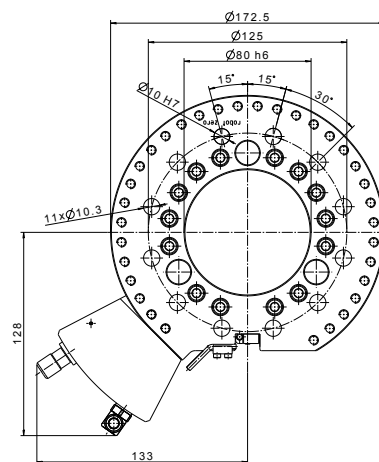
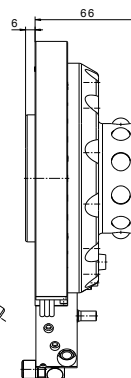
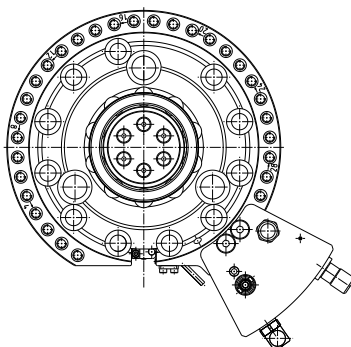

	Order no.	Pitch circle diameter (PCD)	Bending moment	Torsional moment	Payload	Compressed air connection	Safety module	Sensors/ connection	Module order code
R	K81557719	Ø 125 mm	2000 Nm	2000 Nm	350 kg	Push-lock-hose-Ø 6 mm	-	3x PNP/ 1x M12 8-pole	MPS260RC
	K81557738							3x NPN/ 1x M12 8-pole	MPS260RG
R	K81557720	Ø 125 mm	2000 Nm	2000 Nm	350 kg	Push-lock-hose-Ø 6 mm	Pressure switch PNP/ NPN 1x M12	3x PNP/ 1x M12 8-pole	MPS260RD
	K81557744							3x NPN/ 1x M12 8-pole	MPS260RH

MPS 260 MODULAR

MPS 260 base unit tool side - 2000 Nm

MPS260TO

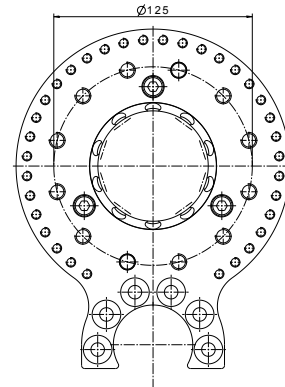
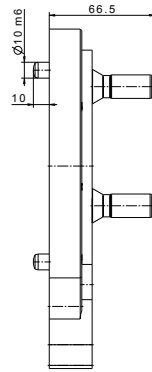
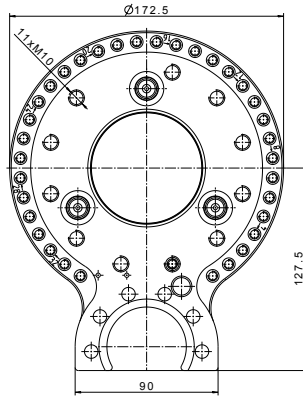

MPS260TB

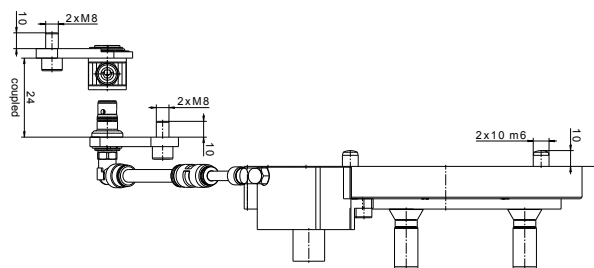
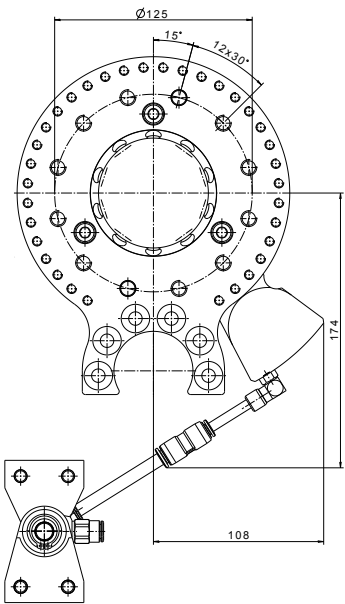
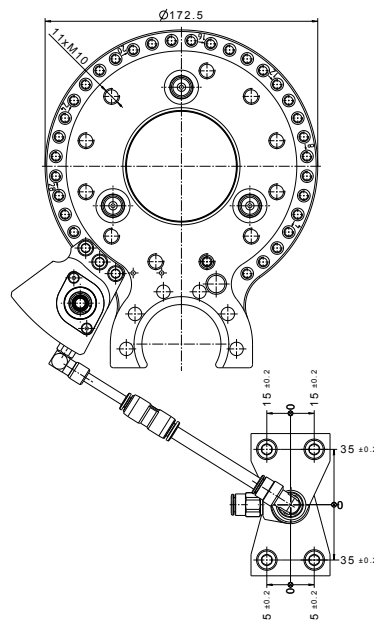

MPS260TA

T

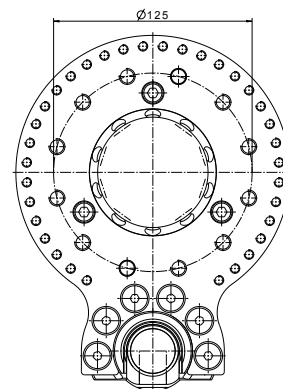
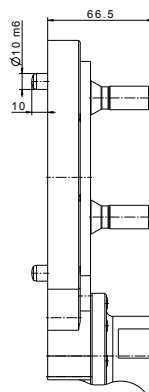
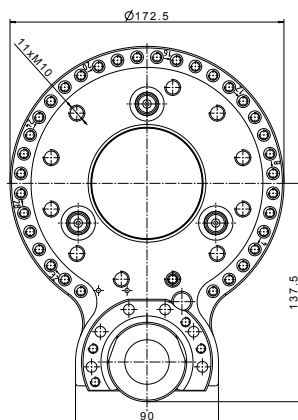

MPS260TC

T

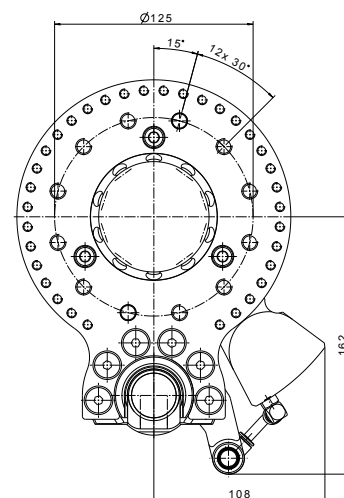
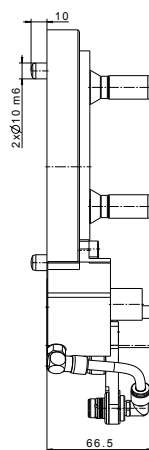
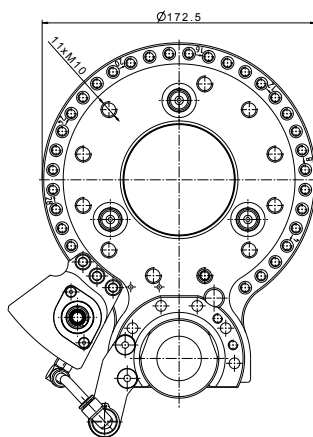

	Order no.	Pitch circle diameter (PCD)	Bending moment	Torsional moment	Docking hook	Safety module	Module order code
T	K81557665	Ø 125 mm	2000 Nm	2000 Nm	no	no	MPS260TO
T	K81557669	Ø 125 mm	2000 Nm	2000 Nm	no	yes	MPS260TB
T	K81557662	Ø 125 mm	2000 Nm	2000 Nm	yes	no	MPS260TA
T	K81557670	Ø 125 mm	2000 Nm	2000 Nm	yes	yes	MPS260TC

MPS 260 MODULAR

MPS 260S base unit tool side - 2500 Nm

MPS260TD

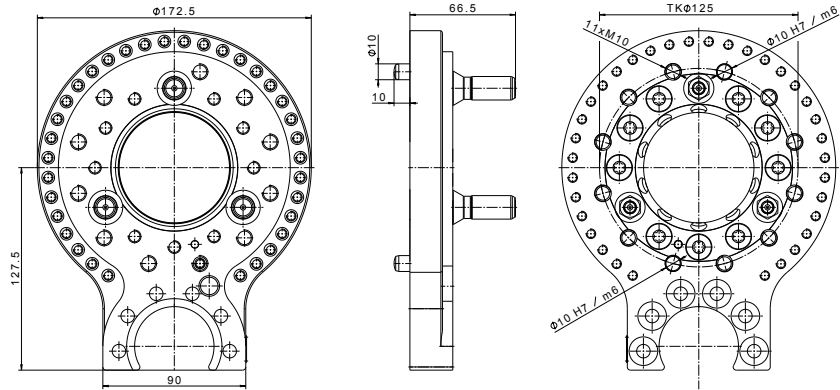

MPS260TE

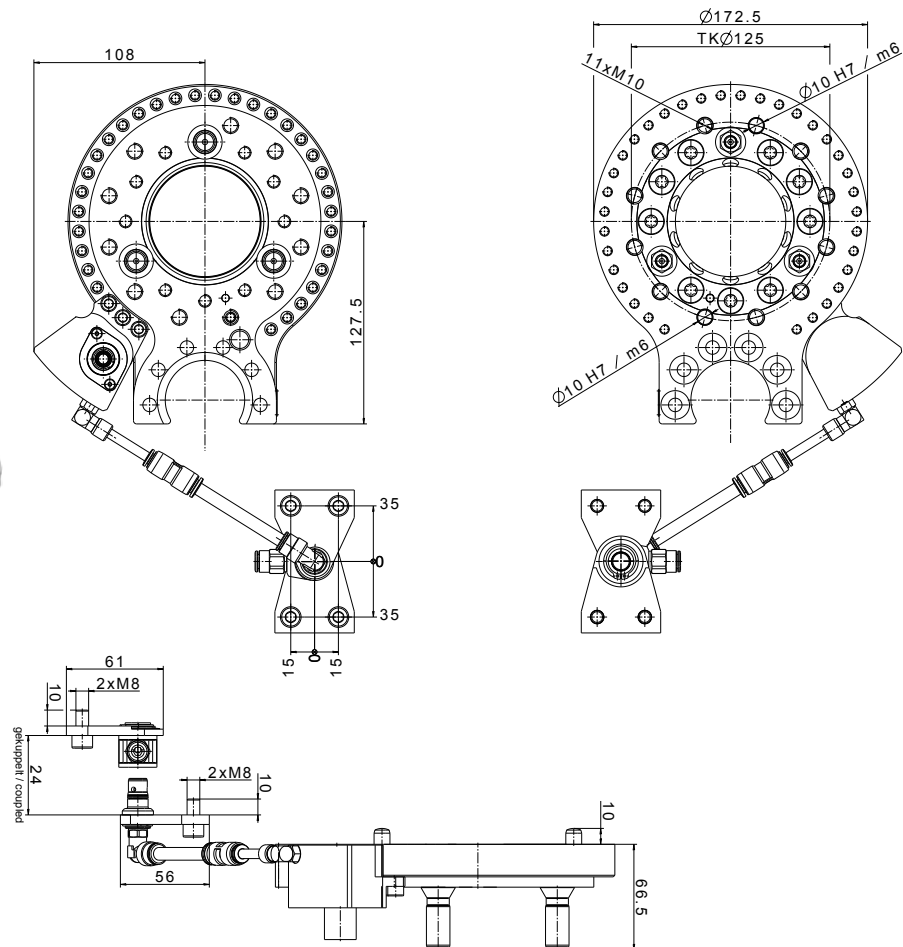

MPS260TF

T

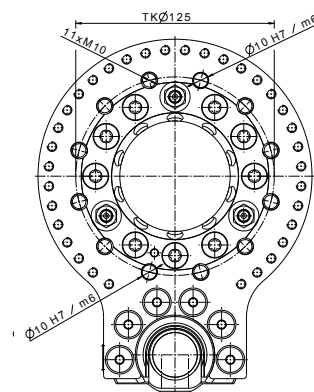
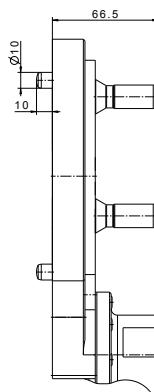
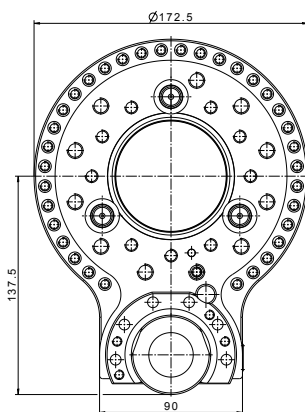

MPS260TG

T

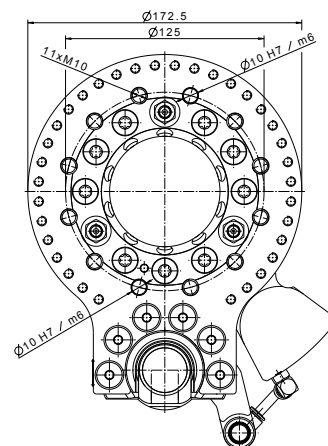
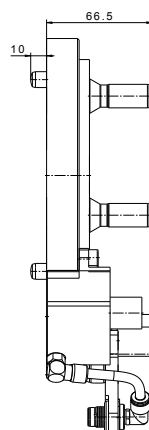
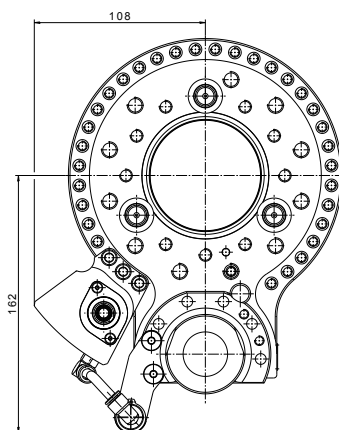

	Order no.	Pitch circle diameter (PCD)	Bending moment	Torsional moment	Docking hook	Safety module	Module order code
T	K81557674	Ø 125 mm	2500 Nm	2500 Nm	no	no	MPS260TD
T	K81557675	Ø 125 mm	2500 Nm	2500 Nm	no	yes	MPS260TE
T	K81557676	Ø 125 mm	2500 Nm	2500 Nm	yes	no	MPS260TF
T	K81557677	Ø 125 mm	2500 Nm	2500 Nm	yes	yes	MPS260TG

MPS 260 Robot adapter flange

R

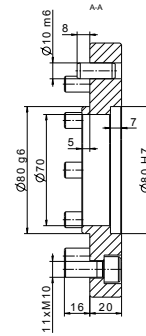
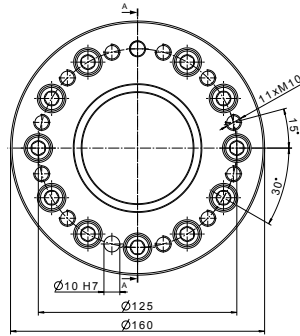

ill.1

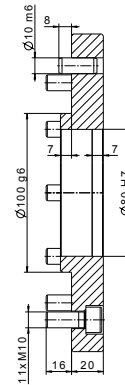
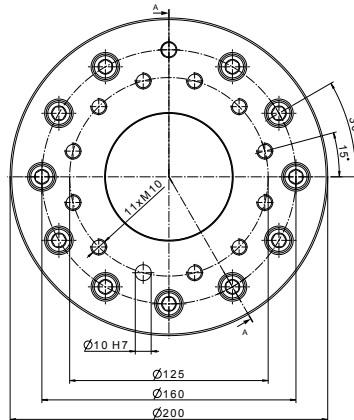

ill.2

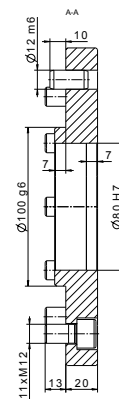
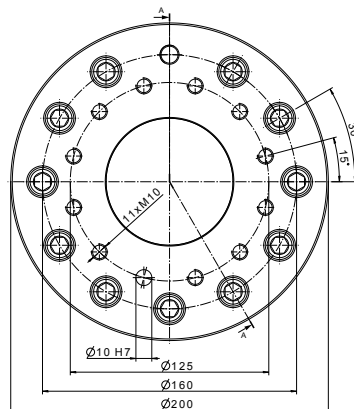

ill.3

	ill.	Order no.*	Adaption to	Zero offset
R	1	K81558258	ISO 9409-1-125-11-M10	0°
R	2	K81558259	ISO 9409-1-160-11-M10	15°
R	3	K81558260	ISO 9409-1-160-11-M12	15°

* including mounting material.

MPS 260 Accessories

Robot side mounting kit



Order no.	Pitch diameter	Mounting materials	Strength class*	Locating pin
K81560779	Ø 125 mm	(11x) M10x40	12.9	(1x) 10/24

* The specifications of the robot manufacturers must be observed. If the specifications are different, use the corresponding strength classes.

Emergency release



Order no.	Description
K81558229	Tool for emergency release

Teaching aid



Order no.	Description
K81557699	Teaching aid for the robot tool change system
K81557692	Storage case including teaching aid for the robot tool change system

MPS 260 – Tool stand

Flexibility and efficiency due to integrated tool stand

The tool stand is consistent with Stäubli’s modular tool changer concept. Its individual components are designed to provide maximum scope for flexibility.

- Flexibility: the separate system components allow you to compile your own individual storage solutions.
- Optimisation: the complete systems are already dimensioned and calibrated for tool weights.
- Performance Level d, Category 3-compliant: the optional Active Docking System with self-contained compressed air circuit ensures that tool locking and unlocking can only take place at the tool stand.
- Longevity: the floating bearing of the docking pin holds the tool in the vertical storage position and minimises the load on the components.
- Function protection: a protective cover prevents any particles from getting into the transfer module couplings and connectors.



Contact us for individual solutions or special versions such as tool stand systems for two tools.

Tool stand base	Positioning plate	Tool stand upper part	Protective cover	Sensors/ connection	Valve/ connection	Order no.	ill.
H = 1000 mm	with	without Active Docking	without	1x PNP/ 1x M12	without	K82800004	1
				1x NPN/ 1x M12	without	K82800005	-
			with	3x PNP/ 3x M12	2x M8 4-pole	K82800006	2
				3x NPN/ 3x M12	2x M8 4-pole	K82800007	-
H = 1000 mm	with	with Active Docking	without	1x PNP/ 1x M12	1x M8 4-pole	K82800008	-
				1x NPN/ 1x M12	1x M8 4-pole	K82800009	-
			with	3x PNP/ 3x M12	3x M8 4-pole	K82800010	-
				3x NPN/ 3x M12	3x M8 4-pole	K82800011	-
H = 1000 mm	without	without Active Docking	without	1x PNP/ 1x M12	without	K82800012	3
				1x NPN/ 1x M12	without	K82800013	-
			with	3x PNP/ 3x M12	2x M8 4-pole	K82800014	4
				3x NPN/ 3x M12	2x M8 4-pole	K82800015	-
H = 1000 mm	without	with Active Docking	without	1x PNP/ 1x M12	1x M8 4-pole	K82800016	-
				1x NPN/ 1x M12	1x M8 4-pole	K82800017	-
			with	3x PNP/ 3x M12	3x M8 4-pole	K82800018	-
				3x NPN/ 3x M12	3x M8 4-pole	K82800019	-

Technical data for all the single components can be found on page 81.

MPS 260 TOOL STAND

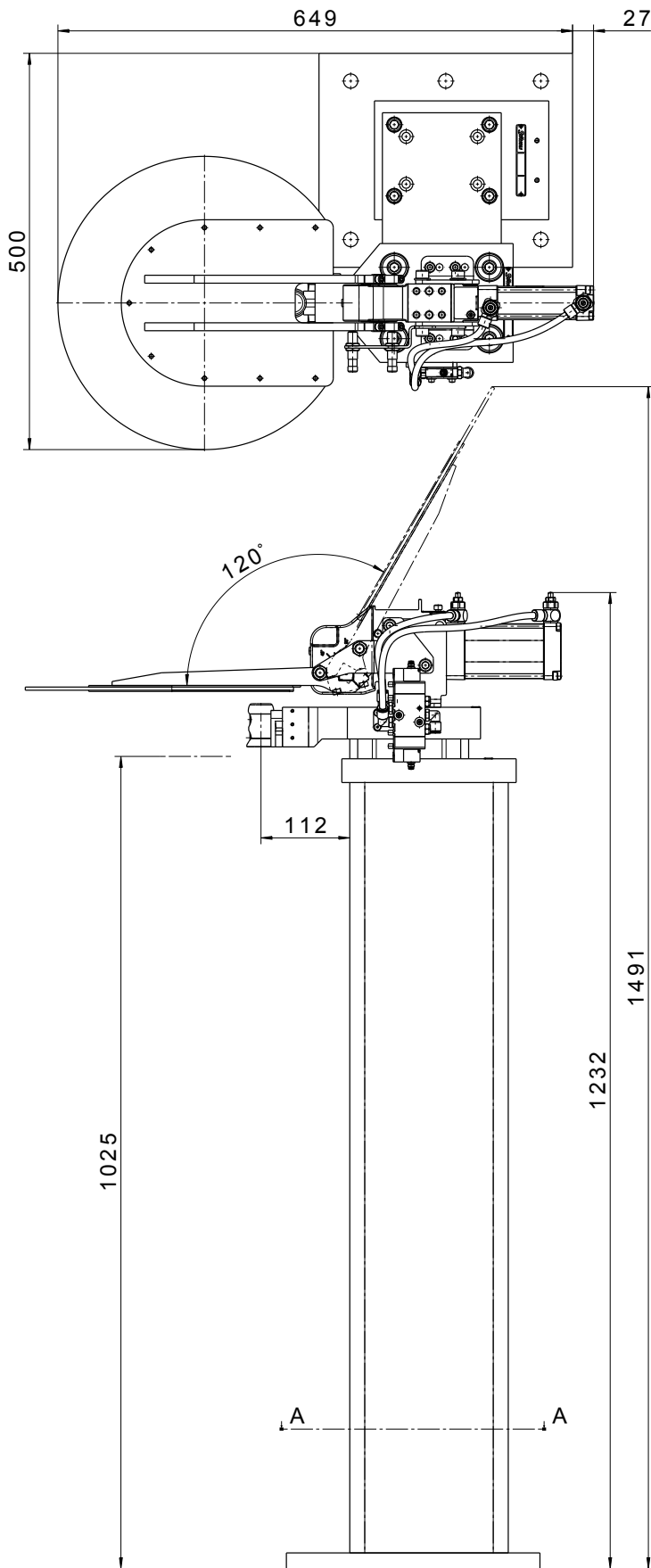

iii.2

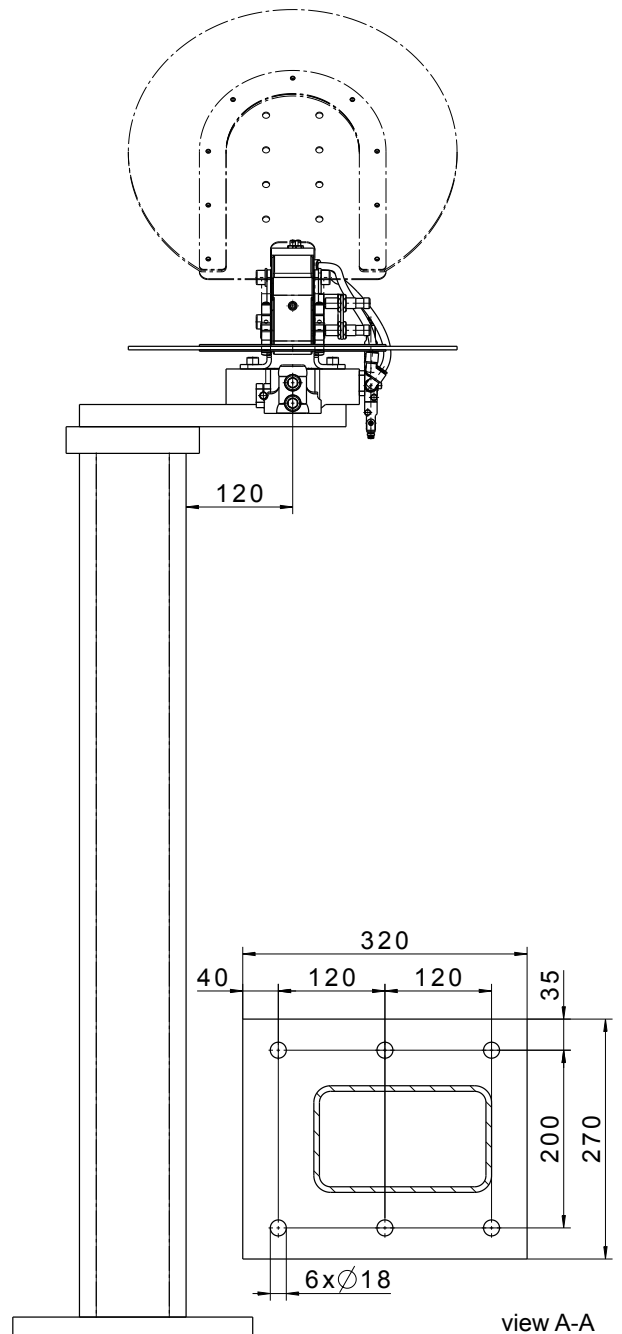

iii.3

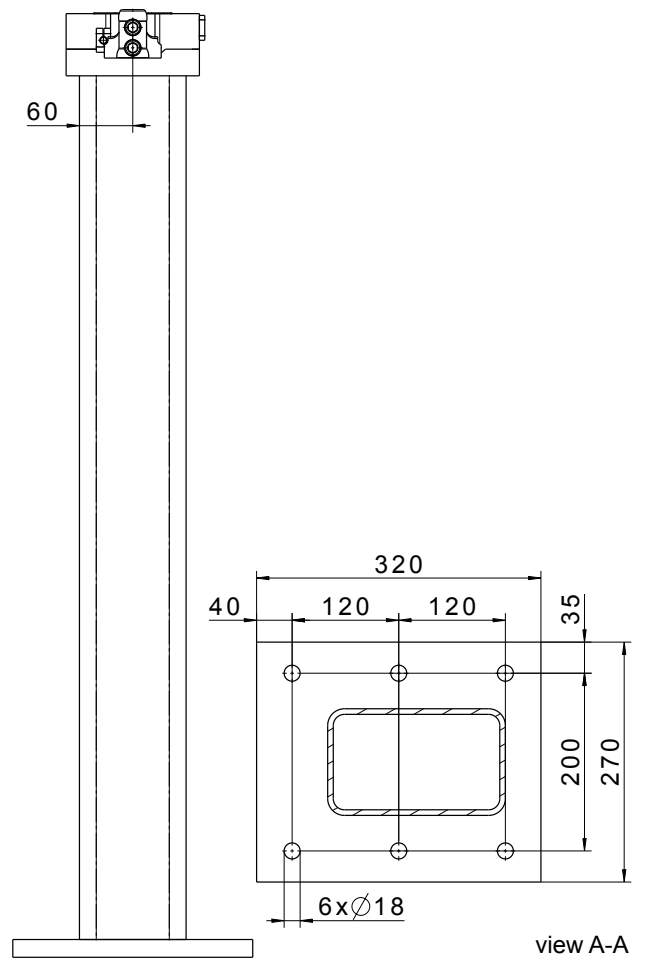
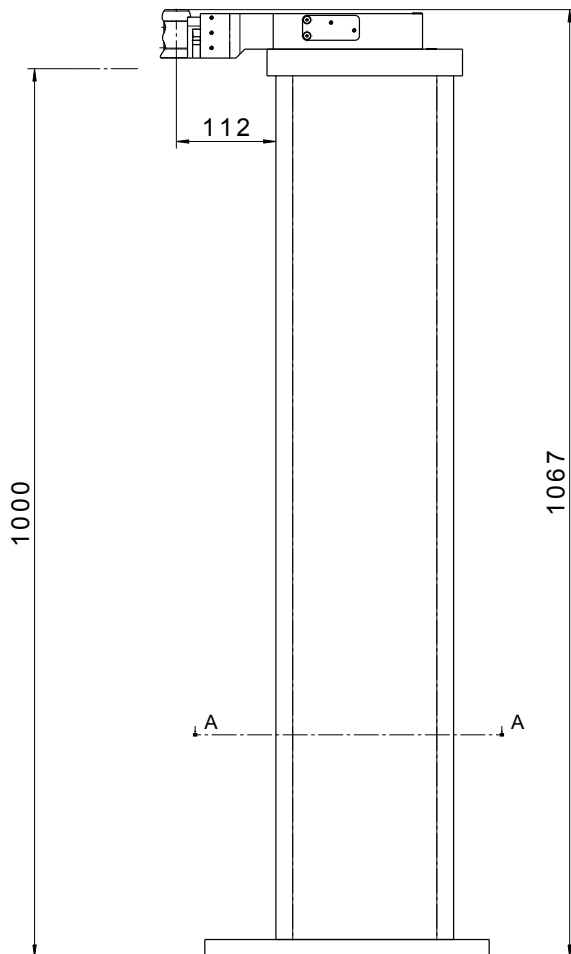
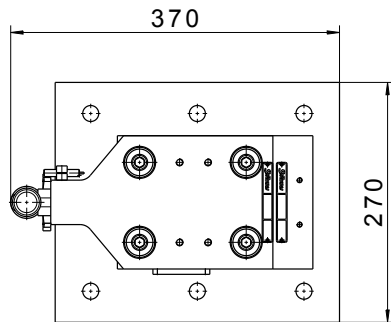

MPS 260 TOOL STAND

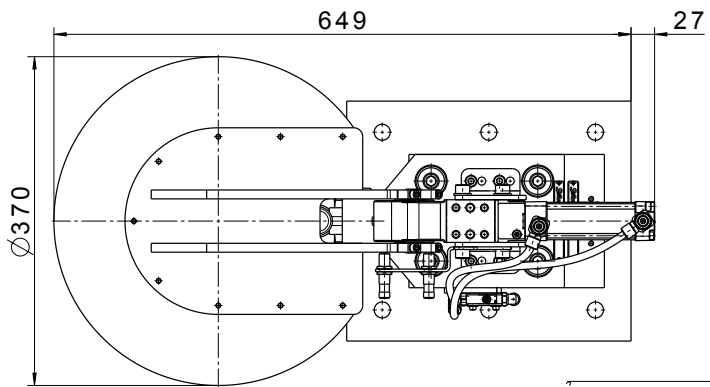

iii.4

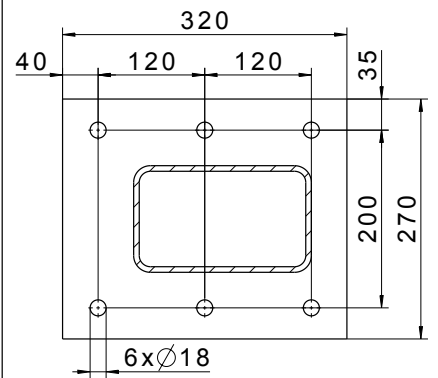
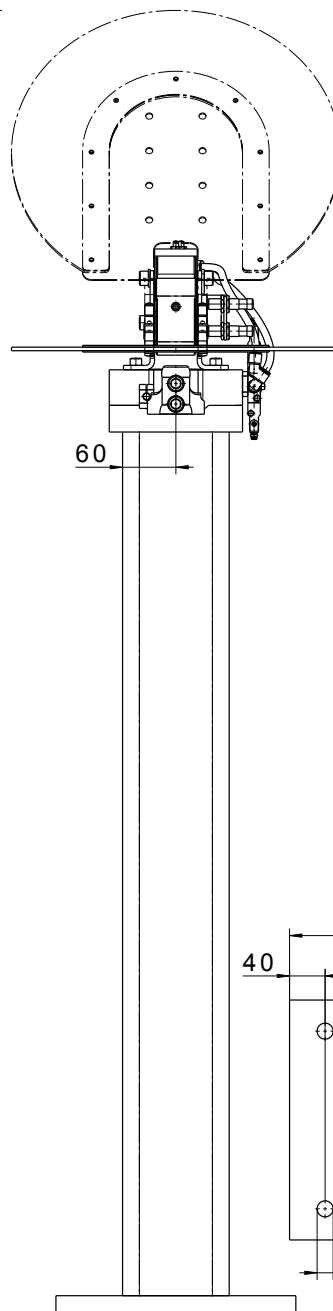
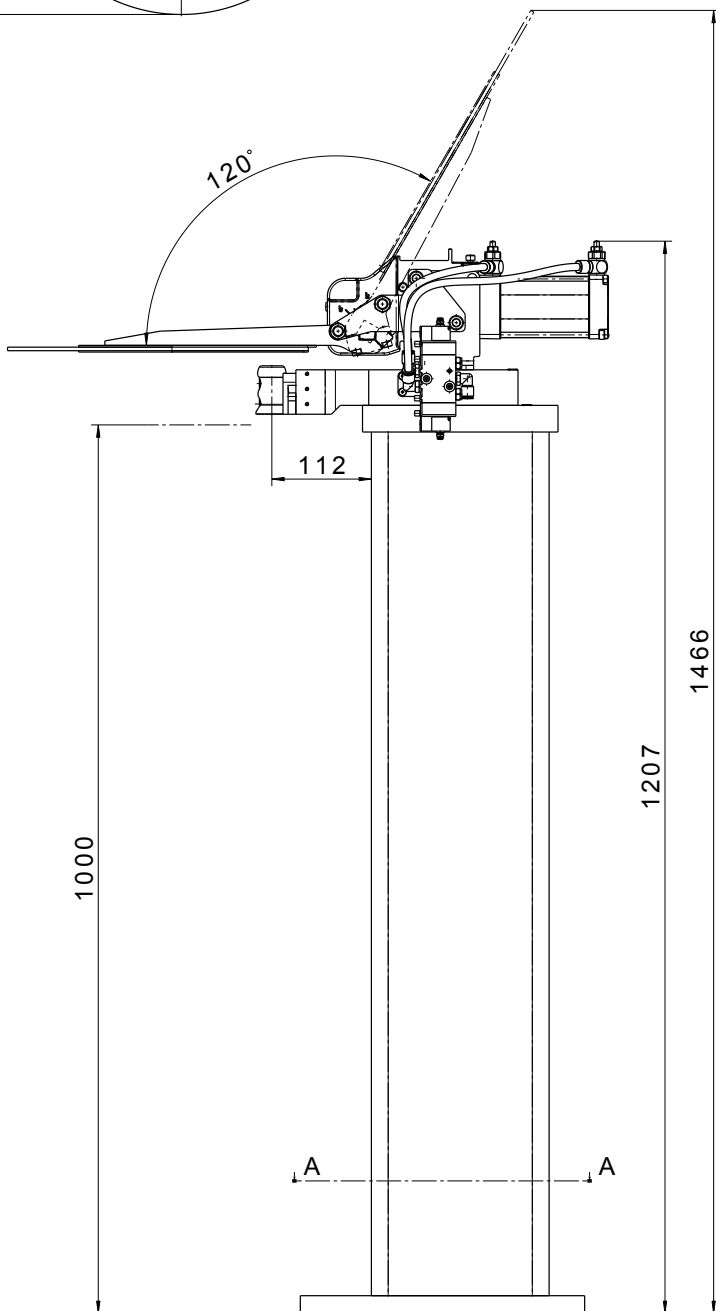

view A-A

Tool stand base

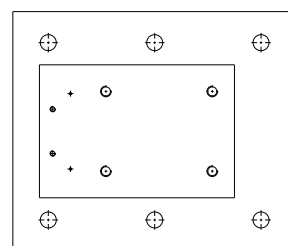
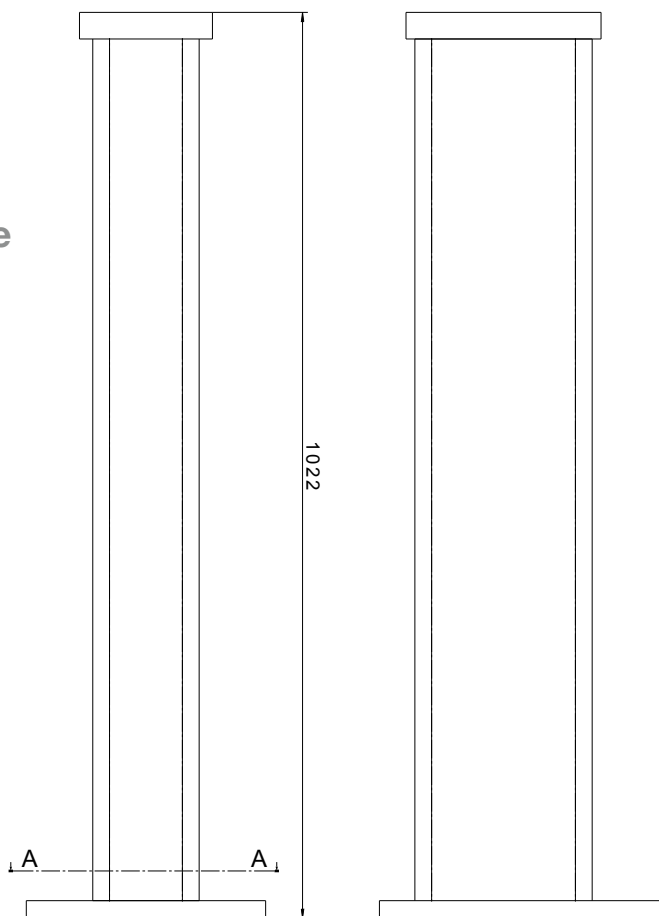

view A-A

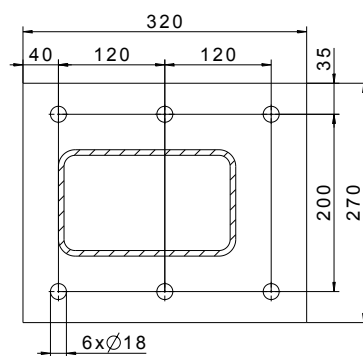

Order no	Description
K81904350	Tool stand base H = 1000 mm, RAL 9003

Positioning plate

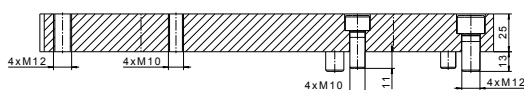

view A-A

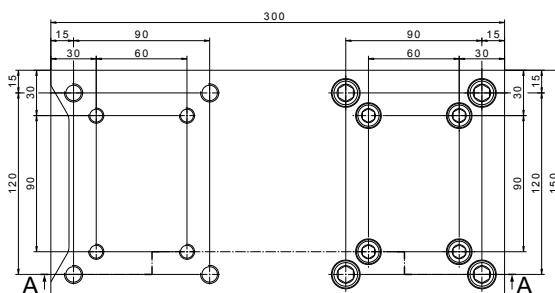

Order no	Description
K81565881	Positioning plate for expanding the storage options, includes mounting materials

MPS 260 TOOL STAND

Tool stand upper part

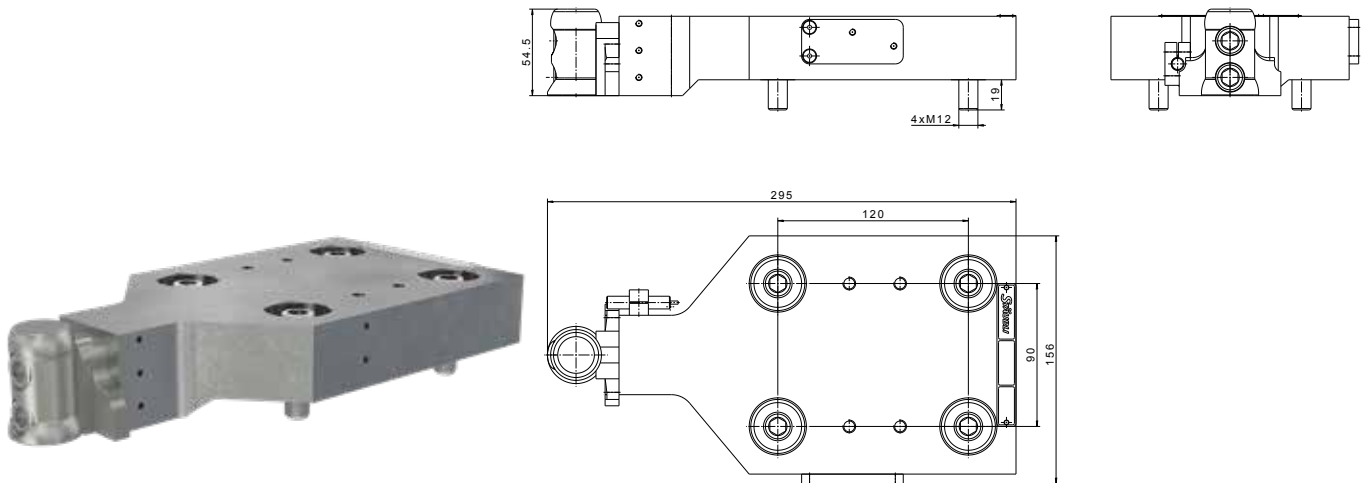

Order no.	Description	Sensors/ connection
K86500908	Tool stand upper part, includes mounting materials	1x PNP/ 1x M12
K86500914		1x NPN/ 1x M12

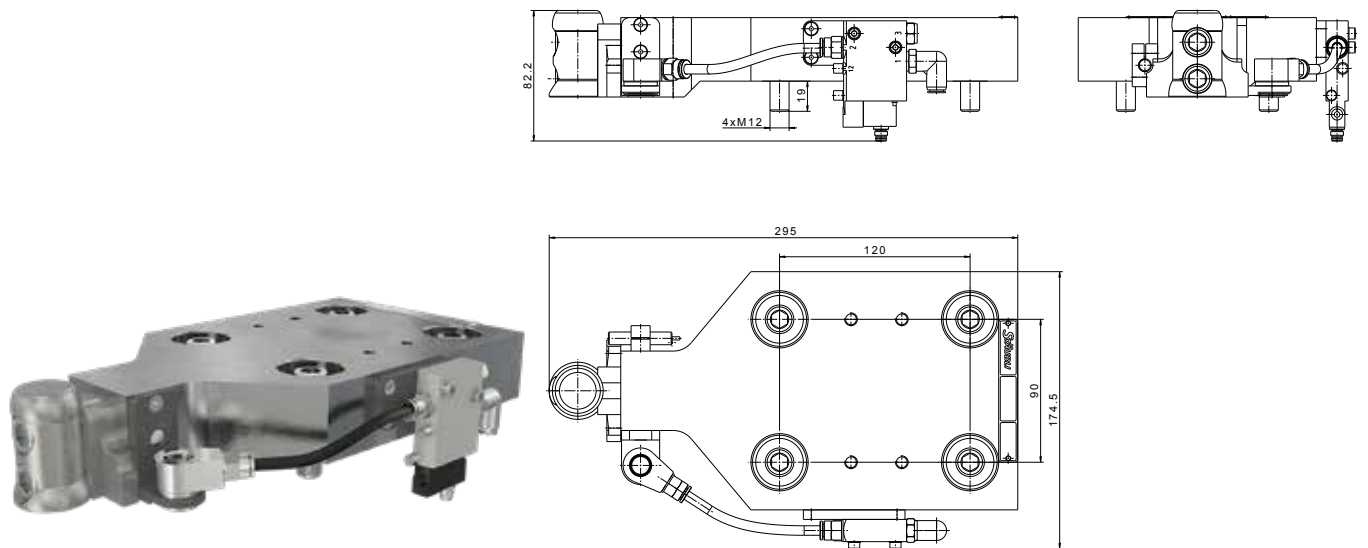

Order no.	Description	Compressed air connection	Sensors/ connection	Valve/ connection
K86500903	Tool stand upper part with Active Docking, includes mounting materials	1x Push-lock hose-Ø 6 mm	1x PNP/ 1x M12	1x M8 4-pole
K86500915			1x NPN/ 1x M12	1x M8 4-pole

Protective cover

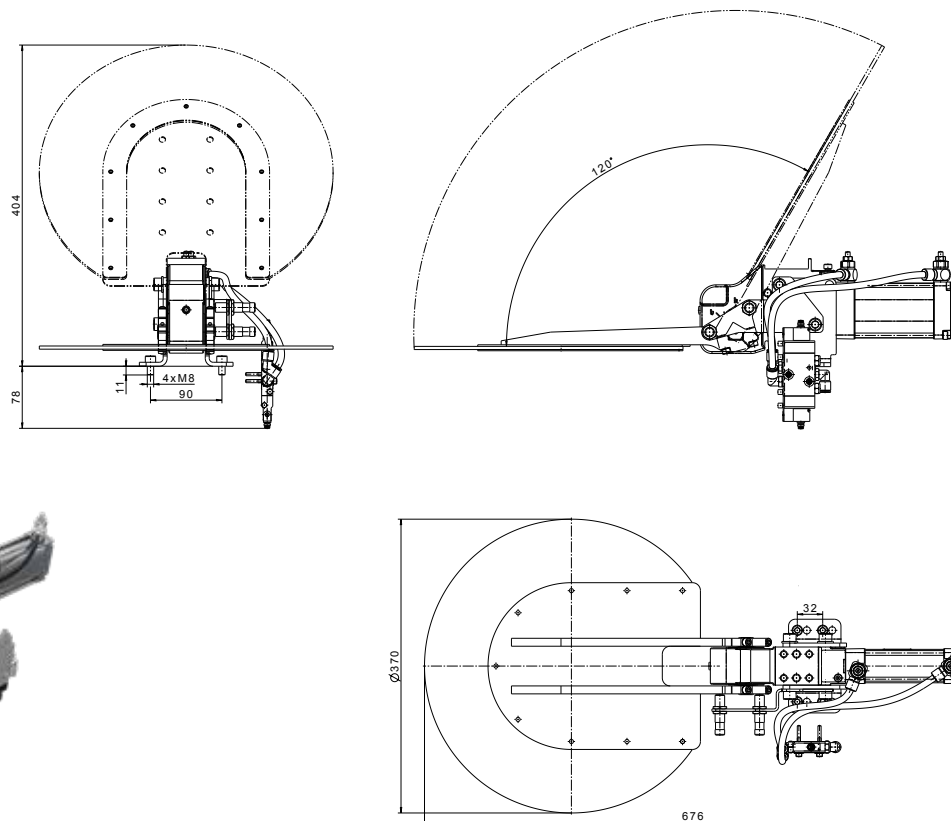

Order no.	Description	Compressed air connection	Sensors/ connection	Valve/ connection
K81562434	Protective cover for harsh working environments; RAL 1004, includes mounting materials	1x Push-lock hose-Ø 6 mm	PNP/ M12	2x M8 4-pole
K81562436			NPN/ M12	2x M8 4-pole

Accessories

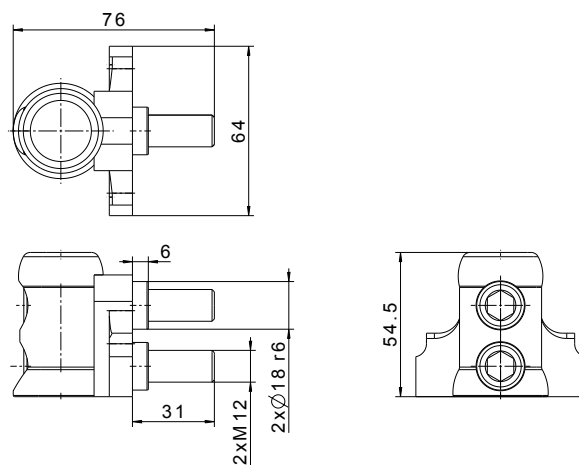

Order no.	Description
K81560450	Docking pin for self-assembly, includes mounting materials

Transfer modules for your production technology

Transfer modules for fluid, pneumatic and vacuum connectors



from page 86 onwards

Ground pin modules for shielding and earth connection



from page 91 onwards

Primary circuit modules for welding power transmission



from page 92 onwards

Transfer modules for tool coding



from page 90 onwards

Integrated IDA bus module for condition monitoring



from page 94 onwards

MultiDNet electrical modules for signal and servo power transmission



from page 98 onwards

Active Docking safety modules Performance Level d, Category 3



from page 106 onwards

SPM 08 transfer modules for fluids and pneumatics

Technical description

- clean-break technology for safe, leak-free media transfer
- no contamination of the workplace, no ingress of air into the media circuits
- cartridge system (Quick Change Inserts) for fast and easy maintenance
- large volume flows, low flow resistance

R

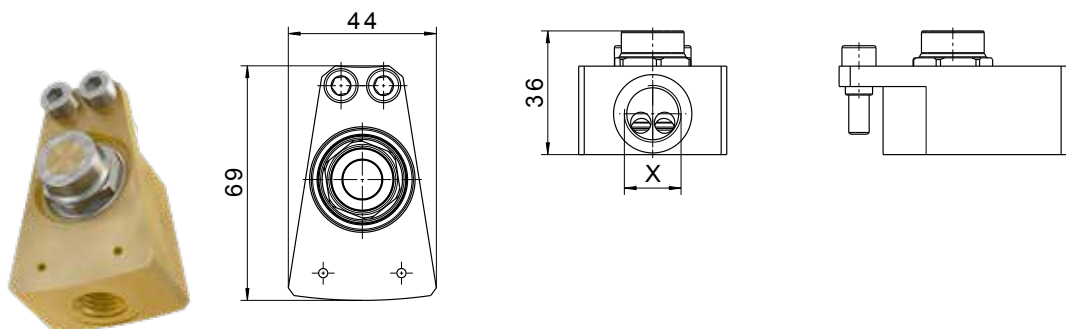

T

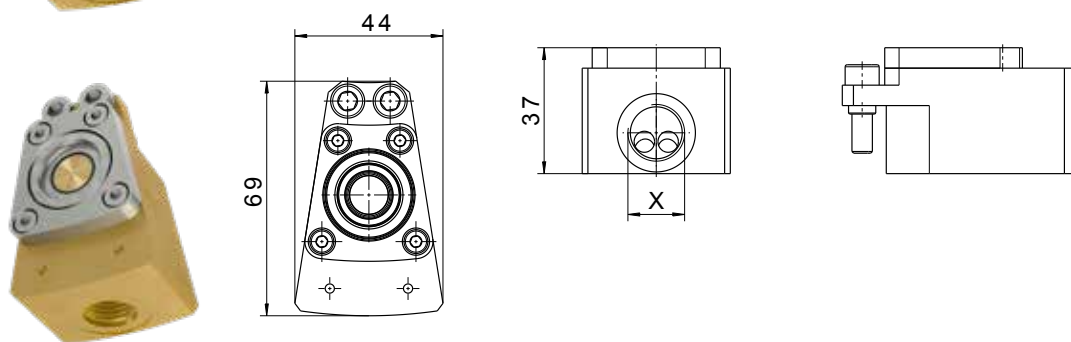

	Order no.	Nominal width	Circuits	Valve	Pressure (max.)	Flow rate (max.)	Connection (X)	Module order code
R	K81565679	8 mm	1	Both sides clean-break	1.6 MPa	15 l/min* 131 Nm ³ /h**	G 3/8 Inner thread	WA
T	K81565680							
R	K81560810	8 mm	1	Both sides clean-break	1.6 MPa	15 l/min* 131 Nm ³ /h**	NPT 3/8 Inner thread	WF
T	K81560811							
R	K81560808	8 mm	1	Both sides clean-break	1.6 MPa	15 l/min* 131 Nm ³ /h**	Rc 3/8 Inner thread	WK
T	K81560809							

* for liquids at 5 m/s, ** for gases.

RMK 06 transfer modules for pneumatics

Technical description

- quick and easy replacement of the couplings
- large volume flows, low flow resistance
- extremely robust design guaranteeing a high number of mating cycles

R

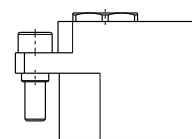
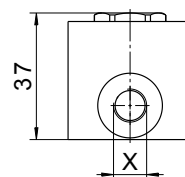
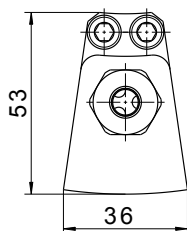

T

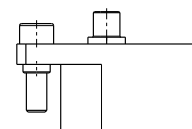
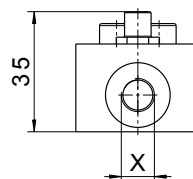
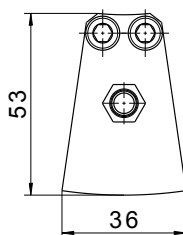

	Order no.	Nominal width	Circuits	Valve	Pressure (max.)	Flow rate (max.)	Connection (X)	Module order code
R	K81560467	6 mm	1	One-sided	1.0 MPa	67 Nm ³ /h	G 1/8 Inner thread	WB
T	K81560468			Free passage				
R	K81560814	6 mm	1	One-sided	1.0 MPa	67 Nm ³ /h	NPT 1/8 Inner thread	WG
T	K81560815			Free passage				
R	K81560812	6 mm	1	One-sided	1.0 MPa	67 Nm ³ /h	Rc 1/8 Inner thread	WL
T	K81560813			Free passage				

FTM transfer modules for pneumatics and vacuum

Technical description

- free passage guarantees high volume flows with low flow resistance
- suitable for the transfer of up to 90% vacuum
- extremely robust design guaranteeing a high number of mating cycles

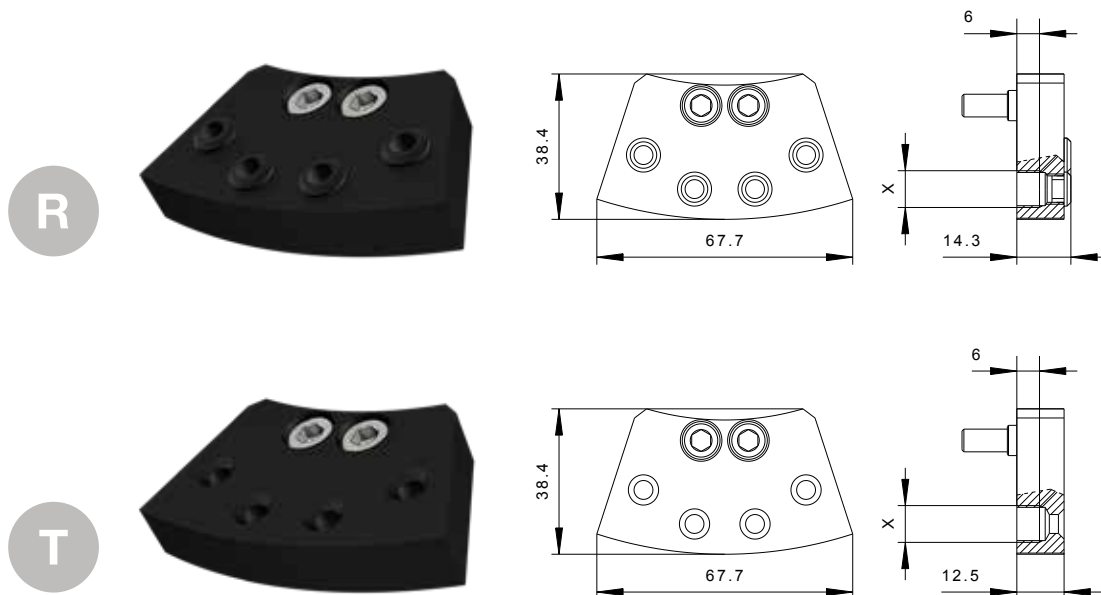

	Order no	Nominal width	Circuits	Valve	Pressure (max.)	Flow rate (max.)	Connection (X)	Module order code
R	K81579479	5 mm	4	Free passage	1.0 MPa	37.32 Nm ³ /h	G 1/8 Inner thread	P4WP
T	K81579480							
R	K81579481	5 mm	4	Free passage	1.0 MPa	37.32 Nm ³ /h	NPT 1/8 Inner thread	P4WQ
T	K81579482							
R	K81579483	5 mm	4	Free passage	1.0 MPa	37.32 Nm ³ /h	Rc 1/8 Inner thread	P4WR
T	K81579484							

When mounting the module on the MPS 260 at module space 1-4, only 3 of the total of 4 connections can be used due to the restricted space.

R

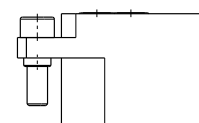
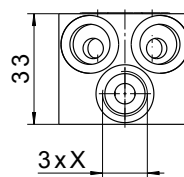
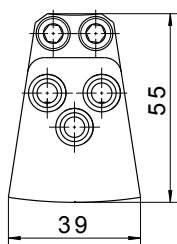

T

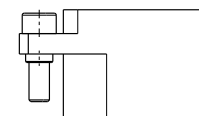
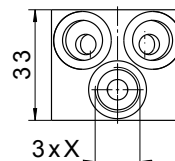
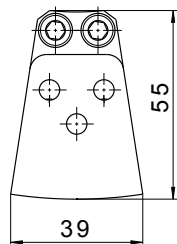

	Order no	Nominal width	Circuits	Valve	Pressure (max.)	Flow rate (max.)	Connection (X)	Module order code
R	K81560806	6 mm	3	Free passage	1.0 MPa	43.97 Nm ³ /h	G 1/4 Inner thread	WD
T	K81560807							
R	K81560822	6 mm	3	Free passage	1.0 MPa	43.97 Nm ³ /h	NPT 1/4 Inner thread	WJ
T	K81560823							
R	K81560820	6 mm	3	Free passage	1.0 MPa	43.97 Nm ³ /h	Rc 1/4 Inner thread	WO
T	K81560821							

R

T

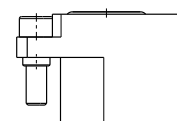
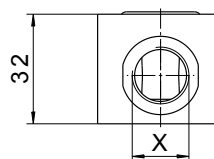
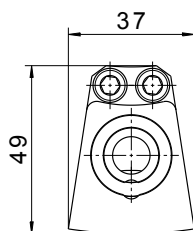

	Order no	Nominal width	Circuits	Valve	Pressure (max.)	Flow rate (max.)	Connection (X)	Module order code
R	K81565682	11 mm	1	Free passage	1.0 MPa	215.02 Nm ³ /h	G 3/8 Inner thread	WE
T								
R	K81560825	11 mm	1	Free passage	1.0 MPa	215.02 Nm ³ /h	NPT 3/8 Inner thread	WI
T								
R	K81560824	11 mm	1	Free passage	1.0 MPa	215.02 Nm ³ /h	Rc 3/8 Inner thread	WN
T								

Transfer modules for tool coding

Technical description

- individual coding of tool sides
- four inductive proximity switches on the robot side
- mechanical adjustment of the coding with an adjusting screw on the tool side

R

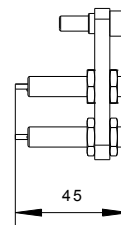
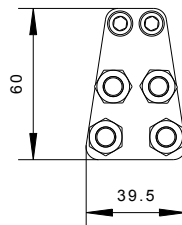

T

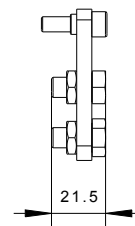
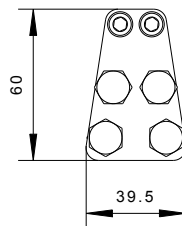

	Order no.	Sensors/ connection	Module order code
R	K81579644	PNP/ 4x M8 3-pin - cable length 0.4 m	MX
T	K81579646	Mechanical opposing side	
R	K81579645	NPN/ 4x M8 3-pin - cable length 0.4 m	MY
T	K81579646	Mechanical opposing side	

Ground pin modules for shielding and earth connection

Technical description

- excellent power transmission with patented Stäubli MULTILAM technology
- Stäubli “Floating Contact Technology” guarantees wear-free connections
- low weight

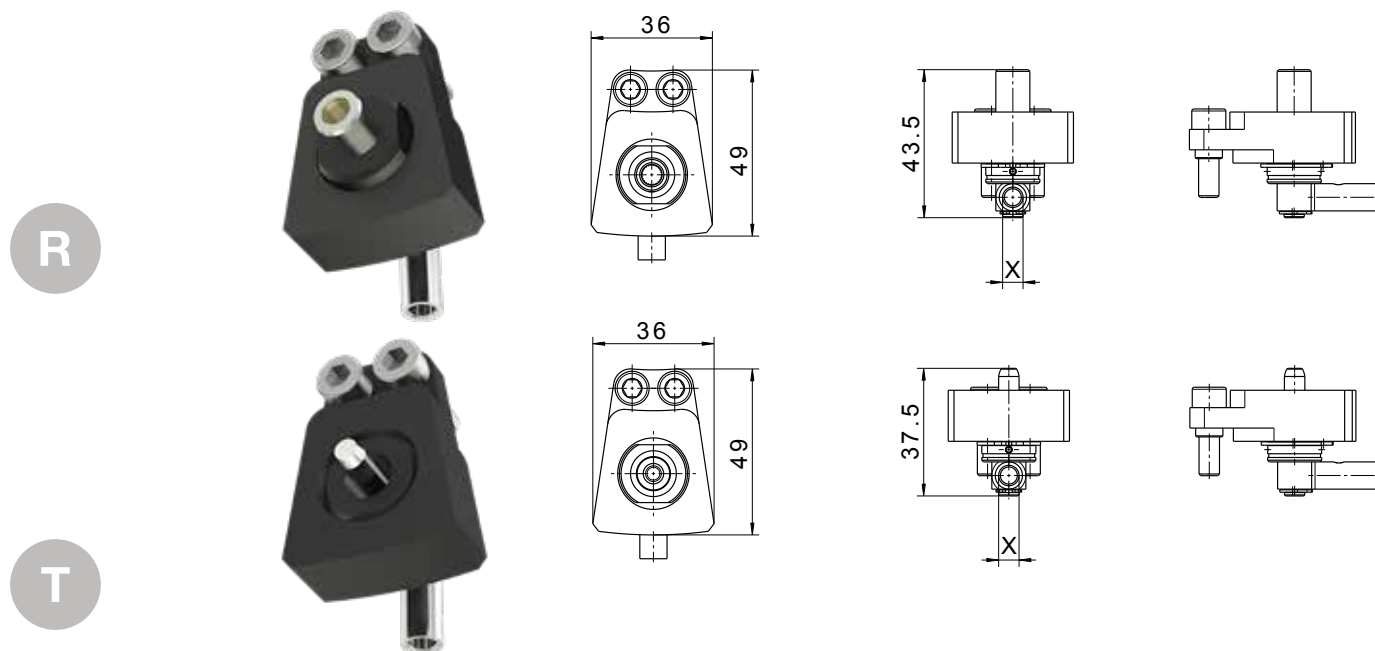

	Order no.	Transmission poles	Voltage/ current	Cable cross-section	Connection (X)	Module order code
R	K81565744	1	55 VAC/ 75 A	10 mm ²	crimp barrel	MQ
T	K81565745					

WPC2 Primary circuit modules for welding power transmission

Technical description

- excellent power transmission with patented Stäubli MULTILAM technology
- suitable for high frequency transmission of up to 10 kHz with HF cables
- Stäubli “Floating Contact Technology” guarantees wear-free connections
- protection class: IP 65 (in a coupled state)

R

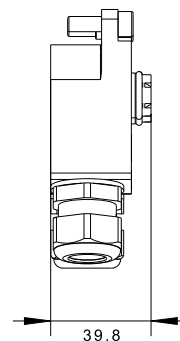
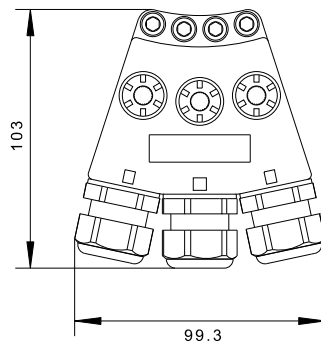

T

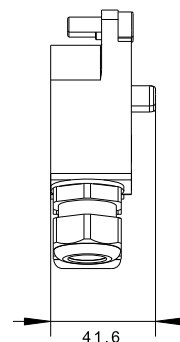
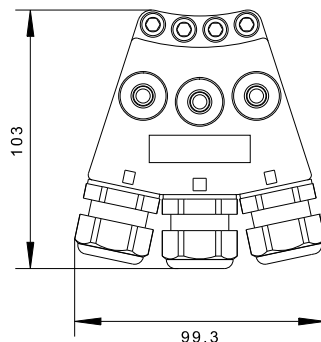

	Order no.	Transmission poles	Voltage/ current	Cable cross-section	Screw	Clamping range	Module order code
R	K81579712	2+PE	1000 VAC/ 175 A	16 mm ² / 22 mm ² (4AWG)/ 25 mm ² / 35 mm ²	3x M25	8-15 mm	WPAB
T	K81579713						

Integrated bus module IDA for condition monitoring

The integrated IDA bus module is a freely programmable I/O module for network transmission housed in the MultiDNet-R electrical module. The IDA enables the space-saving and functional connection of the condition monitoring unit to the robotic tool changing system and to the next-higher control level.

Easy-to-read LED status displays and convenient web server configuration make the IDA even easier to use. An integrated current cut-off module for the 24V power supply prevents contact wear without any programming effort.

Technical description

- compact design
- compatible with Modbus TCP, Ethernet/ IP and ProfiNet
- LEDs for operating states
- configuration with a web server
- freely programmable I/O module
- integrated 6 bit tool coding

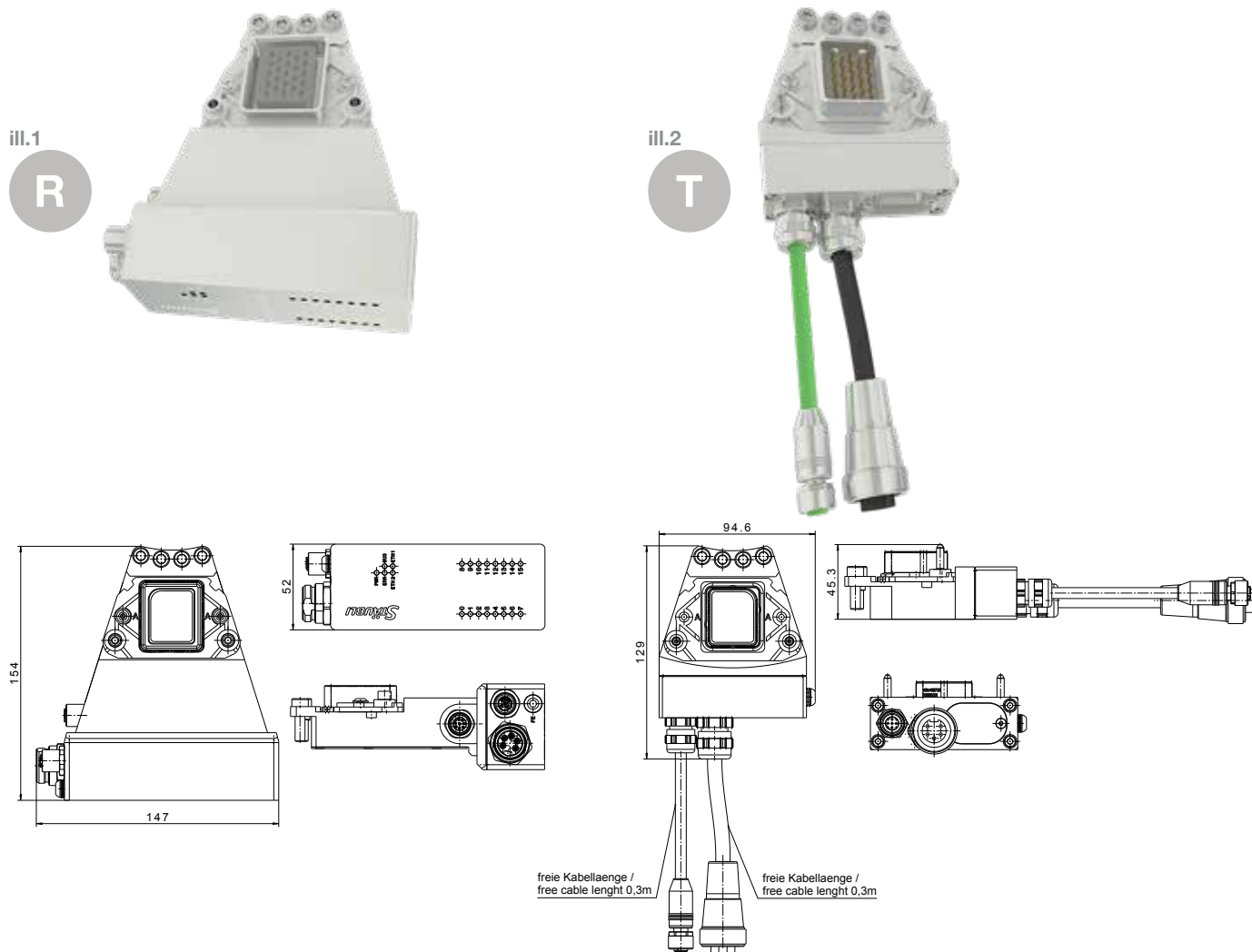

	Order no.	Description	Connection	Module order code	ill.
R	K81451508	Integrated IDA bus module for condition monitoring	7/8 5-pole M12-D coded	IDAB	1
T	K81451509				2

The wiring diagram can be found on page 110.

The IDAB module can only be used in conjunction with the basic units of the robot side MPS080RC, MPS080RD, MPS130RC, MPS130RD, MPS260RC and MPS260RD.

Accessories for connectors

	Order no.	Mating connector	Connection	Connection type	Suitable for
R	B27595985	straight cable output	M12-D coded	Screw terminal	IDAB
R	B27595660	straight cable output	7/8 5-pole		
T	B27595985	straight cable output	M12-D coded		
T	B27595653	straight cable output	7/8 5-pole		

Integrated bus module IDA for condition monitoring

Electrical and mechanical data

Supply	
Supply voltage	24 V DC
Permissible range	18 to 30 V DC
Power supply connection technology	Power supply connection 7/8 5-pole
Potential separation	Galvanic separation of the voltage groups V1- and AUX2, Dielectric strength up to 500 V DC

System data	
Fieldbus transfer rate	10 Mbps/ 100 Mbps
Fieldbus connection technology	Connection data M12-D coded
Automatic protocol recognition	Web server standard: 192.168.1.254
Service interface	ident. connection data M12-D coded

Modbus TCP	
Addressing	Static IP, BOOTP, DHCP
Function codes supported	FC1, FC2, FC3, FC4, FC5, FC6, FC15, FC16, FC23
Number of TCP connections	8
Input register start address	0 (0x0000 hex)
Output register start address	2048 (0x0800 hex)

Ethernet/ IP	
Addressing	in accordance with Ethernet/ IP™ specification
Quick Connect (QC)	< 500 ms
Device Level Ring (DLR)	supported
Number of TCP connections	3
Number of CIP connections	10
Input Assembly Instance	103
Output Assembly Instance	104
Configuration Assembly Instance	106

PROFINET	
Addressing	DCP
Conformance class	B (RT)
MiniCycleTime	1 ms
Fast Start-Up (FSU)	< 250 ms
Diagnostics	in accordance with PROFINET alarm handling
Topology recognition	supported
Automatic addressing	supported
Media Redundancy Protocol (MRP)	supported

General data

Standard/ directive conformity	
Electromagnetic compatibility	per EN 61131-2
General information	
Dimensions (W x L)	46 x 115 mm
Operating temperature	-40 to +45 °C
Storage temperature	-40 to +85 °C
Halogen-free	Yes

MultiDNet electrical module for signal and servo power transmission

Technical description

- excellent power transmission with patented Stäubli MULTILAM technology
- robust contact technology
- protection class: IP 65 (in a coupled state)
- excellent shielding technology for secure data and power transmission

Signal transmission ProfiNet

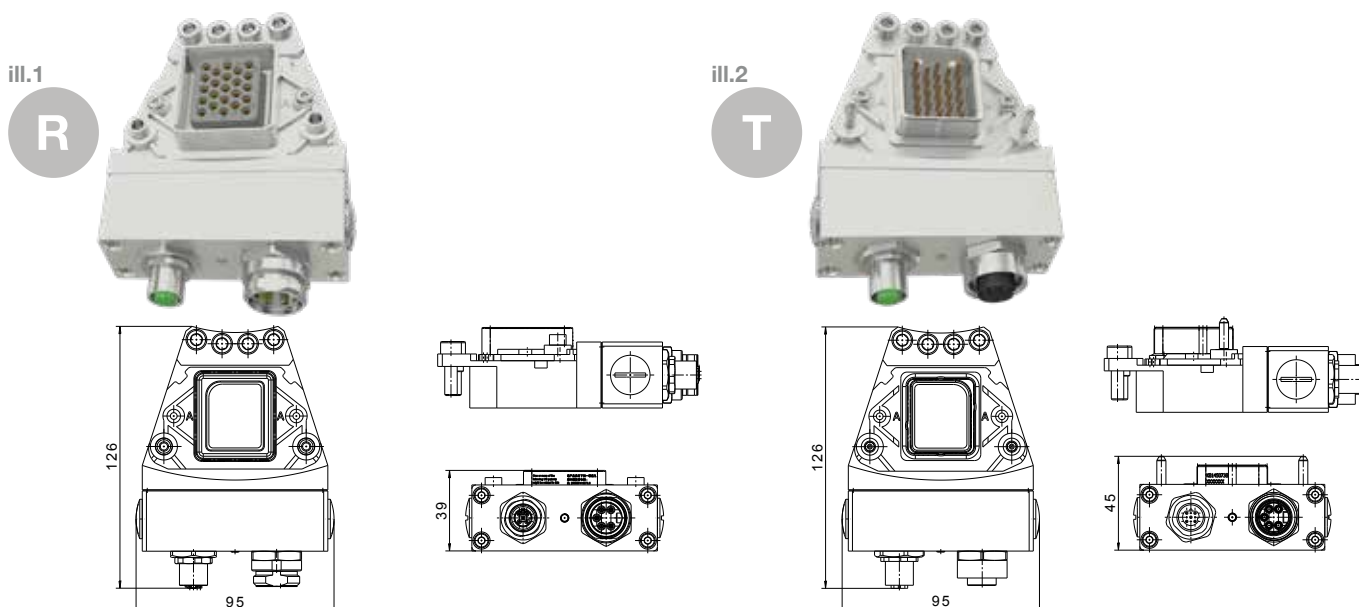

	Order no.	Transmission poles	Voltage/ current (max.)	Connection	Module order code	ill.
R	K81451461	4+SH and 4+PE	250 VAC/ 4 A - 250 VAC/ 6 A	7/8" 5-pole M12-D coded	ECAK	1
T	K81451462	4+SH and 4+PE	250 VAC/ 4 A - 250 VAC/ 6 A	7/8" 5-pole M12-D coded	ECAK	2

The wiring diagram can be found on page 111.

Accessories for connectors

	Order no.	Mating connector	Connection	Connection type	Suitable for
R	B27595985	straight cable output	M12-D coded	screw terminal	ECAK
R	B27595660	straight cable output	7/8" 5-pole		
T	B27595985	straight cable output	M12-D coded		
T	B27595653	straight cable output	7/8" 5-pole		

Signal transmission GigaDock

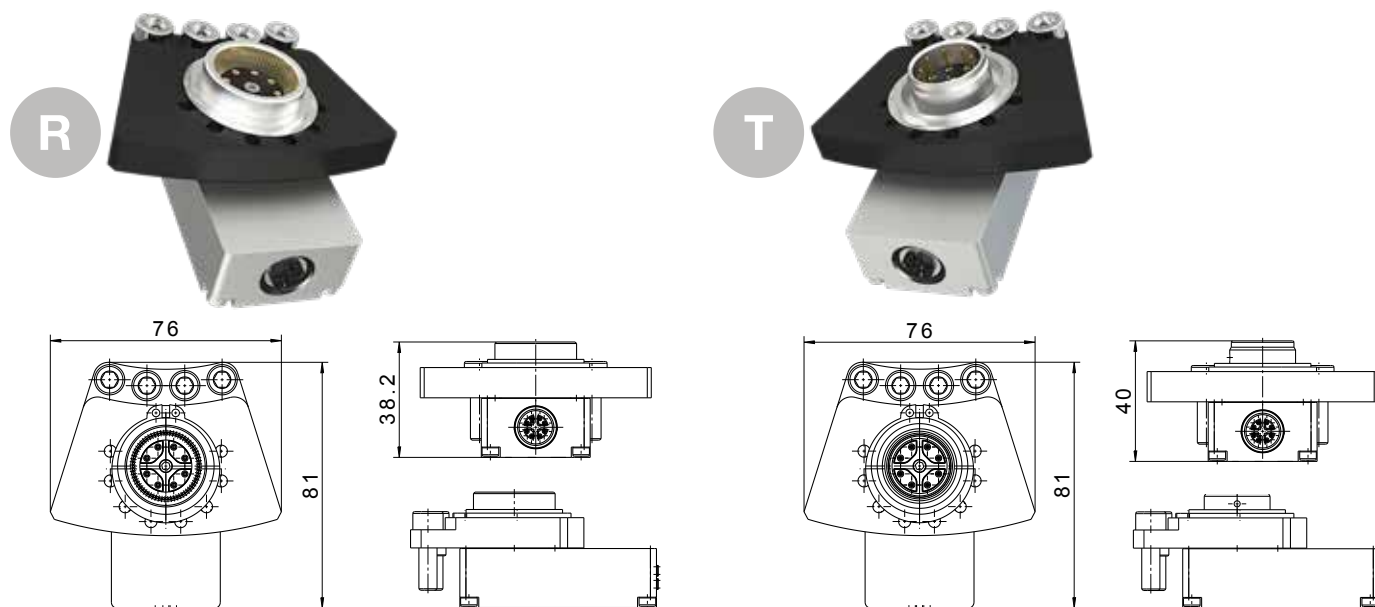

	Order no.	Type	Plug connection	Suitable for	Degree of protection	Description	Module order code
R	K81579316	GigaDock10 S90-RS-M12X	M12 socket x-coded	Network cable, Ethernet, CAT6A, 8 pin (10 GBit/s)	IP65	Pre-assembled and tested connector	ECAG
T	K81579317	GigaDock10 S90-TS-M12X					



According to the ProfiNet guidelines, the GigaDock electric module is equipped with a X-coded socket. Suitable for use in applications with Gigabit Ethernet and docked camera systems.

MPS 080/130/260 TRANSFER MODULES

Signal transmission and docking signals

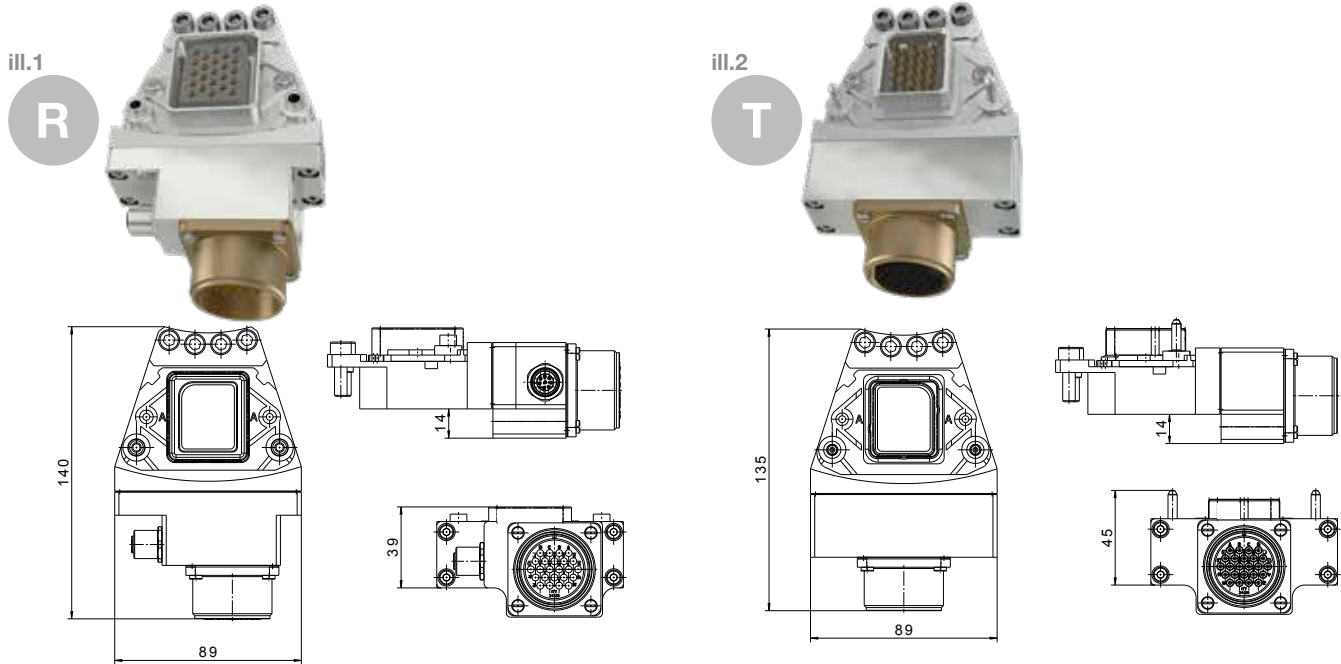

	Order no.	Transmission poles	Voltage/ current (max.)	Connection*	Module order code	ill.
R	K81451266	18 + dock signal	60 VDC/ 30 VAC - 7.5 A	CA3102E-24-28P	ECAI	1
T	K81451267	18	60 VDC/ 30 VAC - 7.5 A	CA3102E-24-28S		2

* ITT Cannon, Amphenol and DDK are standardised connectors and plug-compatible.
The wiring diagram can be found on page 112.

Accessories for connectors

	Order no.	Mating connector	Connection**	Connection type	Suitable for
R	B27597976	straight cable output	CA3106E-24-28S	crimp barrel	ECAI
R	B27597978	90° cable output	CA3108E-24-28S		
T	B27597977	straight cable output	CA3106E-24-28P		
T	B27597979	90° cable output	CA3108E-24-28P		

** Depending on the connection cable used, the maximum number of poles that can be assigned may be reduced when assembling the connection plug.
The connection cables are not included in the scope of delivery.

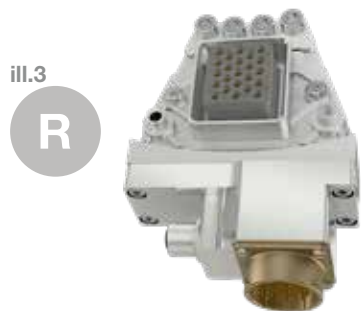

R

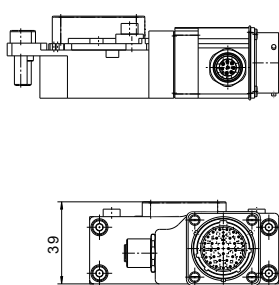
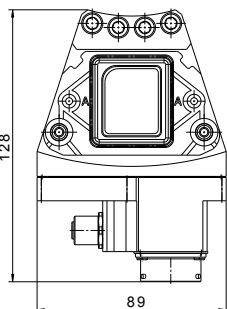

T

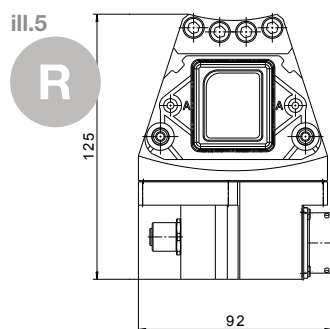
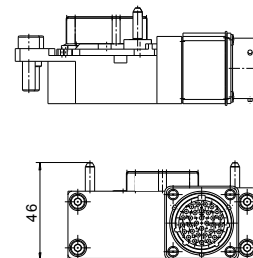
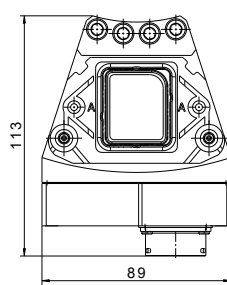

R

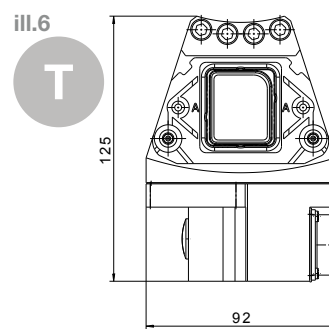
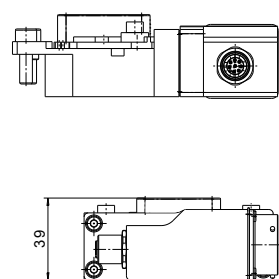
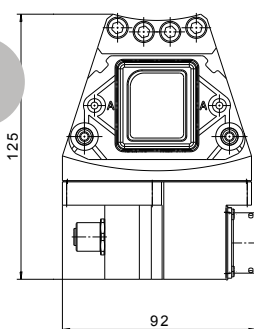

T

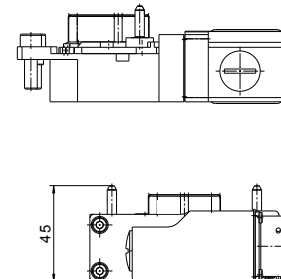
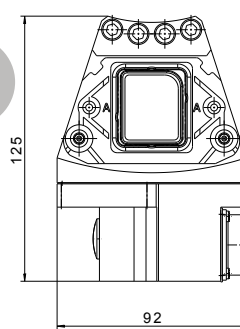

	Order no.	Transmission poles	Voltage/ current (max.)	Connection*	Module order code	ill.
R	K81451174	23 + dock signal	60 VDC/ 30 VAC - 7.5 A	KPT2E18-32P	ECAB	3
T	K81451010	23	60 VDC/ 30 VAC - 7.5 A	KPT2E18-32S		4
R	K81451231	23 + dock signal	60 VDC/ 30 VAC - 7.5 A	KPT2E18-32P	ECAE	5
T	K81451232	23	60 VDC/ 30 VAC - 7.5 A	KPT2E18-32S		6

* ITT Cannon, Amphenol and DDK are standardised connectors and plug-compatible.
The wiring diagram can be found on page 115.

Accessories for connectors

	Order no.	Mating connector	Connection	Connection type	Suitable for
R	B27597734	straight cable output	KPTC6F18-32S	crimp barrel	ECAB and ECAE
R	B27597735	90° cable output	KPTC8F18-32S		
T	B27597737	straight cable output	KPTC6F18-32P		
T	B27597738	90° cable output	KPTC8F18-32P		

MPS 080/130/260 TRANSFER MODULES



R

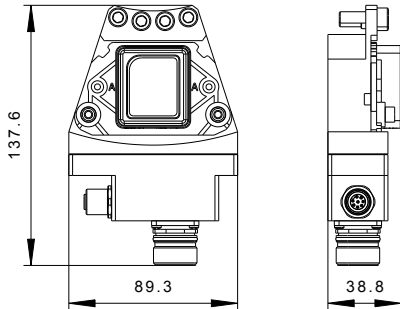

T

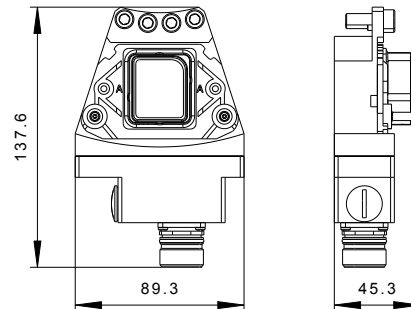

	Order no.	Transmission poles	Voltage/ current (max.)	Connection	Module order code	ill.
R	K81452500	13 + dock signal	63 VDC/ 63 VAC - 7 A	A EG A 560 MR 93 00 0201 400	ECAL	7
T	K81452502	13	63 VDC/ 63 VAC - 7 A	A EG A 561 FR 91 00 0201 400		8

The wiring diagram can be found on page 113.

Accessories for connectors

	Order no.	Mating connector	Connection**	Connection type	Suitable for
R	B27597873	straight cable output	A ST A 558 FR 92 73 0100 000	crimp barrel	ECAL
R	B27598497	90° cable output	A SD A 558 FR 91 58 0100 400		
T	B27598481	straight cable output	A ST A 559 MR 93 73 0100 400		
T	B27598589	90° cable output	A SD A 559 MR 93 42 0100 000		

** Depending on the connection cable used, the maximum number of poles that can be assigned may be reduced when assembling the connection plug. The connection cables are not included in the scope of delivery.

Signal transmission

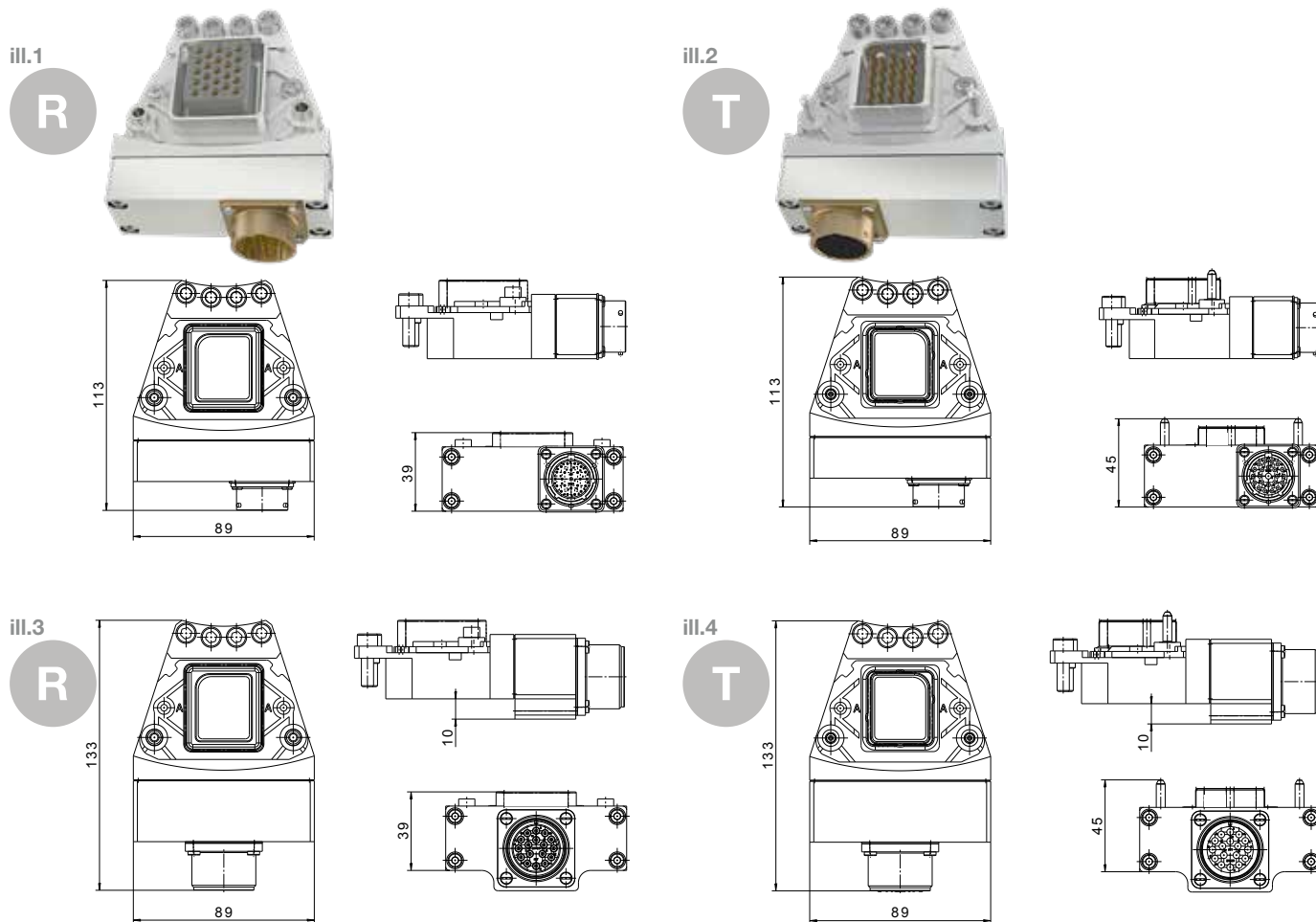

	Order no.	Transmission poles	Voltage/ current (max.)	Connection*	Module order code	ill.
R	K81451007	23	60 VDC/ 30 VAC - 7.5 A	KPT2E16-23P	ECAA	1
T	K81451008			KPT2E16-23S		2
R	K81451264	17	60 VDC/ 30 VAC - 7.5 A	CA3102E-20-29P	ECAD	3
T	K81451265			CA3102E-20-29S		4

* ITT Cannon, Amphenol and DDK are standardised connectors and plug-compatible.
The wiring diagram can be found on page 116.

Accessories for connectors

	Order no.	Mating connector	Connection	Connection type	Suitable for
R	B27597727	straight cable output	KPTC6F16-23S	crimp barrel	ECAA
R	B27597728	90° cable output	KPTC8F16-23S		
T	B27597731	straight cable output	KPTC6F16-23P		
T	B27597732	90° cable output	KPTC8F16-23P		
R	B27597972	straight cable output	CA3106E-20-29S	crimp barrel	ECAD
R	B27597974	90° cable output	CA3108E-20-29S		
T	B27597973	straight cable output	CA3106E-20-29P		
T	B27597975	90° cable output	CA3108E-20-29P		

MPS 080/130/260 TRANSFER MODULES

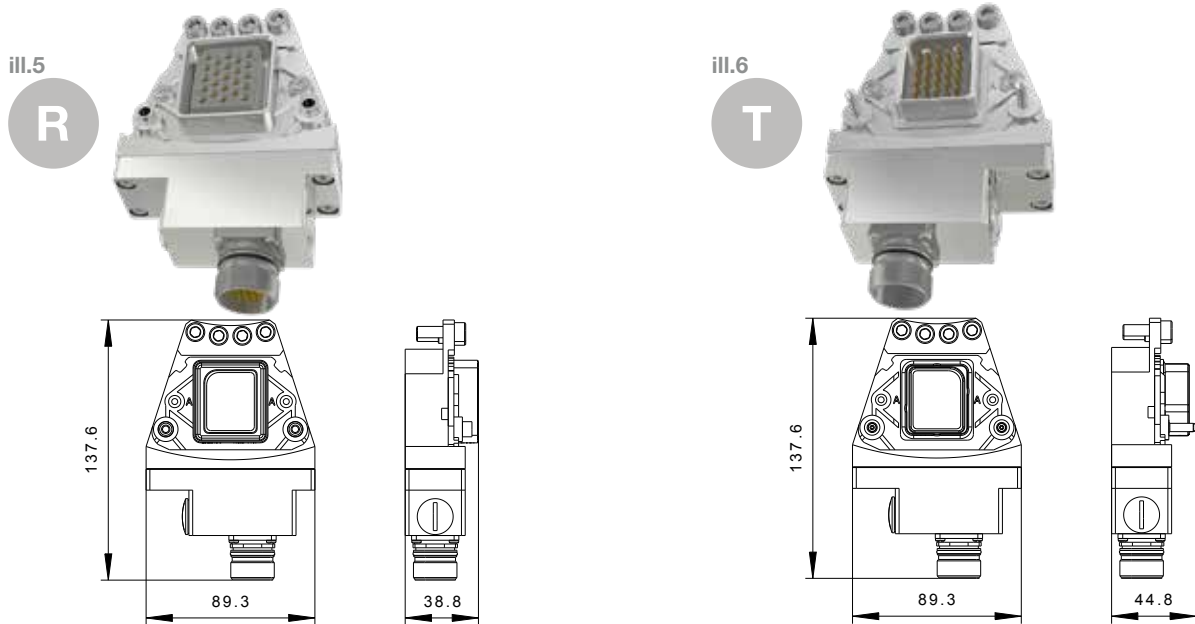

	Order no.	Transmission poles	Voltage/ current (max.)	Connection	Module order code	ill.
R	K81452501	19	63 VDC/ 63 VAC - 7 A	A EG A 560 MR 93 00 0201 400	ECAM	5
T	K81452502	19	63 VDC/ 63 VAC - 7 A	A EG A 561 FR 91 00 0201 400		6

The wiring diagram can be found on page 114.

Accessories for connectors

	Order no.	Mating connector	Connection	Connection type	Suitable for
R	B27597873	straight cable output	A ST A 558 FR 92 73 0100 000	crimp barrel	ECAM
R	B27598497	90° cable output	A SD A 558 FR 91 58 0100 400		
T	B27598481	straight cable output	A ST A 559 MR 93 73 0100 400		
T	B27598589	90° cable output	A SD A 559 MR 93 42 0100 000		

Servo power transmission

ill.1

R

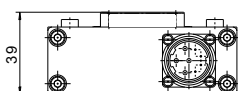
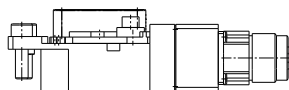
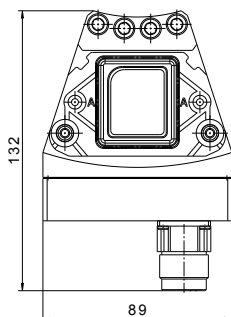

ill.2

T

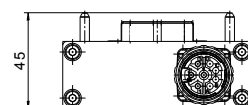
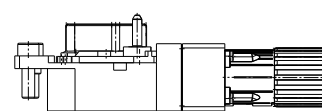
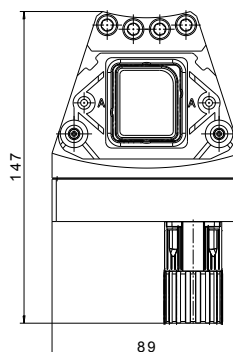

ill.3

R

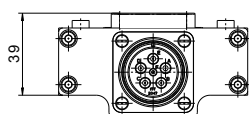
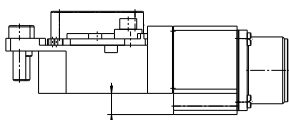
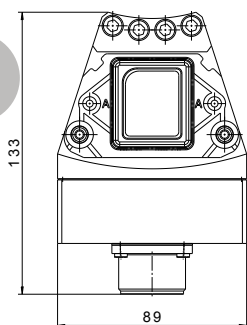

ill.4

T

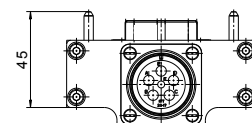
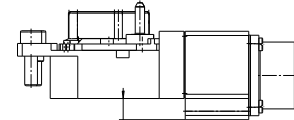
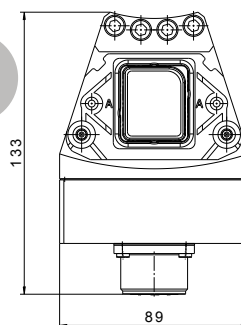

	Order no.	Transmission poles	Voltage/ current (max.)	Connection*	Module order code	ill.
R	K81451011	3+PE+4	630 VDC/ 30 A - 250 VAC/ 7 A	B EG A 120 MR 11 00 0200 400	ECAC	1
T	K81451012			B DF A 108 FR 05 00 0150 000		2
R	K81451268	3+PE+2	400 VAC/ 22 A - 250 VAC/ 7 A	CA3102E-20-17P	ECAF	3
T	K81451269			CA3102E-20-17S		4

* ITT Cannon, Amphenol and DDK are standardised connectors and plug-compatible.
The wiring diagram can be found on page 117.

Accessories for connectors

	Order no.	Mating connector	Connection	Connection type	Suitable for
R	B27597360	straight cable output	B ST A 078 FR 05 42 0235 400	crimp barrel	ECAC
T	B27597414	straight cable output	B KU A 199 MR 38 42 0200 000		
R	B27597980	straight cable output	CA3106E-20-17S	crimp barrel	ECAF
R	B27597982	90° cable output	CA3108E-20-17S		
T	B27597981	straight cable output	CA3106E-20-17P		
T	B27597983	90° cable output	CA3108E-20-17P		

MPS 080/130/260 TRANSFER MODULES

Active Docking safety modules

Performance Level d, Category 3

Technical description

- stand-alone system, independent of the bus system
- easy integration, lower system costs
- integrated pressure switch for locking pressure monitoring
- meets the safety requirements of Performance Level d, Category 3

R

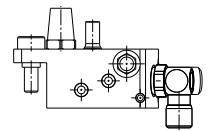
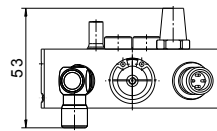
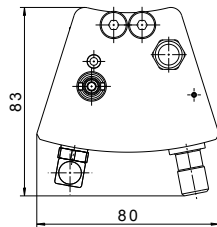

T

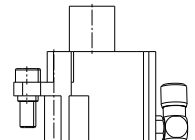
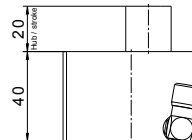
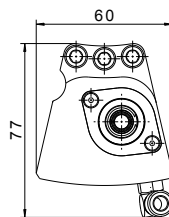

	Order no.	Sensors/ connection	Compressed air connection
R	K81560446	Pressure switch 4.5 bar/ NO	Push-lock hose outer-Ø 6 mm
R	K81565847		
T	K81560447	none	

Transfer coupling MPS 080/130 tool stand

ill.1

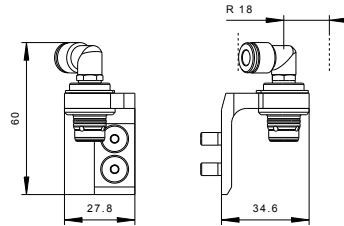

ill.2

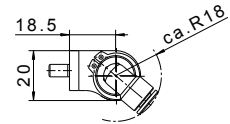

ill.3

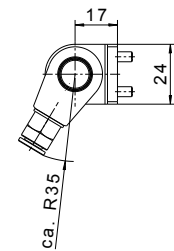
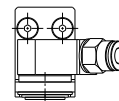
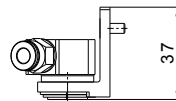

Transfer coupling MPS 260 tool stand

ill.4

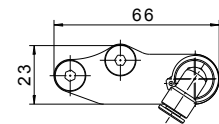
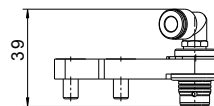

ill.5

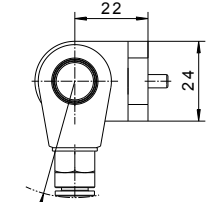
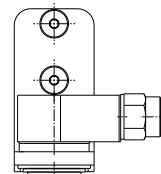
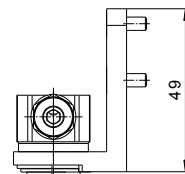

Transfer coupling external tool stand

ill.6

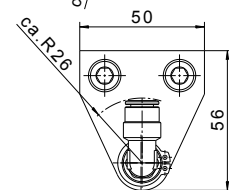
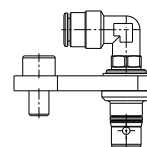
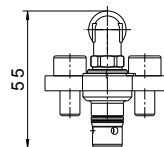

ill.7

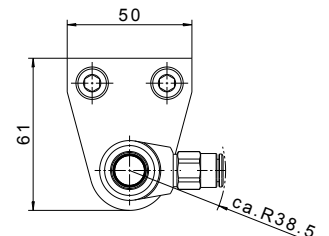
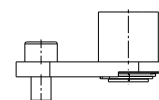
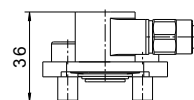

	Order no.	Accessories	Compressed air connection	ill.
T	K81560451	Transfer coupling for MPS 080	Push-lock hose outer-Ø 6 mm	1
T	K81560451	Transfer coupling for MPS 130		2
	K81560452	Transfer coupling tool stand for MPS 080 und MPS 130		3
T	K81560449	Transfer coupling for MPS 260	Push-lock hose outer-Ø 8 mm	4
	K81560448	Transfer coupling tool stand for MPS 260		5
T	K81564871	Transfer coupling for installation to end user tool	Push-lock hose outer-Ø 8 mm	6
	K81564872	Transfer coupling for installation to external tool stand		7

Customer-specific designs



Specialist know-how
from construction to the finished solution



All components from a single source,
perfectly coordinated



Our 125 year-long commitment to innovation and our extensive expertise in all industrial sectors are reflected in our individual solutions for customers around the world. We liaise closely with our customers to develop custom-made systems that are precisely and flexibly adapted to their requirements.

Over the decades, as a pioneer in the development of robotic tool changing systems, Stäubli has consistently implemented the highest precision and quality standards as well as maximum safety aspects with innovative, sustainable and variable technologies. Reflecting these high standards, the modular tool changers

have an open architecture that makes the customer-specific design of perfectly matched systems possible.

Global cost efficiency and quality standards

Companies and corporations rely on standard global production processes ensuring they maintain their own quality standards. This optimises the costs along the entire production resource supply chain. Stäubli consistently supports this approach by developing its own standards for customers with robotic tool changing systems.

Design expertise from a single source

All components of the robotic tool changer systems are developed and manufactured by Stäubli:

- Only proven and certified technologies are used, based on decades of experience, for the comprehensive portfolio of transfer modules and electrical connectors.
- All design, production and quality inspection activities take place within Stäubli.



Face-to-face or online training, competence and experience available worldwide

Worldwide, individual, on-site advice

- Stäubli personnel are available for individual consultations from all their worldwide locations.
- Our technical consultants analyse the production and operating conditions with you at your site.
- Our project planning and design specialists configure the MPS system to your requirements.

Optimum system customisation for maximum productivity

Stäubli implements specific requirements, such as locking units for special payloads or new, process-dependent transfer modules, in optimally adapted and technologically sophisticated systems.

The individual adaptation of the transfer modules is possible with almost all product parameters:

- faster transfer rates due to larger nominal diameters
- customized additions to the plug & play product range
- special media resistance and robustness is achieved through the use of highly resistant and premium quality materials
- customer-specific wiring of electrical connectors with component testing and logging
- development of new transfer modules for specific production technologies



Comprehensive payload range

Stäubli caters for a broad spectrum of payloads from 10 to 2500 kilogrammes and enabling a wide range of applications. Please contact us if the payloads listed in this brochure do not meet your needs.

WIRING DIAGRAMS

IDAB - integrated IDA 130/260 bus module

iii.2

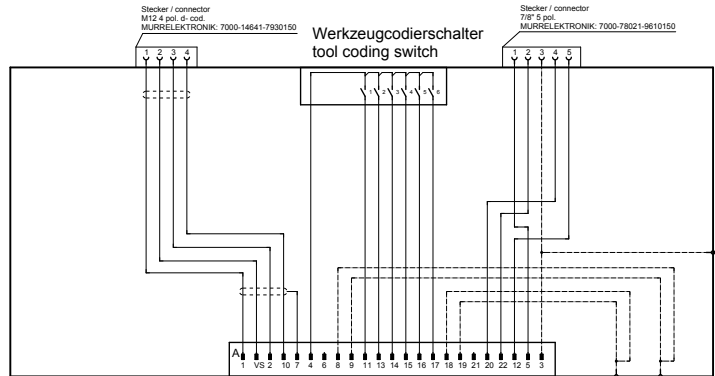

iii.1

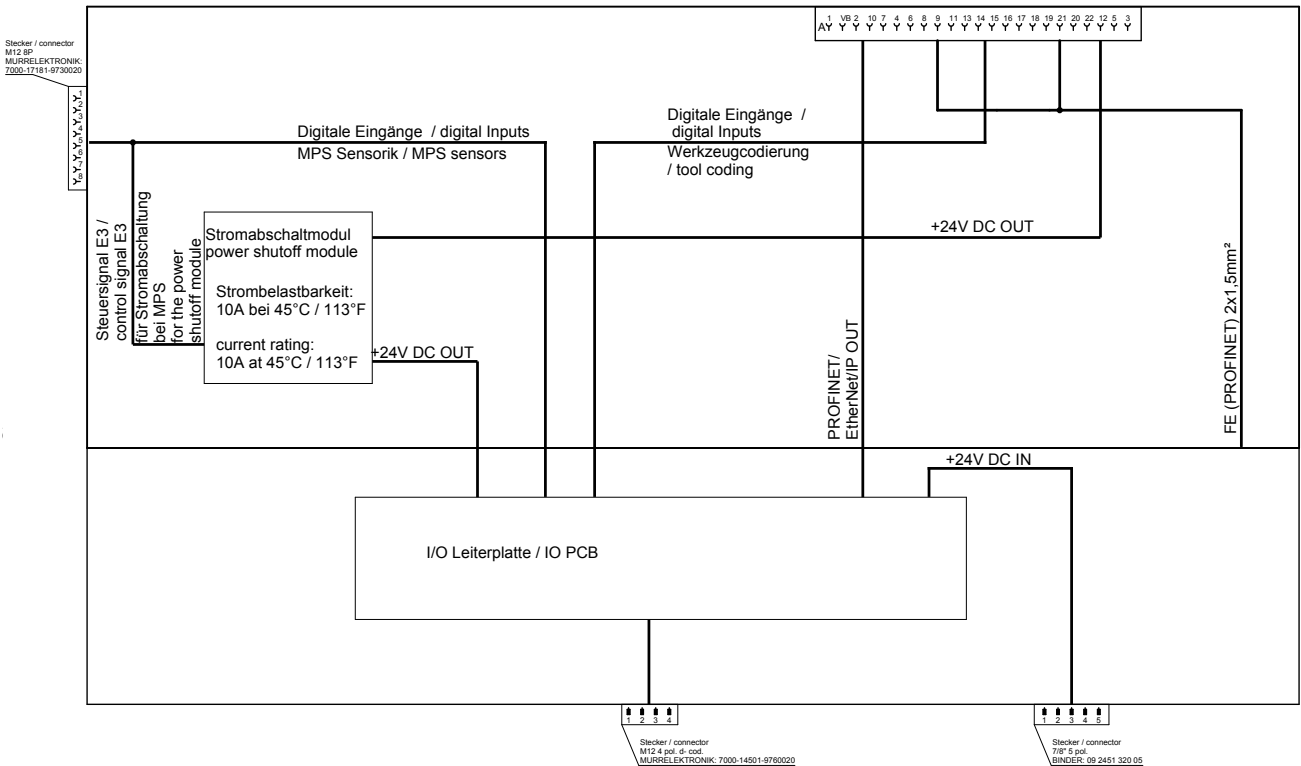

ECAK – Signal transmission ProfiNet

iii.1

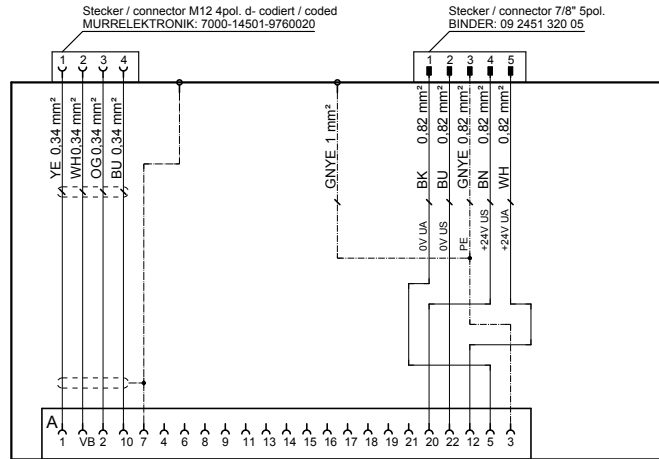

iii.2

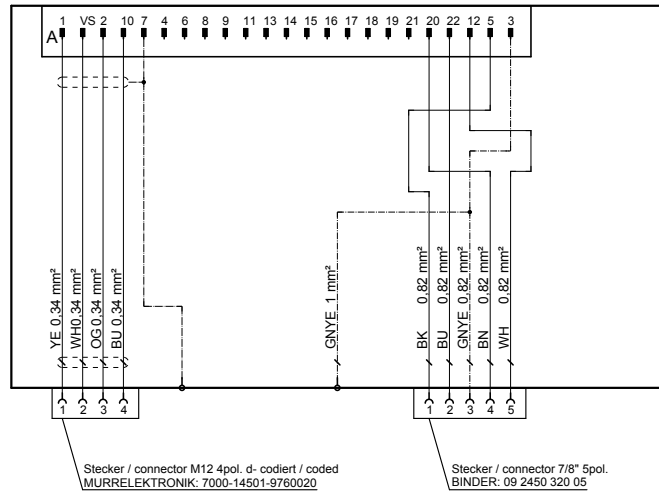

WIRING DIAGRAMS

ECAI – MultiDNet electrical module

iii.1

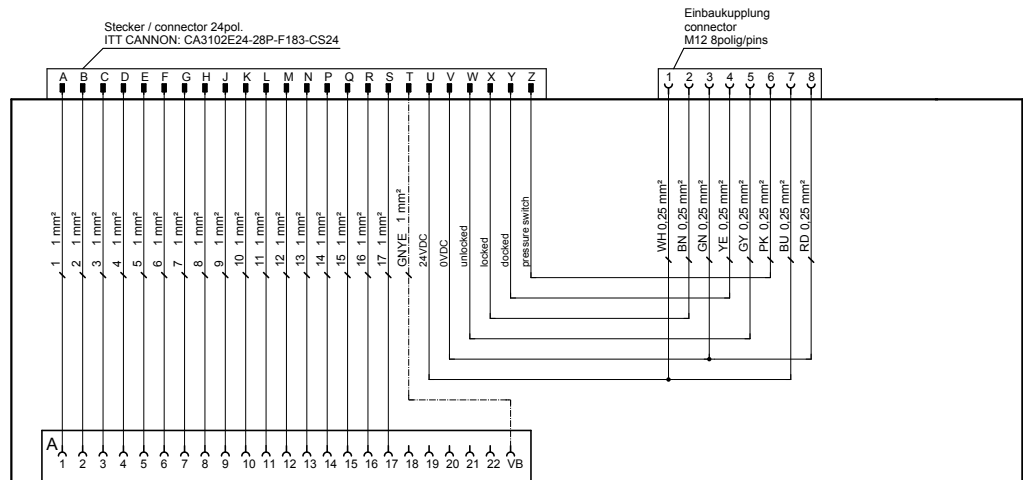

iii.2

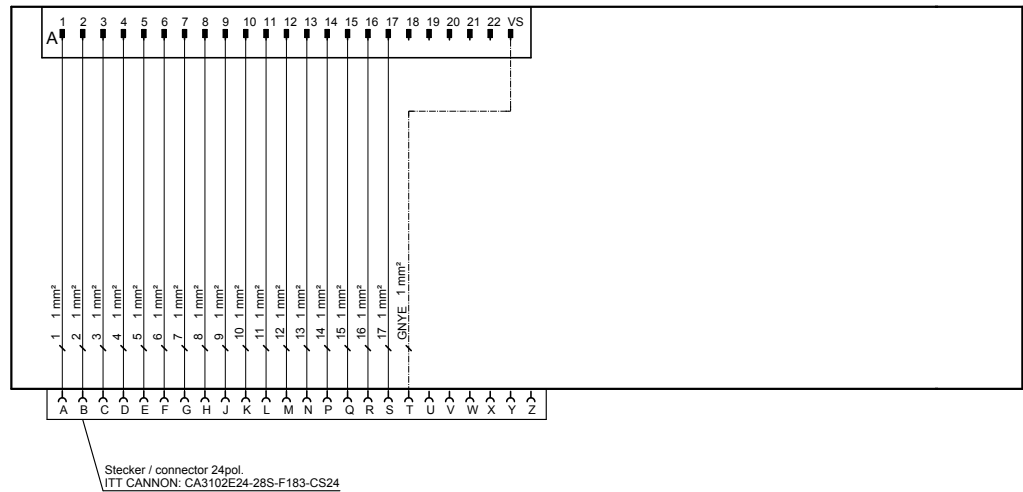

Depending on the connection cable used, the max. number of poles that can be assigned may be reduced when assembling the connection plug. The connection cables are not included in the scope of delivery.

ECAL – MultiDNet electrical module

iii.3

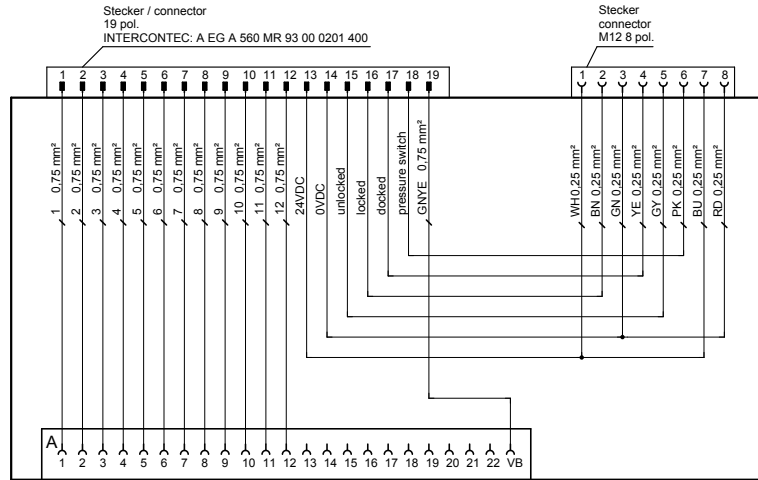

iii.4

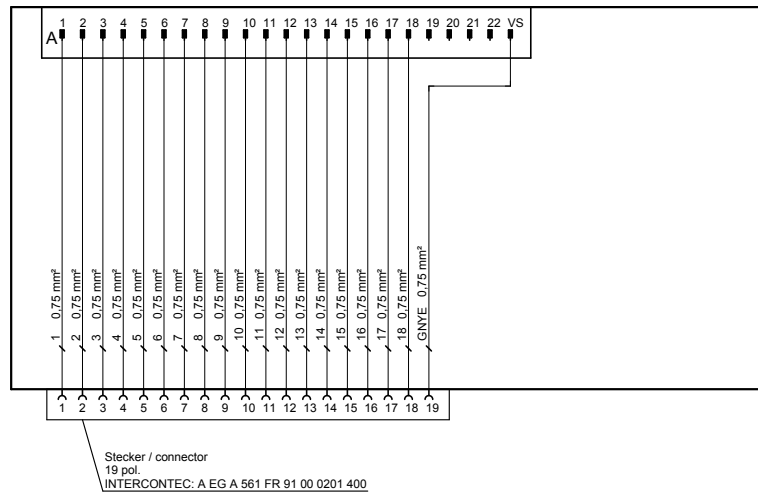

WIRING DIAGRAMS

ECAM – MultiDNet electrical module

iii.5

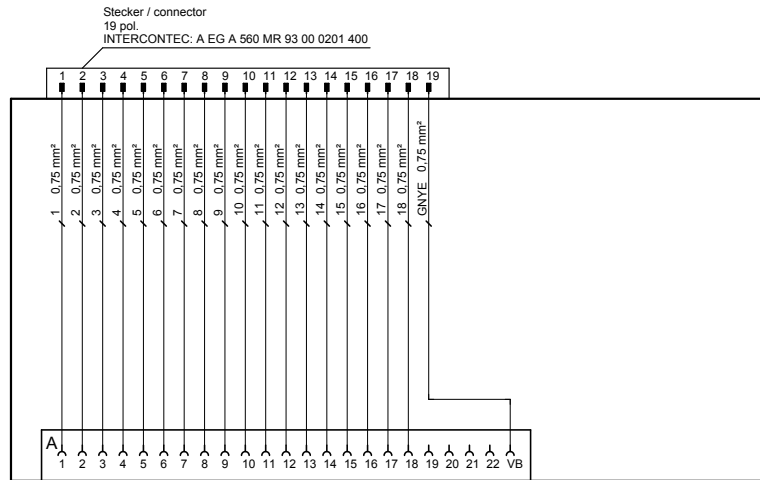

iii.6

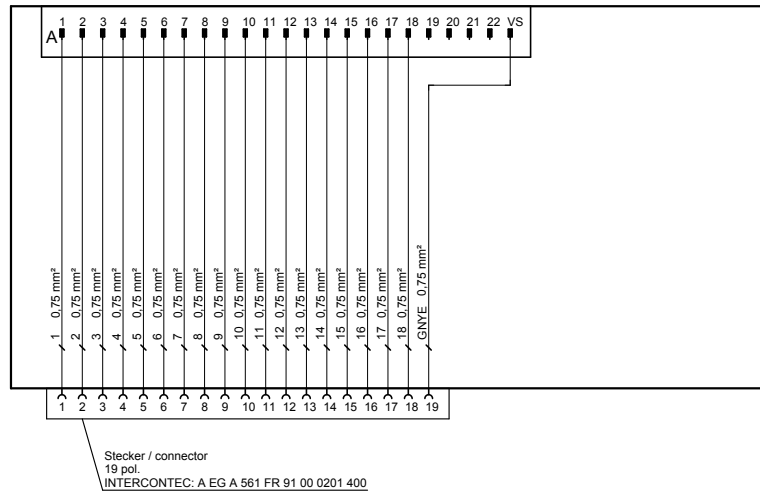

ECAB, ECAE – MultiDNet electrical module

iii.7+9

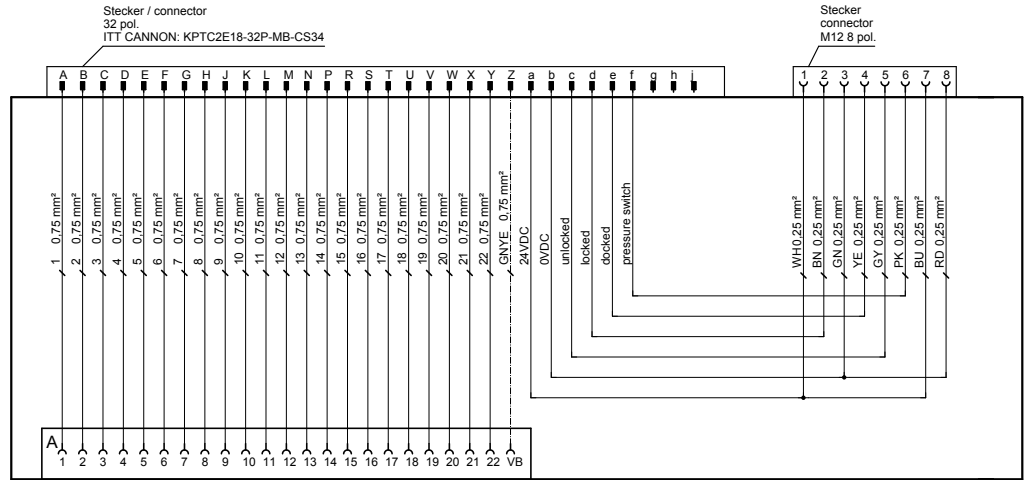

iii.8+10

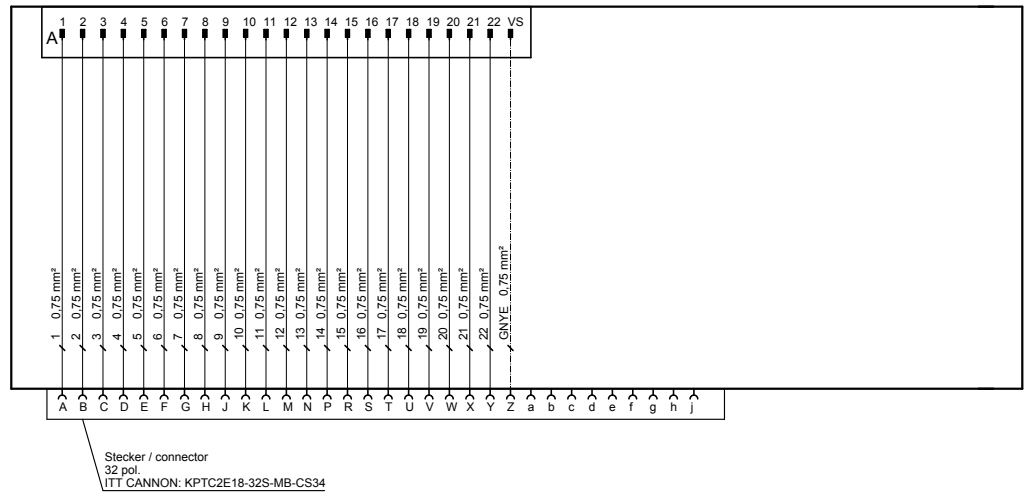

WIRING DIAGRAMS

ECAA, ECAD – MultiDNet electrical module

iii.1

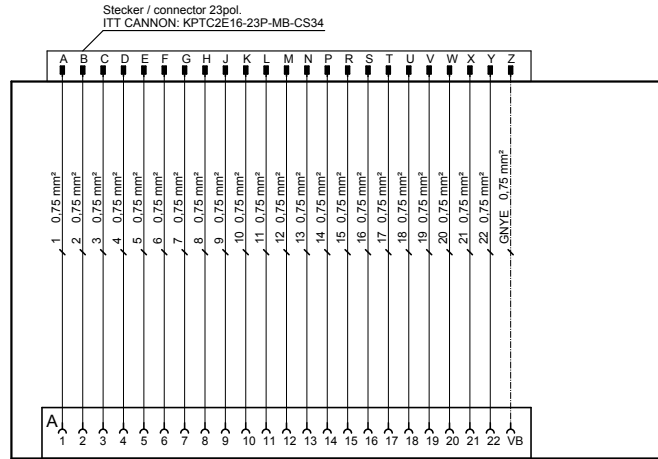

iii.2

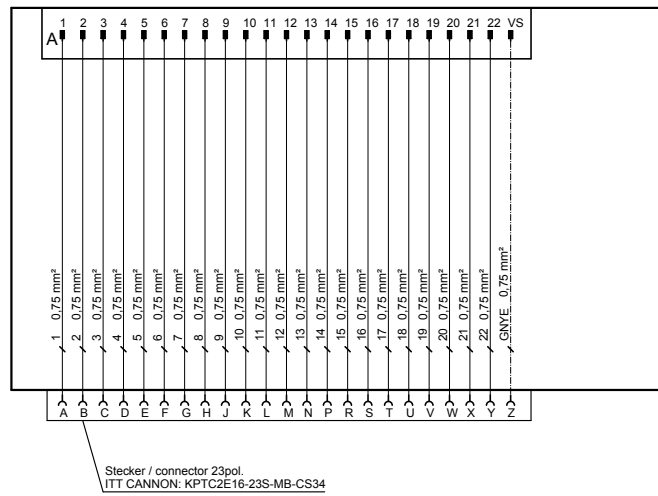

iii.3

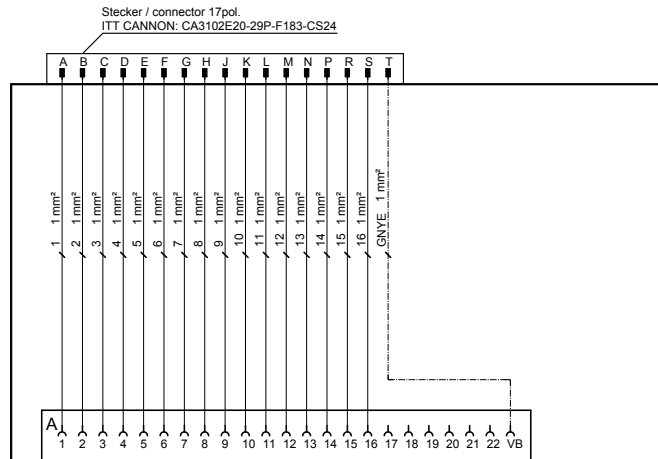

iii.4

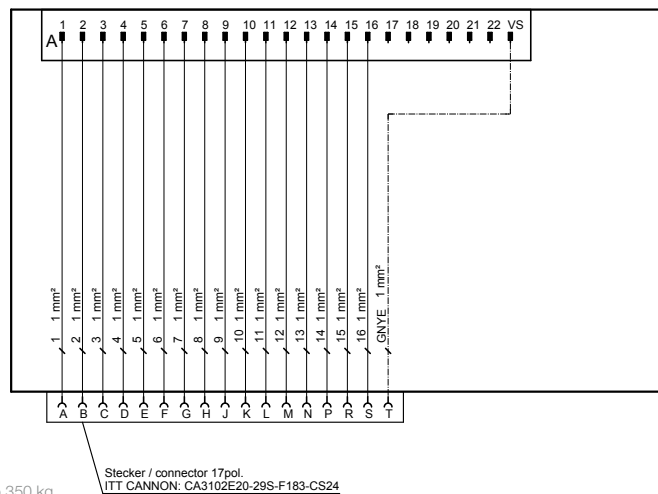

ECAC, ECAF – MultiDNet electrical module

ill.1

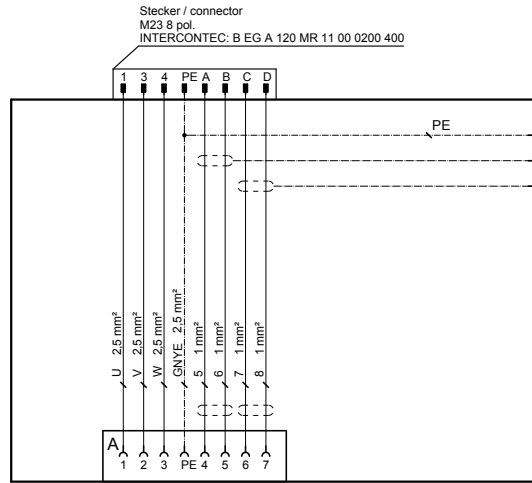

ill.2

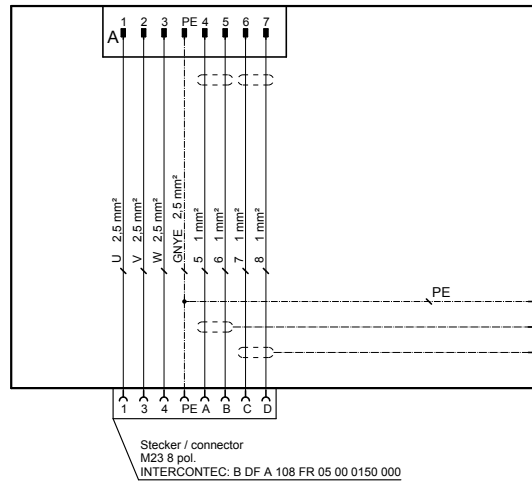

ill..3

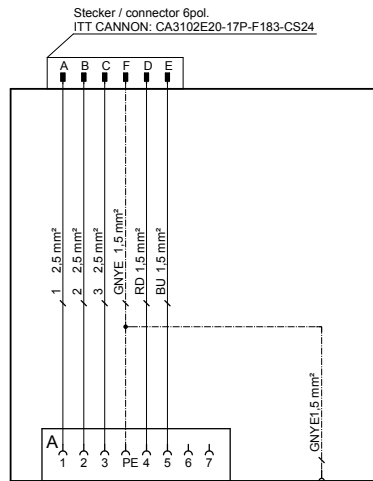

ill.4

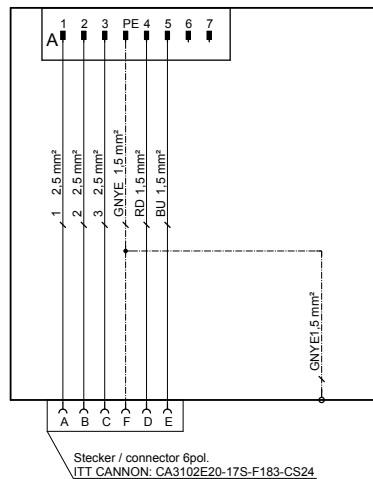



● Stäubli Units ○ Representatives/Agents

Global presence of the Stäubli Group

www.staubli.com