

FAST MOVING TECHNOLOGY

STÄUBLI

MPS

Robotic tool changing systems for payloads up to 2500 kg

Productivity for all industrial sectors





Table of contents

MPS CUSTOMIZED	3	PAYLOAD OVERVIEW	15
QUICK CHANGE TECHNOLOGY		MPS CUSTOMIZED	16
MPS 1530	4	MPS 1530	16
MPS 2531	6	MPS 2531	18
MPS SOLUTION COMPETENCE		MPS 1530 / 2531 TRANSFER MODULES	20
Multi-functionality for diverse technology	8	RMK transfer modules for pneumatics	20
Powerful base unit – high precision locking	9	FTM transfer modules for pneumatics and vacuum	20
Certified safety technology for people and facilities	10	SPM transfer modules for liquids and pneumatics	21
Millions of docking cycles – with minimum wear	11	SPC transfer modules for hydraulics	21
Stäubli's global competence and local presence	12	Fiber optic cable transfer modules for optical signals	22
100% Stäubli performance	13	MTM transfer modules for material feedthrough	22
From robot performance data to system selection	14	Transfer modules for tool coding	22
		Ground pin module for lubrication and grounding	23
		Primary circuit module MGK4 for welding current transmission	23
		Integrated IDA bus module for condition monitoring	24
		MultiIDNet-R G1 and G3 electrical modules	
		MultiIDNet G1 and G4 electrical modules	
		Active docking safety modules	26
		MPS 1530 / 2531 ACCESSORIES	27

R Base unit
robot side

T Base unit
tool side

 **Process safety**
maximum process safety for
equipment and personnel

 **Flexibility**
for maximum function diversity in
robotic manufacturing processes

 **Economic efficiency**
for cost-effective and sustainable
production processes

 **Productivity**
for innovative and quality-optimized
production processes

MPS CUSTOMIZED

Especially for your requirements



Highest fitting precision due to precise production



Specialist know-how from design to the finished solution



Stäubli MPS robotic tool changer systems have stood for the highest precision and quality standards combined with maximum safety for decades. Innovative, sustainable and variable technologies guarantee a long service life.

All systems in the MPS 1530 and MPS 2531 range are designed specifically according to your individual requirements:

- Base units, transfer and safety modules are optimized for the applications.
- You receive a system that is perfectly tailored to your requirements with regard to all performance data, material qualities and connection options.
- Individual customer-specific docking station on request.

MPS 1530 and MPS 2531 robotic tool changer systems are developed, produced and tested completely by Stäubli.

Optimized adjustment options over a long service life

The open product architecture of the modularly-designed range guarantees optimized adjustment to your application: now and in the future. If the requirements change, the systems can be adjusted again by relocating or replacing the transfer modules.

Thanks to Stäubli's decades of expertise and wide range of products in the transfer module and electrical plug connection areas, high flexibility is guaranteed.



Comprehensive payload ranges

Stäubli supplies a comprehensive payload range of 10 to 2500 kilograms for a wide range of applications. Please contact us if the payloads specified here do not meet your requirements.

www.staubli.com

Best productivity in narrow spaces

MPS 1530 and MPS 2531 robotic tool changer systems are also the ideal solution for high payload requirements in very narrow spaces.

Both the particularly compact design of base units and transfer modules, and the flexible module positions make work areas that could not be reached by other systems accessible.



QUICK CHANGE TECHNOLOGY

MPS 1530 – robot and tool side

R Base unit
robot side

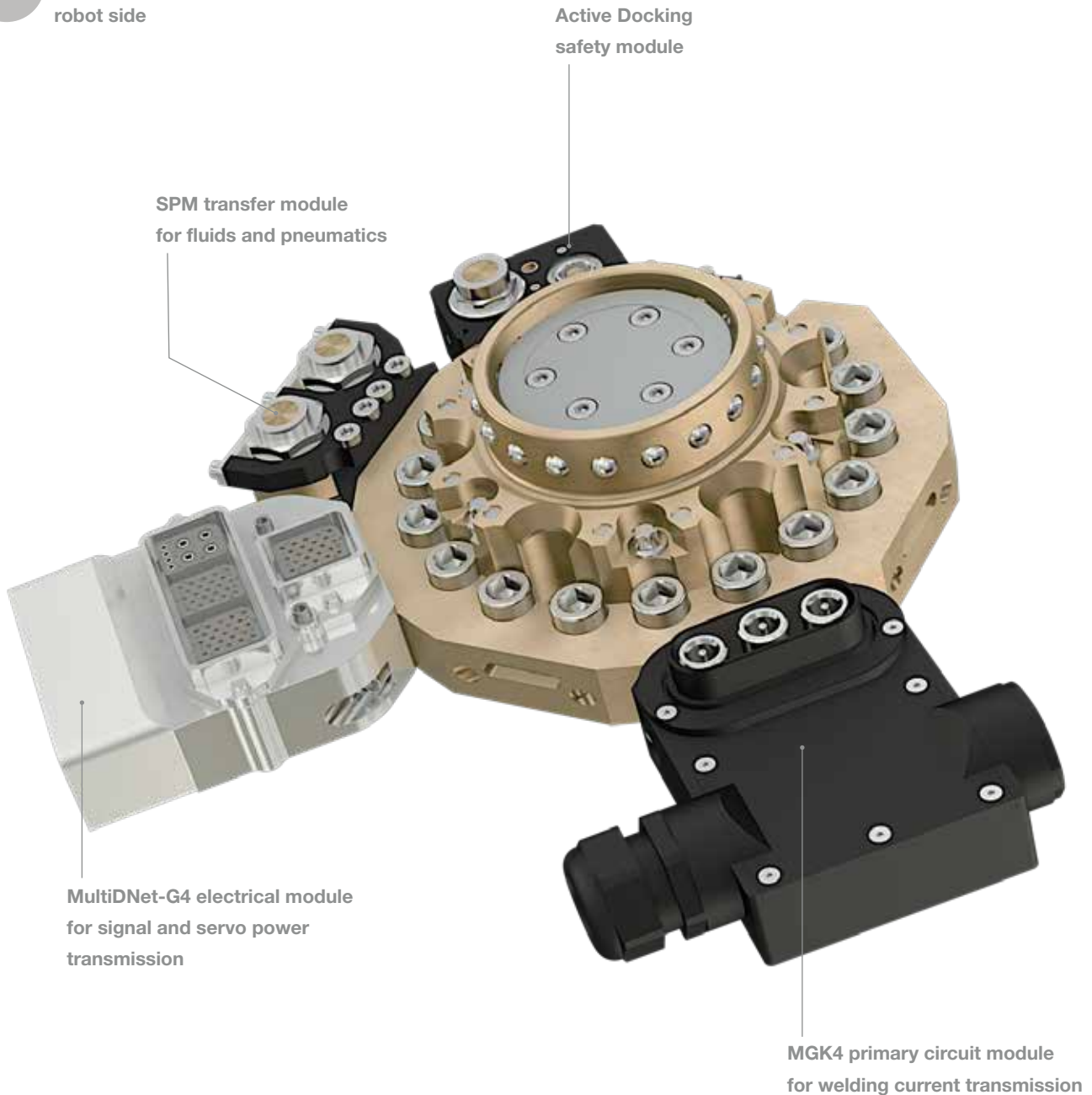



Base unit
tool side

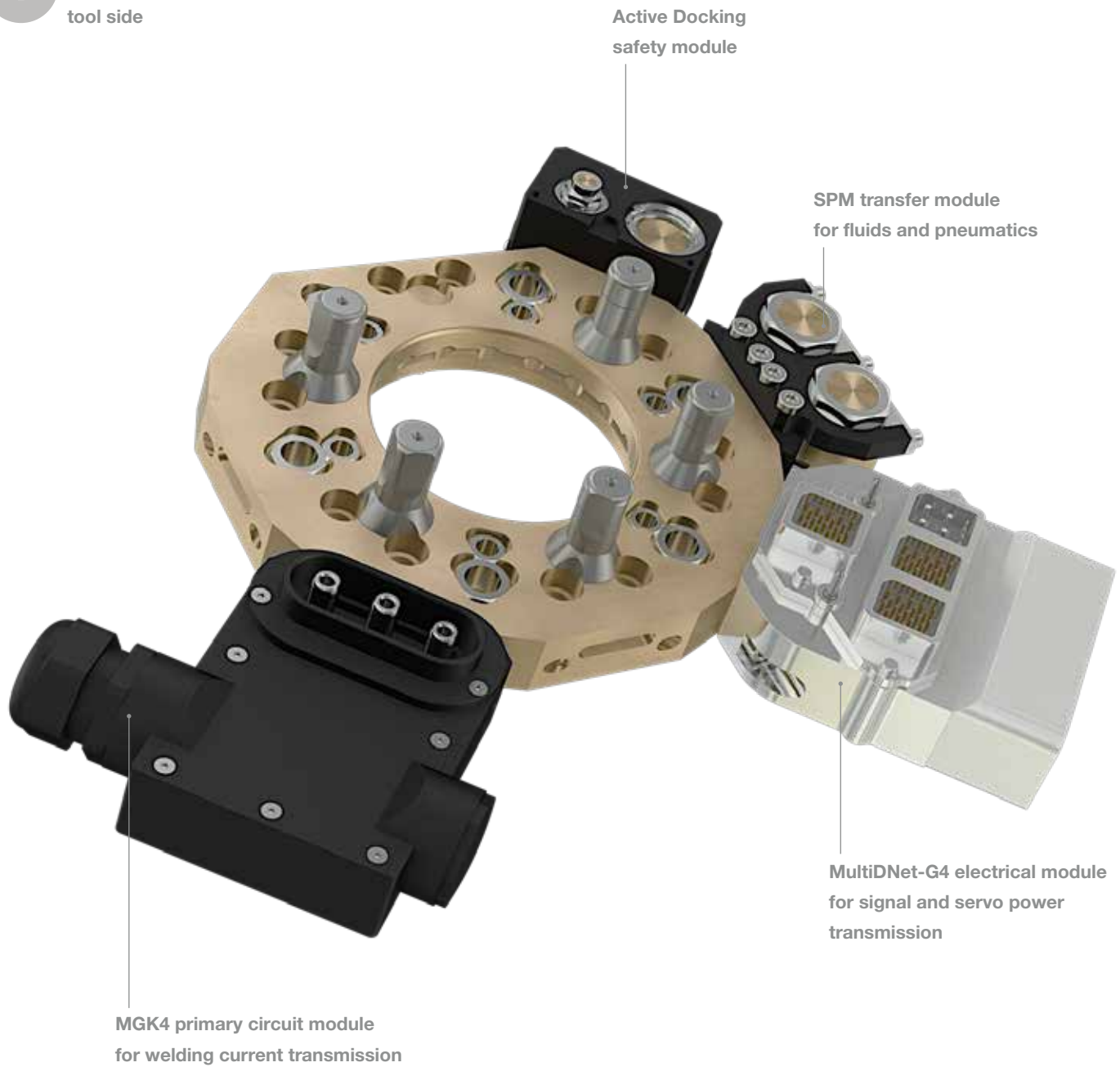

QUICK CHANGE TECHNOLOGY

MPS 2531 – robot and tool side

R Base unit
robot side





Base unit
tool side

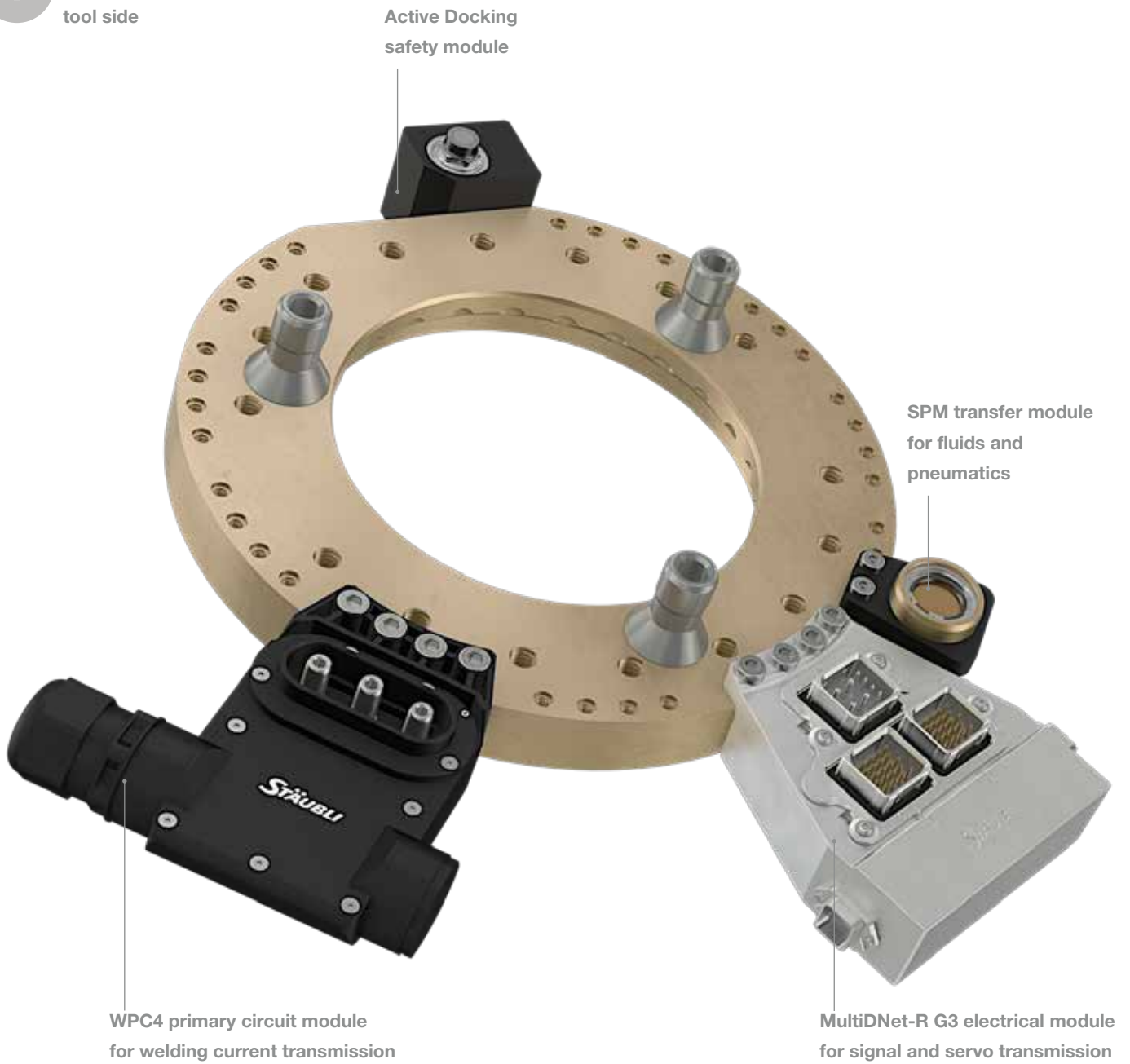

Active Docking
safety module

SPM transfer module
for fluids and
pneumatics

WPC4 primary circuit module
for welding current transmission

MultiDNet-R G3 electrical module
for signal and servo transmission

Multi-functionality for diverse technology

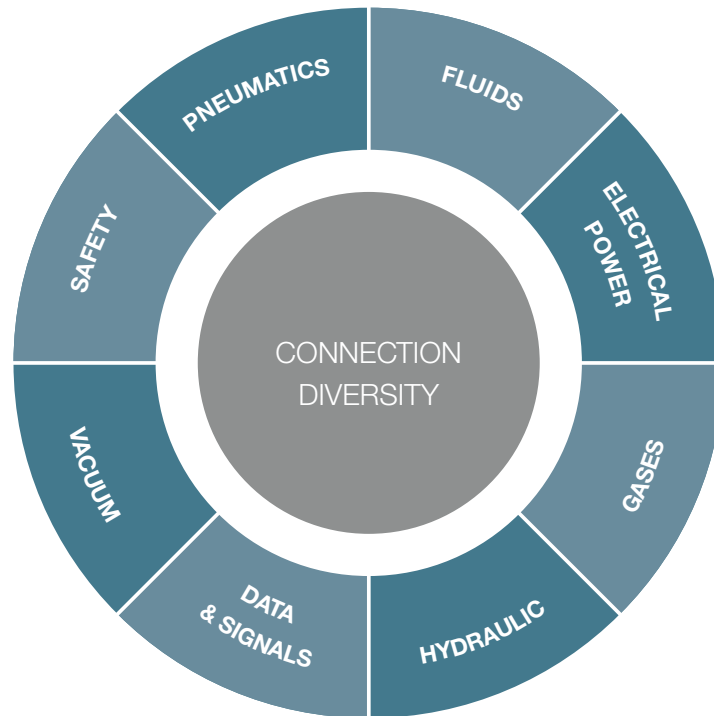

Stäubli MPS systems can be equipped with a wide range of transfer modules for different applications. This multifunctional design maximizes production efficiency, covering the entire spectrum of industrial robot applications. The Stäubli MPS systems incorporate more than 60 years of expertise in coupling technology for electrical and fluid media, utilizing the full potential of robotic production technology.

The basic units on the robot and tool side are circular in design maximizing flexibility when equipping the tool changer system with a variety of transfer modules.



Flexibility

Robot versatility is guaranteed because of the diverse modules. Energy and data transfer can be added to the robotic tool changing systems at any time. As a pioneer in coupling technology with decades of experience, Stäubli can also design individual coupling and connection solutions for specific requirements.



Productivity

Stäubli robotic tool changers provide flexible technology and productivity in a wide range of applications: from simple handling applications to various welding methods, punch riveting, screwing, gluing, and material transfer.

Powerful base unit – high precision locking

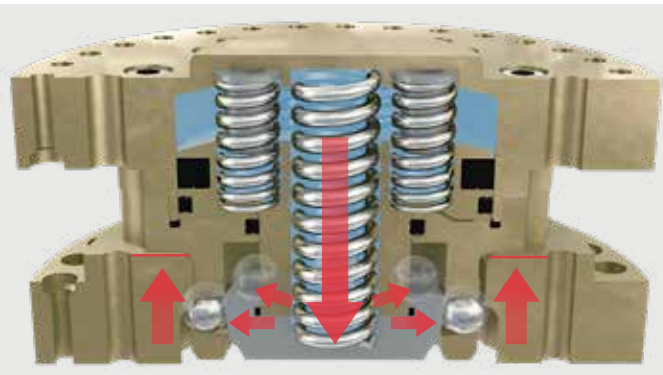

Powerful and precise locking for safe and error-free processes



Highest positioning precision due to precise ball locking

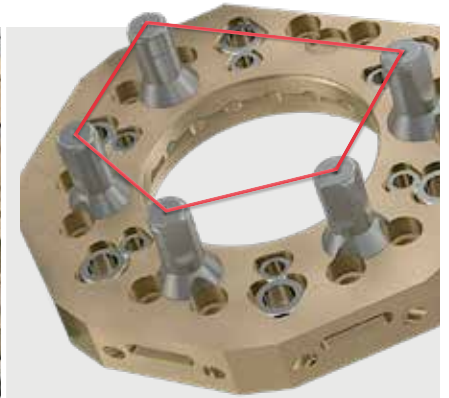

Exact fusion due to conical guide columns

Stäubli tool changing systems ensure high-precision connection between the robot and the tool. The intelligent design of the robotic tool changer ensures absolute precision and a long service life.

The robot and tool side are pre-aligned and brought together via three guide columns. The conical locking surfaces ensure exact positioning between the two sides of the MPS tool changing system. A large volume of high-strength locking balls maintain the friction lock between robot and tool.

Individual docking unit solutions can be developed for your requirements on request.



Process safety

Your company benefits from precise repeatability in the changer system (± 0.01 mm for each axis). Even if there is a high number of changing cycles, the tools are moved to their 100 percent exact usage position.



Economic efficiency

Due to the high-precision locking even extremely bulky tools can be precisely positioned as defined by the manufacturing process, guaranteeing consistent product quality.



Productivity

The lock is designed for an extremely high number of change cycles. This guarantees permanent precision and maximizes production output.

Certified safety technology for people and facilities



Personnel and plant safety is essential in automated processes. Manufacturers and operators of robots and robotic devices have to ensure compliance with the ISO 10218-2 standard. Stäubli robotic tool changers satisfy the demanding requirements of “Performance Level d, Category 3”. The safety concept for the Stäubli MPS systems provides reliable protection for operators and safeguards process quality.

This MPS system safety level can either be achieved by electromechanical transponder technology or with the Active Docking System developed by Stäubli.

Both are integral aspects of the product concept. The **transponder option** consists of a safety switch in combination with the Stäubli ISB 200 logic module acting as a bus system-independent safety circuit.

The **Active Docking System** is a proprietary development by Stäubli. The compressed air supply for the decoupling process is provided as an individual circuit that is only available in the tool stand. This means that the tool can only be unlocked at the tool stand. Once the robot has picked up a tool it cannot be accidentally unlocked because there is no connection to the compressed air supply.



Process safety

Maximum safety of robot systems operators and automated tool change processes are guaranteed.

Millions of docking cycles – with minimum wear

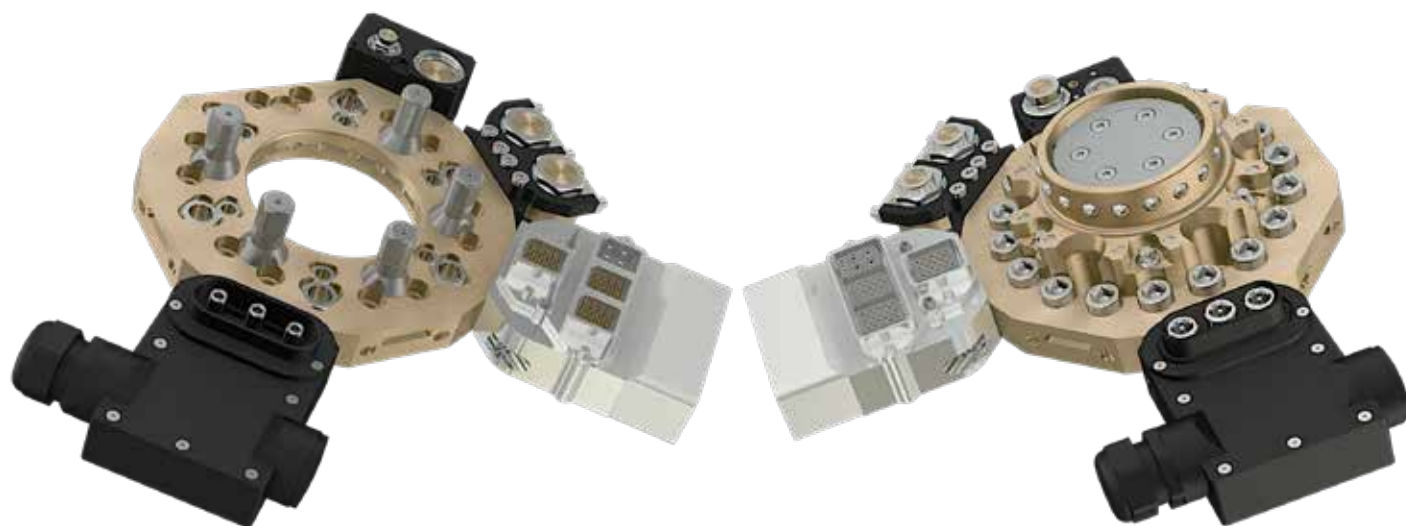

All the media couplings and electrical connectors integrated in the modules feature floating contact technology. This reduces wear to a minimum, ensuring a precise and reliable connection even after millions of docking cycles. For maintenance purposes, parts can be replaced quickly with minimal interruption to the robot work-flow.

Transfer modules and connectors can be replaced directly on the MPS system without the need to disassemble the tool

changer, or to disconnect cables and hoses. This allows entire modules to be replaced quickly and easily. A cartridge system (Quick Change Inserts) makes it possible to replace worn parts directly in the modules.



Process safety

Floating contact technology allows the plug and socket for fluid connectors and the pins and socket for electrical connectors to align. This ensures perfect connection of both fluid and electrical connections.



Economic efficiency

The long life of Stäubli components guarantees a reliable coupling processes even after millions of docking cycles. Long maintenance intervals reduce downtime, as well as repair and replacement part costs.



Productivity

The service-friendly design of the transfer modules, as well as the integrated media couplings and electrical connectors, ensure maintenance time is minimal.

Stäubli's global competence and local presence



Stäubli has subsidiaries at major industrial hubs around the world. Their experienced engineers have detailed, product-specific know-how and application expertise to provide the highest quality of advice to customers and guarantee fast response times worldwide.

Robotic tool changers are variable systems that have to be efficiently integrated into production processes, therefore advice to customers on the correct basic and special configurations, adaptations, and optimizations is essential. Our global warehousing concept ensures that components and spare parts are quickly delivered to customers around the world.



Flexibility

Users receive solutions that comply with all country-specific guidelines and standards. The robotic tool changing systems are adapted to national industrial norms, such as thread standards or information retrieval technologies in sensor systems. Thanks to our global network, customers can easily implement multi-national production concepts.



Productivity

Wherever your company is in the world, users can receive a specialist's advice on applications. This guarantees the best possible implementation of the tool changing processes on robot lines at any

production site. Customers have access to our global know-how, so that they can maximize the productivity of new plants and achieve optimum results in retrofit and maintenance situations.



Economic efficiency

Single point of contact: we designate one customer consultant to the company for the entire duration of the project. This makes the cooperation more efficient and reduces the complexity of project coordination and implementation. Customers also benefit from our consulting expertise directly at their premises when implementing or installing the tool changing systems.

100% Stäubli performance

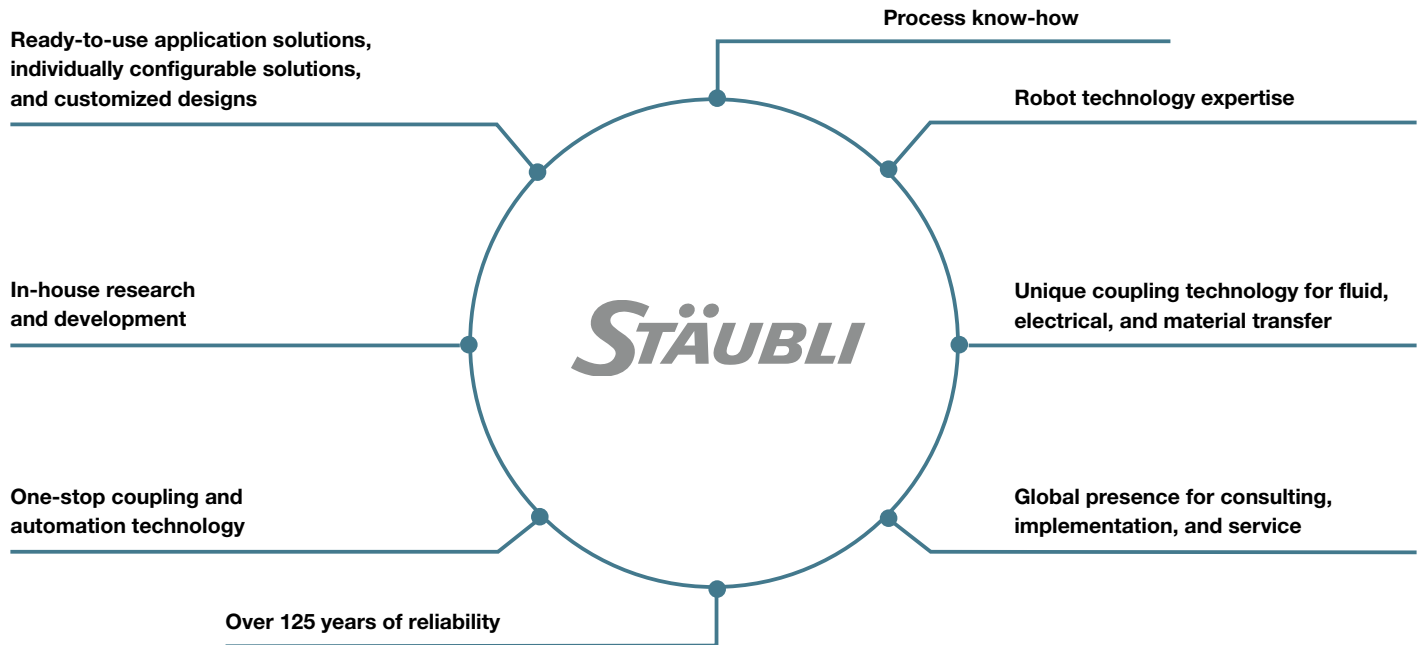

All the components of the Stäubli MPS systems come from a single source and are perfectly harmonized. Stäubli performance is 100% based on a combination of products, expertise and know-how.

All individual components – from base unit to transfer module – are developed and manufactured by Stäubli. Stäubli prides itself on being an all-encompassing single supplier, and is responsible for the entire MPS system. Our customers can count on us supporting them with our expertise and experience.



Process safety

You have the assurance of integrating well-engineered and comprehensively tested robotic tool changers into your production line. All systems and components are designed and manufactured by Stäubli to the highest industrial standards, supporting you with our process analysis and optimization know-how.



Flexibility

The robot tool change systems from Stäubli enable simple application-specific module and component configuration. The unique assembly con-

cept of the MPS systems allows adaptation to new or changed conditions at any time.



Economic efficiency

With over 60 years of experience as a global manufacturer in coupling technology for media and power connections, Stäubli delivers unprecedented performance and longevity. Component compatibility is guaranteed – ensuring risk free investment.

From robot performance data to system selection

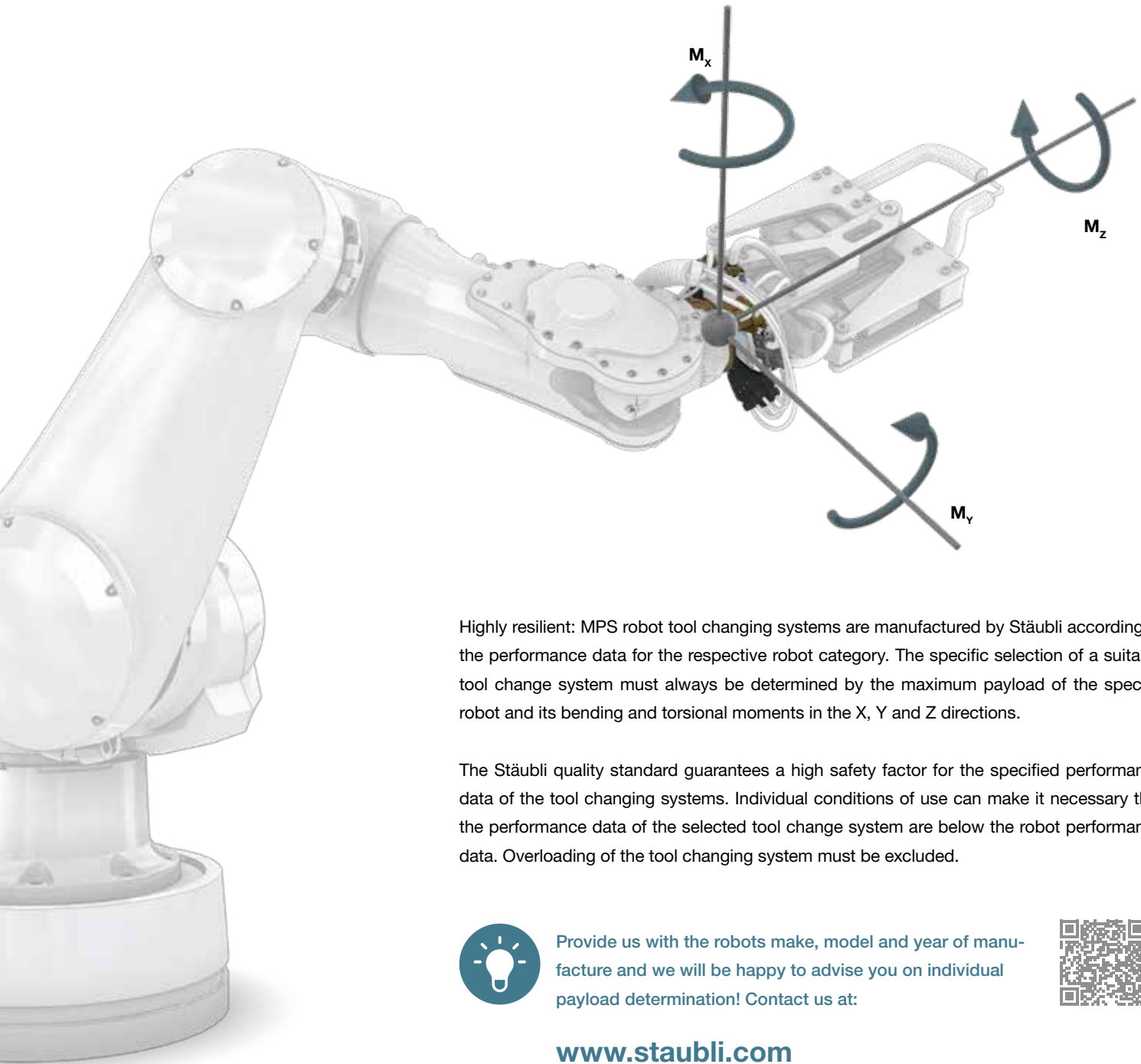

Highly resilient: MPS robot tool changing systems are manufactured by Stäubli according to the performance data for the respective robot category. The specific selection of a suitable tool change system must always be determined by the maximum payload of the specific robot and its bending and torsional moments in the X, Y and Z directions.

The Stäubli quality standard guarantees a high safety factor for the specified performance data of the tool changing systems. Individual conditions of use can make it necessary that the performance data of the selected tool change system are below the robot performance data. Overloading of the tool changing system must be excluded.



Provide us with the robots make, model and year of manufacture and we will be happy to advise you on individual payload determination! Contact us at:



www.staubli.com

PAYLOAD OVERVIEW

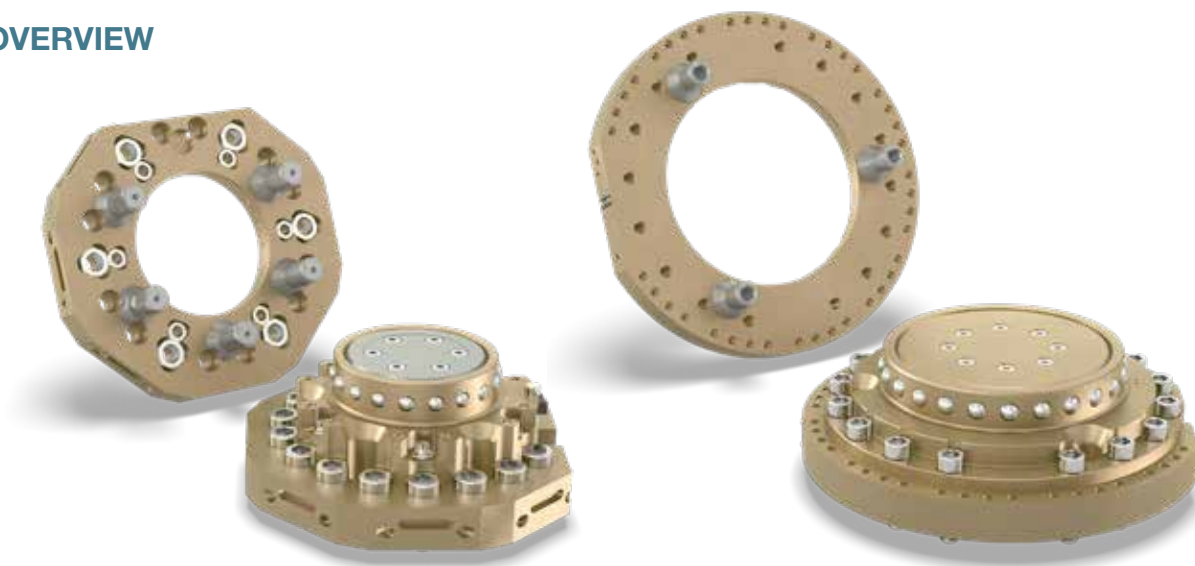

	MPS 1530		MPS 2531	
	M_x / M_y	M_z	M_x / M_y	M_z
max. static moment*	12500 Nm	12500 Nm	44000 Nm	33000 Nm
max. dynamic moment*	43750 Nm	43750 Nm	110000 Nm	66000 Nm
max. payload	1530 kg		2500 kg	
max. repulsion force	100 kN		160 kN	
max. connection force	200 kN		320 kN	
max. lateral force	100 kN		160 kN	
Pitch circle diameter (PCD) robot adapter flange	ISO 9409-1-200-16-M16 ISO 9409-1-200-6-M12		ISO 9409-1-315-16-M16	
Height (coupled)	100 mm		110 mm	
Weight - robot side	12.5 kg		30.1 kg	
Weight - tool side	8.8 kg		20.5 kg	
Compressed air connection	2 x G1/8 female thread		2 x G1/8 female thread	
Pneumatic ball locking	0.45 - 1.2 MPa 5 NI / cycle at 0.6 MPa		0.45 - 0.8 MPa 11 NI / cycle at 0.6 MPa	
Repeatability	+/- 0.01 mm		+/- 0.01 mm	
Number of module sockets	7		10	
Query	locked / unlocked / coupled		locked / unlocked / coupled	
Emergency release	yes		yes	
Safety in case of drive medium failure	yes, by compression spring		yes, by compression spring	

* Due to their potentially high acceleration, robots can generate dynamic moments that are several times higher than static moments. The dynamic moments can occur in an emergency stop situation of the robot. Since they occur only very rarely during the robot's lifetime a static proof of strength is usually sufficient for this purpose.



Check out our comprehensive MPS range. Contact us for other payloads and special designs.



www.staubli.com

MPS 1530 CUSTOMIZED

MPS 1530

Dimensions

R

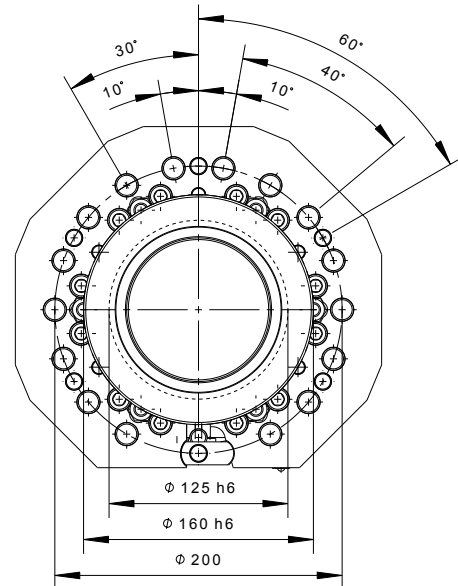
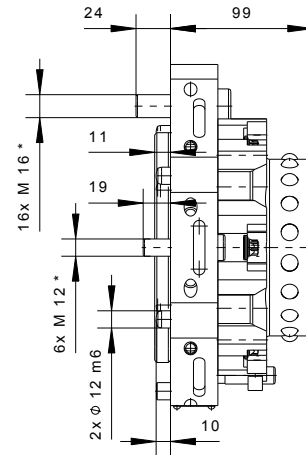
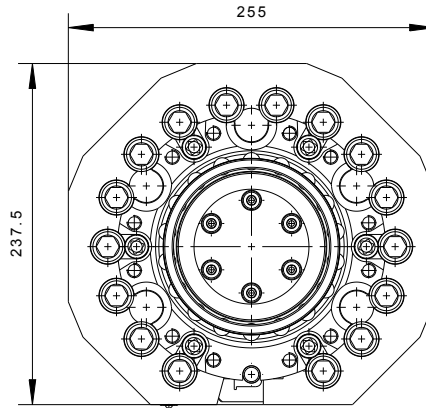
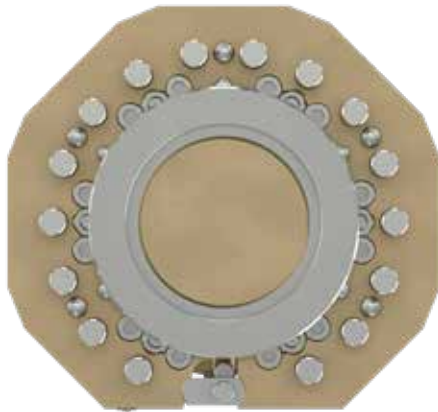

* The robot side MPS 1530 provides two fastening options.
16x M16 or 6x M12 for reduced payload. Please observe the technical data in the operating instructions.

T

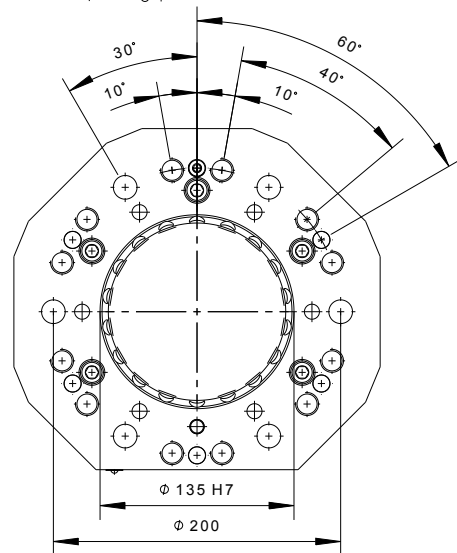
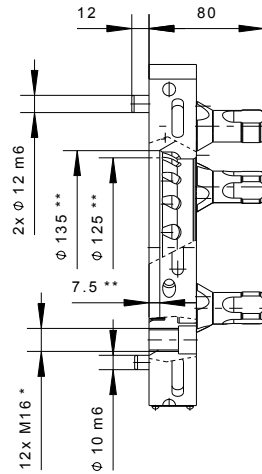
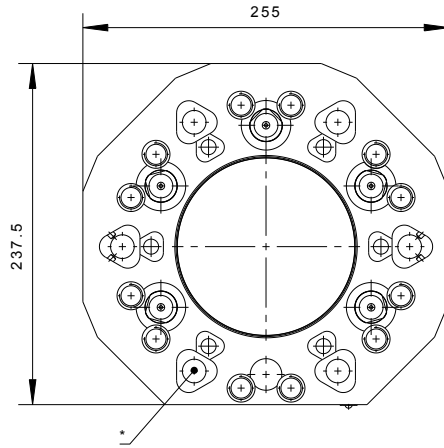
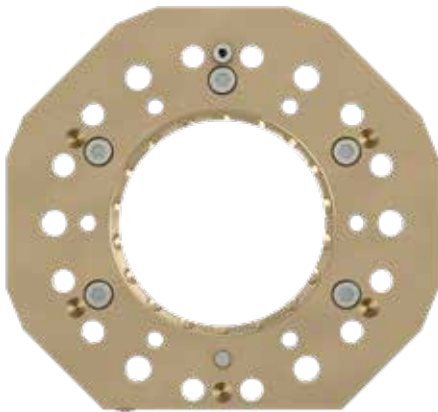

MPS 2531 CUSTOMIZED

MPS 2531

Dimensions

R

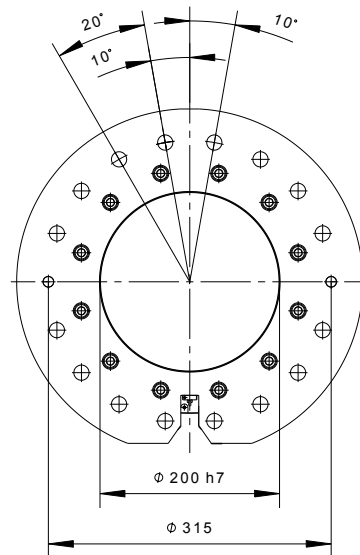
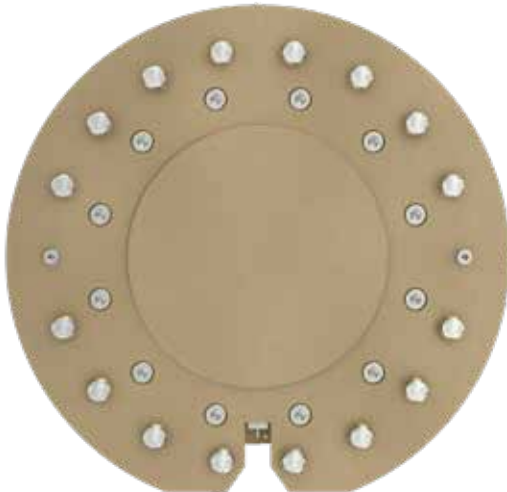
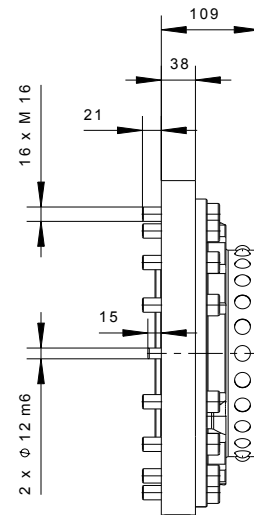
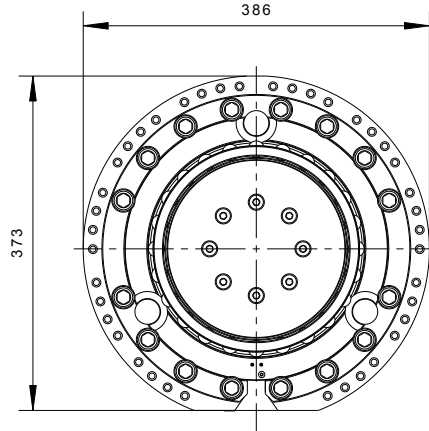
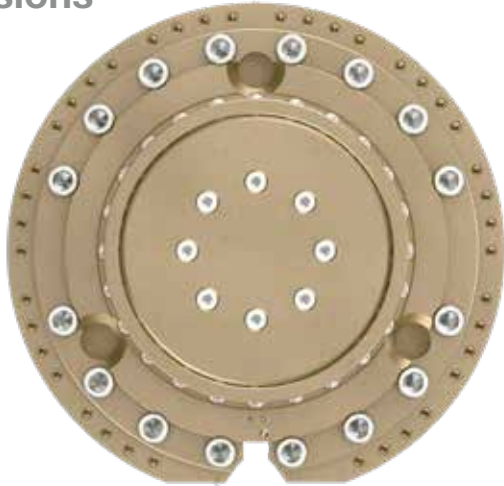

T

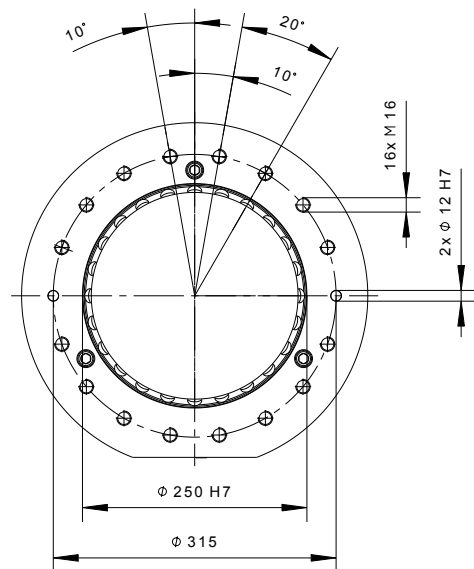
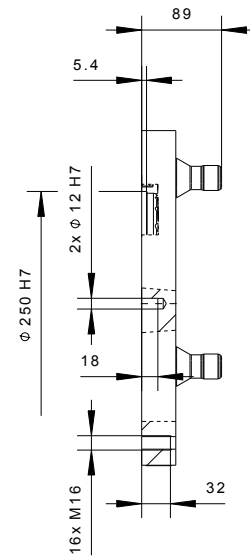
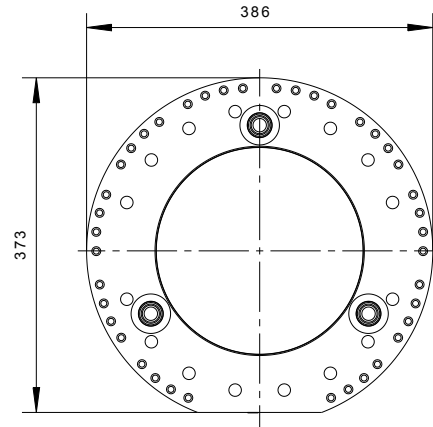
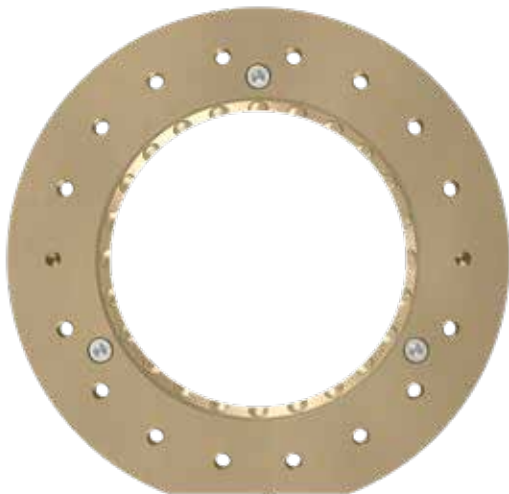
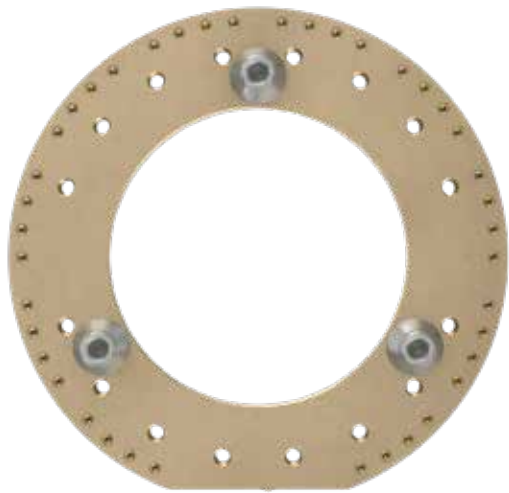

MPS 1530 / 2531 TRANSFER MODULES

Transfer modules for your production technologies

RMK transfer modules for pneumatic system

Technical description

- quick and simple replacement of the couplings during servicing
- large volumetric flows, low flow resistance
- extremely robust design guarantees a high number of plug cycles

	Nominal width	Circuits	Valve	Pressure (max.)	Flow rate
R	6 mm	2	Single-sided	1.0 MPa	25 Nm ³ /h
T			Free passage		
R	11 mm	1	Single-sided	1.0 MPa	40 Nm ³ /h
T			Free passage		



FTM transfer modules for pneumatic system and vacuum

Technical description

- free passage guarantees large volumetric flows with low flow resistance
- suitable for transferring up to 90% vacuum
- extremely robust design guarantees a high number of plug cycles

	Nominal width	Circuits	Valve	Pressure (max.)	Flow rate
R	5.5 mm	5	Free passage	1.0 Mpa	37 Nm ³ /h
T					
R	6 mm	3	Free passage	1.0 Mpa	44 Nm ³ /h
T					
R	11 mm	1	Free passage	1.0 Mpa	215 Nm ³ /h
T					



SPM transfer modules for liquids and pneumatic system

Technical description

- clean-break technology for safe, leak-free media transfer
- no workplace contamination, no air entering into the media circuit
- quick-change system for quick and easy servicing
- large volumetric flows, low flow resistance

	Nominal width	Circuits	Valve	Pressure (max.)	Flow rate	Connection
R	12 mm	1	Both sides clean-break	1.6 MPa	40 l/min*	G1/2, NPT 1/2, Rc 1/2 female thread
T						

* For liquids at 5 m/s, ** For gases.



SPC transfer modules for hydraulics

Technical description

- clean-break technology for safe, leak-free media transfer
- no workplace contamination, no air entering into the media circuit
- quick-change system for quick and easy servicing
- large volumetric flows, low flow resistance

	Nominal width	Circuits	Valve	Pressure* (max.)	Flow rate** (max.)	Connection
R	8 mm	1	Both sides clean-break	25 MPa	15 l/min	G 3/8, NPT 3/8, Rc 3/8 female thread
T						

* The simultaneously occurring maximum pressure load of the coupled tool change system does not exceed 25 MPa.

** Vmax. = 5 m/s; Cv=2,14.



HVA transfer modules for hydraulics

Technical description

- connection modules with clean-break design
- no workplace contamination, no air entering into the circuit
- quick-change system for quick and easy connection replacement during servicing
- force de-coupling of the hoses
- flat overall height
- large volumetric flows, low flow resistance

	Nominal width	Circuits	Valve	Pressure* (max.)	Flow rate** (max.)	Connection
R	9 mm	2	Both sides clean-break	25 MPa	114.5 l/min	G 3/8, NPT 3/8, Rc 3/8 female thread
T						

* The simultaneously occurring maximum pressure load of the coupled tool change system does not exceed 25 MPa.

** Vmax. = 30 m/s; Cv=3,18.



MPS 1530 / 2531 TRANSFER MODULES

Fiber optic cable transfer modules for optical signals

Technical description

- signal transfer via lens technology
- insensitive to offset and axis deviation
- automatic protective cover for the lenses
- protection of the individual wires thanks to robust connection housing
- identical parts for both base units
- extremely low damping factor

	Cable type	Connection
R	Duplex 1000 µm, polymer fiber cable 980/1000	2x FSMA
T		



MTM transfer modules for material feedthrough

Technical description

- possible transfer materials: Screws, threaded bolts and rivets
- individual designs according to the manufacturer-specific transfer applications

Transfer modules for tool coding

Technical description

- individual coding for tool sides
- four inductive proximity switches on the robot side
- mechanical adjustment of the coding using an adjustment screw on the tool side

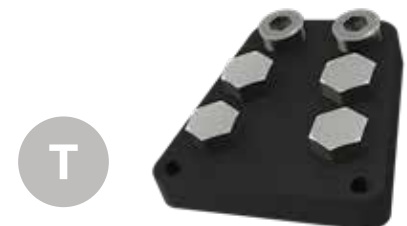

Ground pin module for lubrication and grounding

Technical description

- excellent power transfer thanks to patented Stäubli-MULTILAM technology
- floating contact mountings guarantee wear-free connection processes
- low tare weight

	Transmission poles	Voltage/current or design	Cable cross-section	Connection
R	1	55 VAC / 75 A	10 mm ²	Crimp sleeve
T	1	55 VAC / 235 A	70 mm ²	
R	1	55 VAC / 262 A	95 mm ²	



Primary circuit module WPC4 and MGK4 for welding current transmission

Technical description

- excellent power transfer thanks to patented Stäubli-MULTILAM technology
- suitable for high-frequency transfers of up to 10 kHz when using HF lines
- floating contact mountings guarantee wear-free connection processes
- protection class: IP 65 (when connected)

	Transmission poles	Voltage/current or design	Cable cross-section	Threaded joint	Clamping range
R	2+PE	1000 VAC 135 A / 150 A	25 mm ² /35 mm ²	M40x 1.5	19-28 mm
T	2+PE	1000 VAC 135 A / 150 A / 200 A	25 mm ² /35 mm ² / 50 mm ²	M50x 1.5	21-35 mm



MPS 1530 / 2531 TRANSFER MODULES

Integrated IDA bus module for condition monitoring

The integrated IDA bus module is an I/O module housed in the MultiDNet-R electrical module. IDA enables a space-saving and functional connection of the condition monitoring to the robotic tool changing system as well as to the higher control level.

Easy-to-read LED status displays and convenient configuration via a web server further simplify the use of the IDA.

An integrated power cut-off module for the 24V power supply prevents contact wear without any programming effort.

Technical description

- compact design
- compatible with Modbus TCP, Ethernet/ IP and ProfiNet
- LED lights for operating states
- configuration via web server
- integrated 6-bit tool coding

	Description	Connection
R	Integrated IDA bus module for system monitoring	7/8" 5-pin. M12-D coded
T		



MultiDNet-R G1 and G3 electrical modules for signal and servo transmission

Technical description

- one or three individually configurable contact chambers for signal and servo transmission
- excellent power transmission with patented Stäubli's MULTILAM technology
- malfunction-free and long-life contact technology
- protection class: IP 65 (in coupled state)
- excellent shielding technology for reliable data and power transmission
- optional quick-change system

	Type	Transmission poles	Voltage (max.)	Current (max.)	Applications
R T	Signal	22+PE	24 V	20 A	Ethernet, Interbus, Profibus, audio, video
R T	Servo	3+PE	690 V	32 A	Servo power transmission
R T		4	250 V	20 A	Brake, signals



MPS 1530 / 2531 TRANSFER MODULES

MultiDNet G1 and G4 electrical modules for signal and servo power transmission

Technical description

- one or four contact chambers that can be equipped individually for servo and signal transfer
- excellent power transfer thanks to patented Stäubli-MULTILAM technology
- fault-free and long-life contact technology
- protection class: IP 65 (when connected)
- superb shielding technology for safe data and power transfer
- quick-change system available as an option

	Type	Transmission poles	Voltage (max.)	Current (max.)	Applications
R T	Signal	22+PE	24 V	20A	Ethernet, Interbus, Profibus, audio, video
R T	Servo	3+PE	690 V	32A	Servo power transmission
R T		4	250 V	20A	Brake, signals

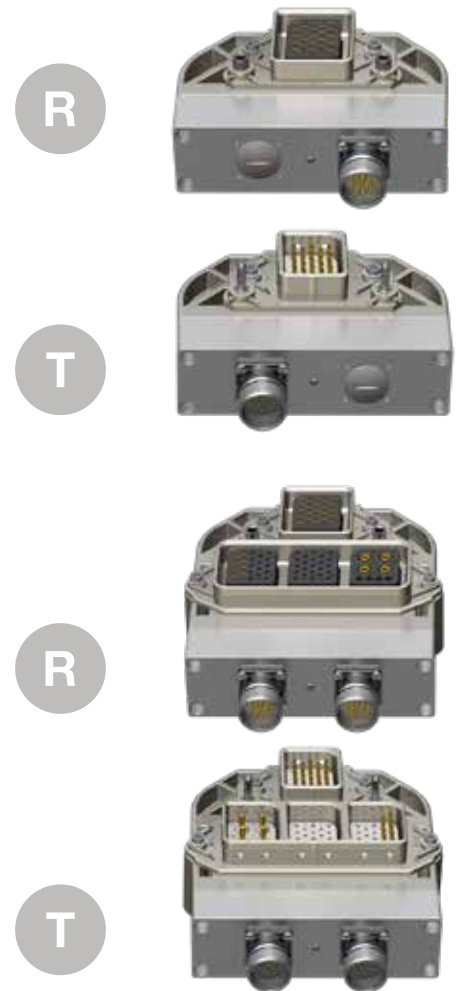

Active docking safety modules Performance level d, category 3

Technical description

- stand-alone system, independent of bus system
- easy integration, reduced system costs
- integrated pressure switch to monitor the locking pressure
- meets the safety requirements according to performance level d, category 3

	Sensor system/connection		Compressed air connection
R	Pressure switch 4.5 bar/NO	PNP/ 1x M12	G3/8 female thread
R	Pressure switch 4.5 bar/NO	NPN/ 1x M12	G3/8 female thread
T	No		Self-fastening hose outer Ø 8 mm

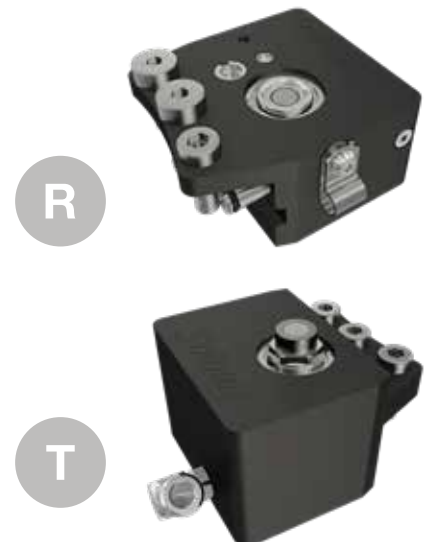

MPS 1530 / 2531 ACCESSORIES

MPS 1530 / 2531 Tool stand and accessories

Tool stand

Technical description

- tool stand for flexible assembly according to technical requirements



Teaching aid

Technical description

- teaching aid to teach the robotic tool changing system easily



Emergency release

Technical description

- tool for emergency release





● Staubli Units ○ Representatives/Agents

Global presence of the Staubli Group

www.staubli.com