

# MPS

## Robotic tool changing systems for Payload up to 630 kg

**Productivity for all industrial sectors**



# Table of contents

<b>System structure</b>	<b>4</b>	<b>MPS 631 COMPLETE</b>	<b>20</b>
		<b>MPS 631 MODULAR</b>	<b>26</b>
<b>Tool stand technology</b>	<b>5</b>	<b>MPS 631 Accessories</b>	<b>34</b>
<b>Quick change technology</b>	<b>6</b>	<b>MPS 631 TOOL STAND COMPLETE</b>	<b>37</b>
		<b>MPS 631 TOOL STAND MODULAR</b>	<b>42</b>
<b>MPS solution competence</b>	<b>8</b>		
Unique multifunctionality	8	<b>MPS 631 Transfer modules</b>	<b>48</b>
Needs-oriented modularity orientated	9	Transfer modules for pneumatics	50
Powerful base unit – high precision locking	10	Transfer modules for pneumatics and vacuum	52
Smart details – for perfect connections	11	Transfer modules for fluids and pneumatics	53
One system for all robots	12	Transfer modules for hydraulics	54
Certified safety technology	13	Transfer modules for tool coding	55
Millions of docking cycles – with minimum wear	14	Ground pin modules for shielding and earth connection	56
IDA bus module	15	Primary circuit modules for welding power transmission	57
Stäubli's global competence and local presence	16	Integrated bus module IDA for condition monitoring	58
100 % Stäubli performance	17	Electrical modules for signal and servo power transmission	62
From robot performance data to system selection	18	Active Docking safety modules	70
		CUSTOMIZED modules for special requirements	72
<b>Payload overview</b>	<b>19</b>		
		<b>MPS CUSTOMIZED</b>	<b>76</b>
		<b>Wiring diagrams</b>	<b>78</b>
		<b>Pneumatic diagrams</b>	<b>85</b>

**R** **Base unit  
robot side**

 **Process safety**  
Maximum process safety for  
equipment and personnel

 **Economic efficiency**  
for cost-effective and sustainable  
production processes

**T** **Base unit  
tool side**

 **Flexibility**  
for maximum function diversity in  
robotic manufacturing processes

 **Productivity**  
for innovative and quality-  
optimised production processes

**THREE SOLUTIONS**

# Our systems are just as flexible as your processes

Stäubli robotic tool changing systems are designed according to a modular product concept that guarantees variable multi-functionality and optimum integration into all industrial robot manufacturing processes.

Payload-specific base units on the robot and tool side are the basis for the three Stäubli tool changing system solutions.

## MPS COMPLETE

Ready-to-use application solutions

- robot tool changer modules suitable for the most common manufacturing processes worldwide
- shortest delivery times for complete systems
- can be supplemented with further transfer modules at any time
- simple and easy connection of the robot cable package
- future repositioning of the transfer modules to adapt to requirements

## MPS MODULAR

Individually configurable solutions

- full choice of transfer modules
- delivered as a fully assembled robotic tool changer
- simple configuration system for the entire ordering process
- shortest delivery times for single components
- flexible positioning of the transfer modules for easy connection of the cable package
- future repositioning of the transfer modules to adapt to requirements

## MPS CUSTOMIZED

Customized designs

- individual design of all performance data, material qualities and connection options
- all individual components are adapted to the specific application
- individual tool stands enable optimal system integration
- flexible positioning of the transfer modules for easy connection of the cable package
- future repositioning of the transfer modules to adapt to requirements

## SYSTEM STRUCTURE

# A flexible concept for every robot

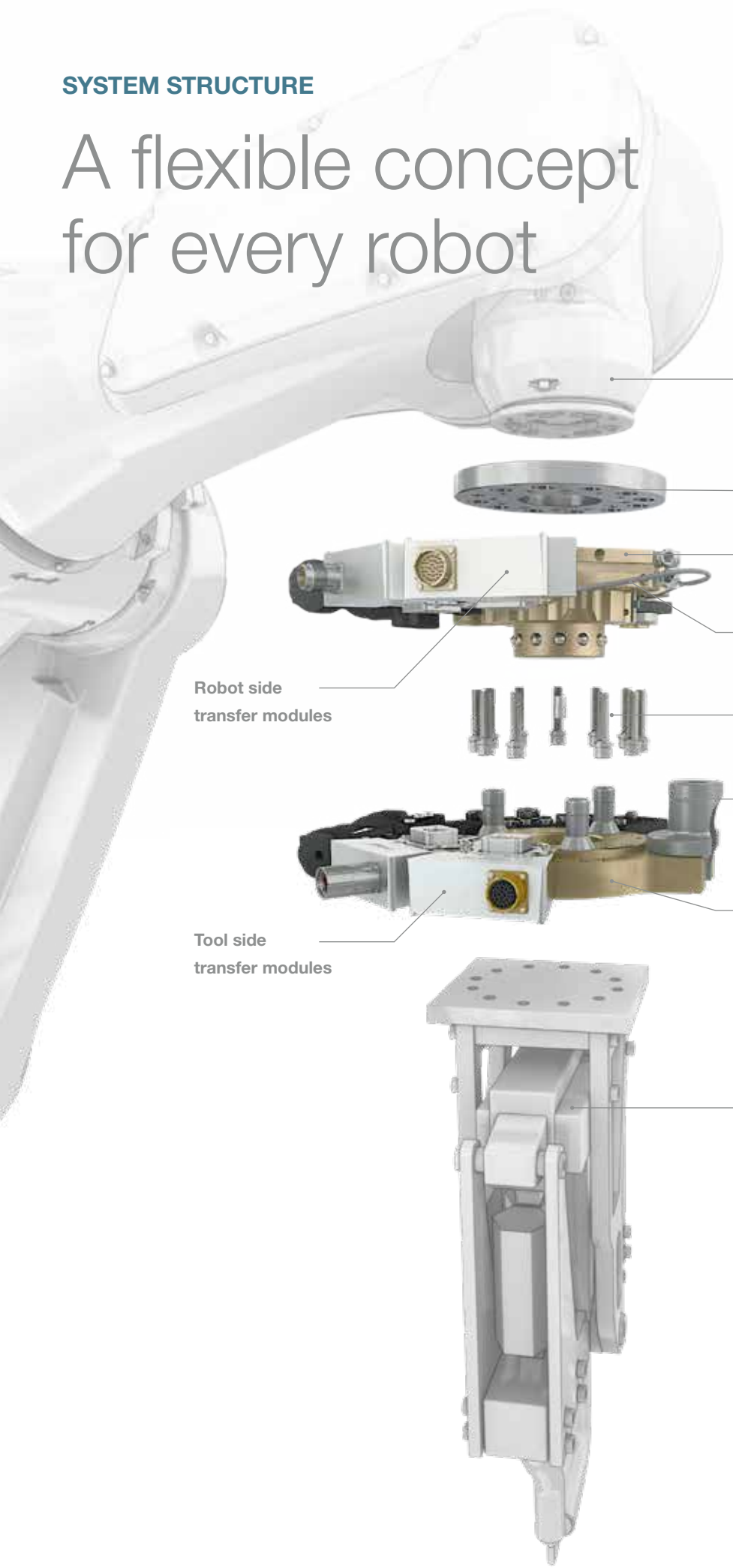

**Robot**  
Mounting on the flange suitable for all makes of robot

**Robot adapter flange\***

**R** Base unit robot side

Sensors

Robot side transfer modules

Mounting kit robot side



Tool side docking hook

Tool side transfer modules

**T** Base unit tool side

**Tool**  
Signal, media and power supply of the tool through transmission modules

\* Including mounting materials.

TOOL STAND TECHNOLOGY

# Optimal system integration for maximum efficiency

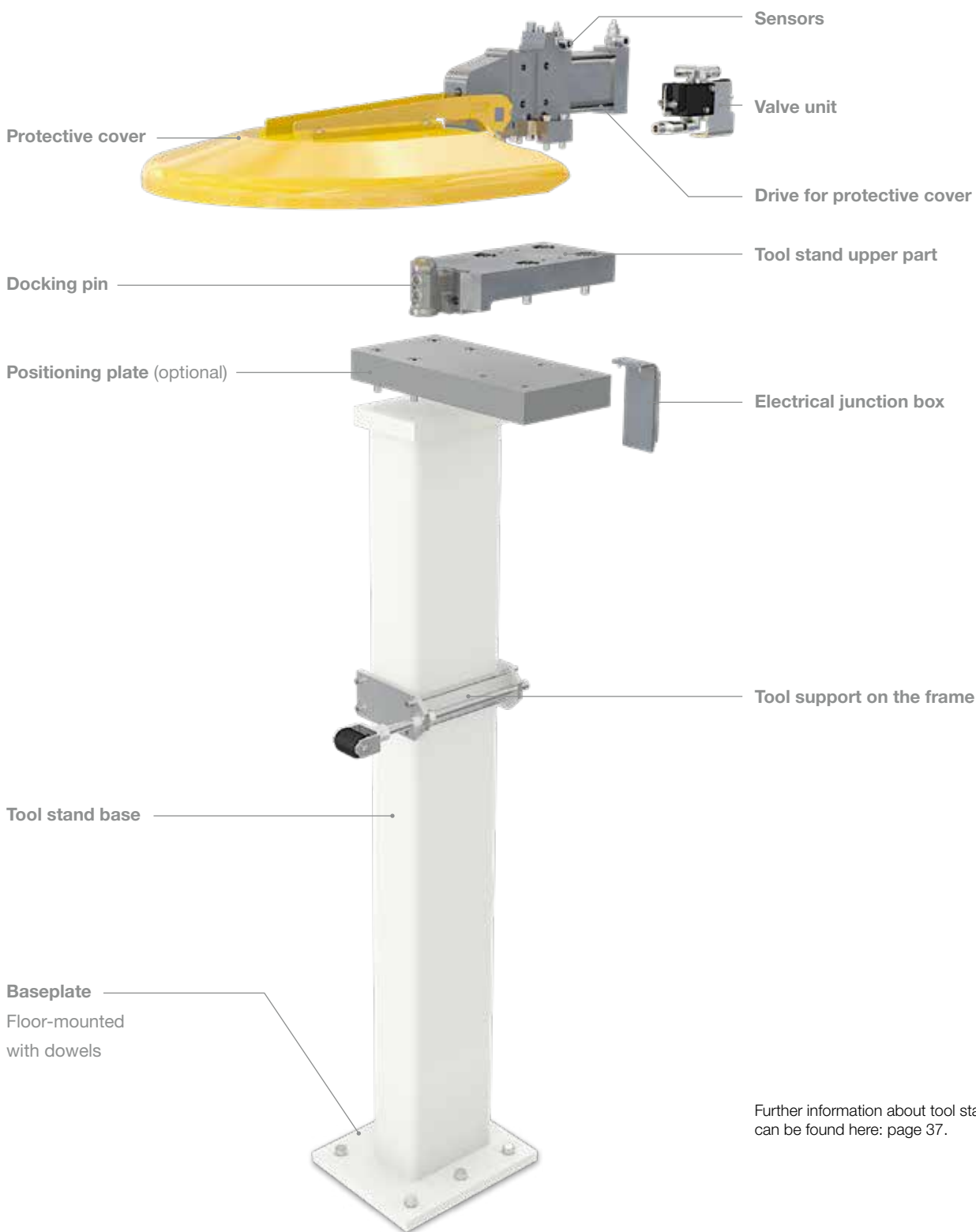

Further information about tool stand technology can be found here: [page 37](#).

## QUICK CHANGE TECHNOLOGY

# Tool changing system – robot and tool side

**R** Base unit  
robot side

Pressure switch  
for monitoring

Active Docking  
safety module

SPM transfer module  
for fluids and pneumatics

Sensors for status  
indication

RMK transfer modules  
for pneumatics and vacuum

Transfer modules SPC  
for Hydraulic

MultiDNet-R electrical module  
for signal and servo power  
transmission

Module for tool coding

WPC4 primary circuit module  
for welding power transmission

**T** Base unit  
tool side

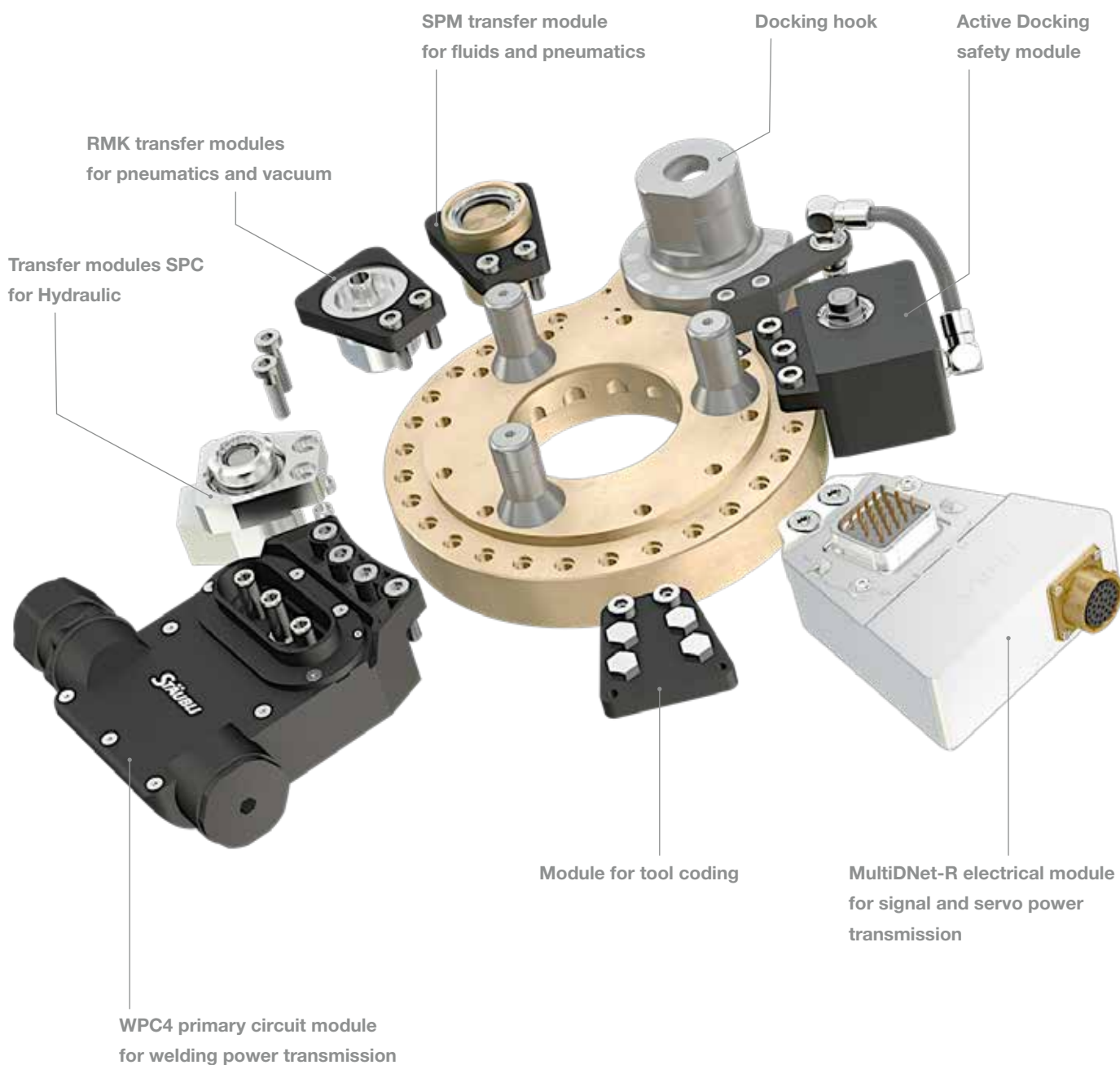

# Multi-functionality – for diverse technology

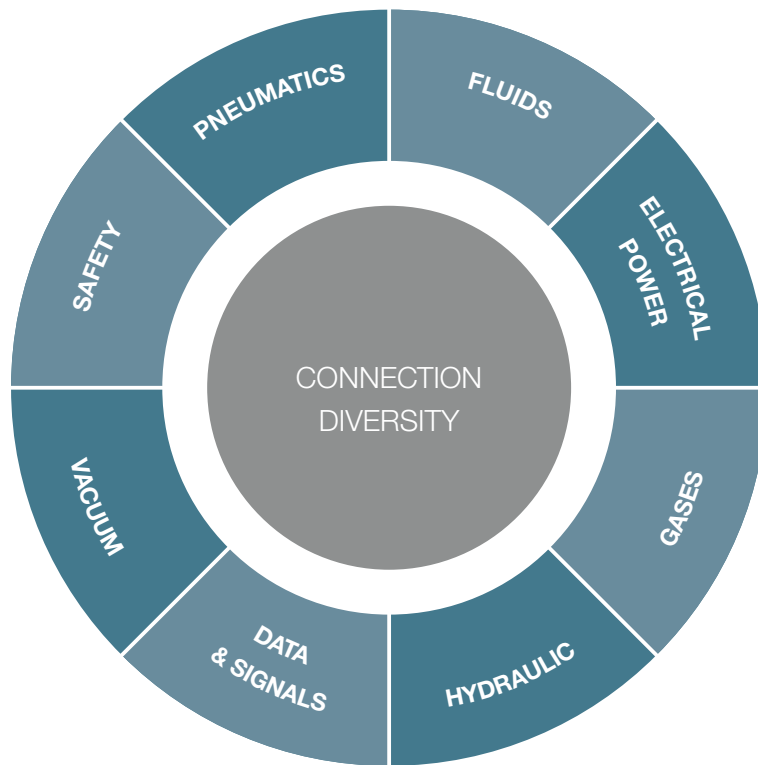

**Stäubli MPS systems can be equipped with a wide range of transfer modules for different applications. This multi-functional design maximises production efficiency covering the entire spectrum of industrial robot applications. Stäubli MPS systems incorporate more than 60 years of expertise in coupling technology for electrical and fluid media exploiting the full potential of robotic production technology.**

The basic units on the robot and tool side are circular in design maximising flexibility when equipping the tool changer system with a variety of transfer modules.



#### **Flexibility**

Robot versatility is guaranteed because of the diverse modules. Energy and data transfer can be added to the robotic tool changing systems at any time. As a pioneer in coupling technology with decades of experience, Stäubli can also design individual coupling and connection solutions for specific requirements.



#### **Productivity**

Stäubli robotic tool changers provide flexible technology and productivity in a wide range of applications: from simple handling applications to various welding methods, punch riveting, screwing, gluing and material transfer.



# Modularity orientated to requirements

The MPS systems are based on a modular concept that provides the ideal platform for a flexible and versatile system. For all robotic applications there are suitable transfer modules available – developed by Stäubli and easily integrated into the changers.

On the robot side, the tool changers are already equipped with the maximum configuration of transfer modules for the robot's applications. The tool side is only equipped with the transfer modules that are required for the respective tool.



## Flexibility

The modular design makes it possible to adapt the system at any time. This allows you to make unlimited changes to your robot manufacturing processes. The robotic tool changer's function can be adapted to changing requirements and new technologies.



## Economic efficiency

The MPS tool side base unit is only populated with the transfer modules that are necessary for the respective tool, reducing the investment to a minimum.

## Gripping/ welding



## Gripping

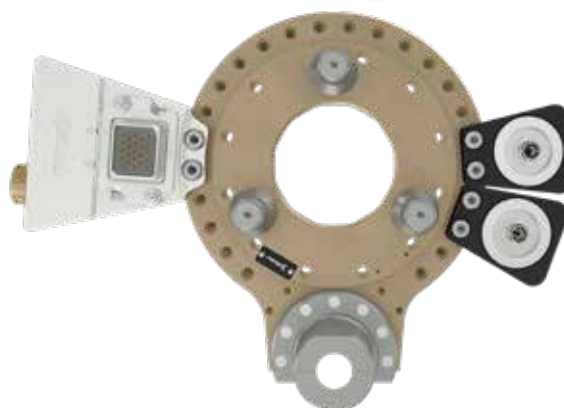

## Welding



# Powerful base unit – high precision locking

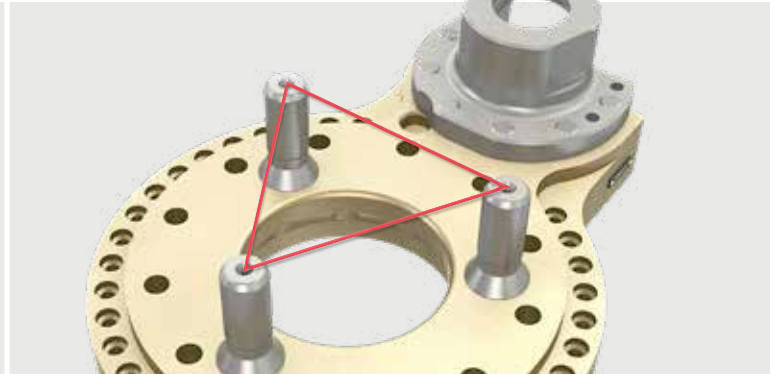
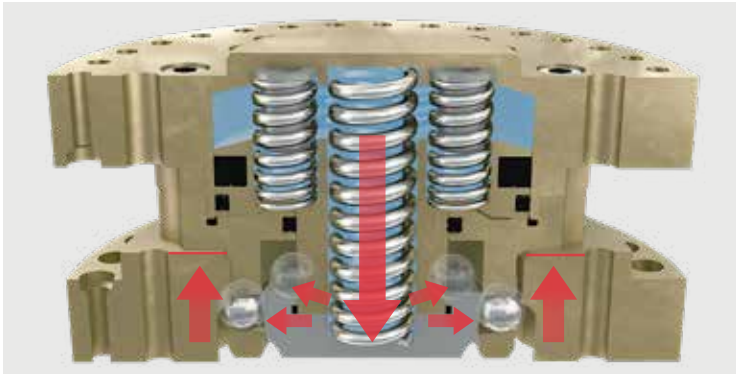

**Powerful and precise locking for  
safe and error-free processes**

**Stäubli tool changing systems ensure high-precision connection between the robot and the tool. The intelligent design of the robotic tool changer ensures absolute precision and a long service life.**

The robot and tool side are pre-aligned and brought together via three guide columns. The conical locking surfaces ensure exact positioning between the two sides of the MPS tool changing system. A large volume of high-strength locking balls maintain the friction lock between robot and tool.



## **Process safety**

You benefit from the precise repeatability of the changer system ( $\pm 0,01$  mm for each axis). Even following a high number of change cycles, the tools are brought to their exact operating position, and placed precisely on the tool stand. Designed for horizontal or vertical use, the tool stand, with optional tool support, is an integral part of the system.



## **Economic efficiency**

Due to the high-precision locking even extremely bulky tools can be precisely positioned as defined by the manufacturing process, guaranteeing consistent product quality.



## **Productivity**

The lock is designed for an extremely high number of change cycles. This guarantees permanent precision and maximises production output.

# Smart details – for perfect connections

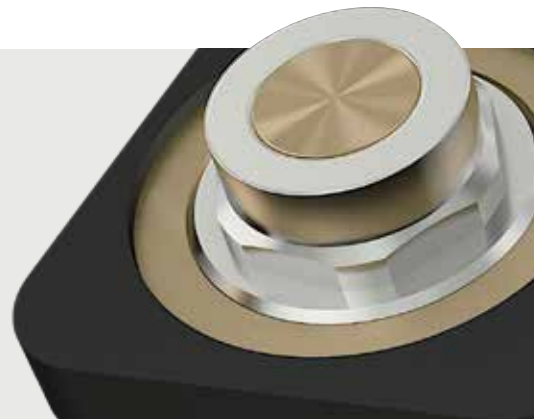

**Coupling technology that guarantees maximum power transmission**

**As the global market leader in high-quality coupling technology, Stäubli has been developing and designing connection solutions for media, data and energy transmission for decades. In industrial applications these solutions have proven to be reliable over time with low levels of wear and tear, even when operated under tough conditions.**

Stäubli designs durable and robust transfer modules for robotic tool changing systems reaching the highest quality levels. As a result of their highly efficient and intelligent design concepts, both the media couplings and the electrical plug connections guarantee 100% power transmission. MULTILAM technology minimises contact resistance and maximises contact integrity in electrical signal transmission – even with high current.



#### **Process safety**

Constant and maximum media and energy transfer is guaranteed for the long term.



#### **Economic efficiency**

The Stäubli transfer modules are designed for an extremely high number of mating cycles and therefore have a very long service life.

# One system for all robots

**Stäubli's competence in all aspects of robotic tool changing systems draws on its decades of experience as a robot and coupling manufacturer. Based on its in-depth technical know-how of the industrial requirements of robotic production lines, it has developed versatile tool changer solutions that are suitable for robots supplied from any manufacturer.**

The MPS systems developed by Stäubli can be installed on any robotic arm anywhere in the world, whatever its type, make or year of production. The changer mounting flanges are based on ISO-standard drilling patterns, but can easily be adapted to other robot flange patterns. The height of the tool changing system in the coupled state is restricted to the minimum so that its full load bearing capacity can be exploited.

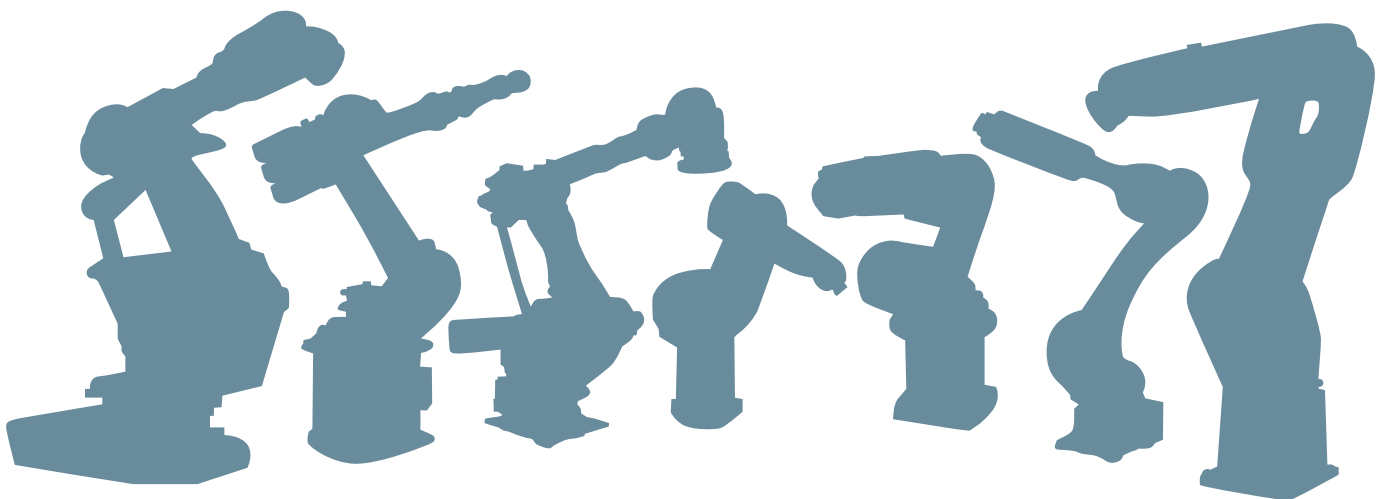

# Certified safety technology for people and facilities

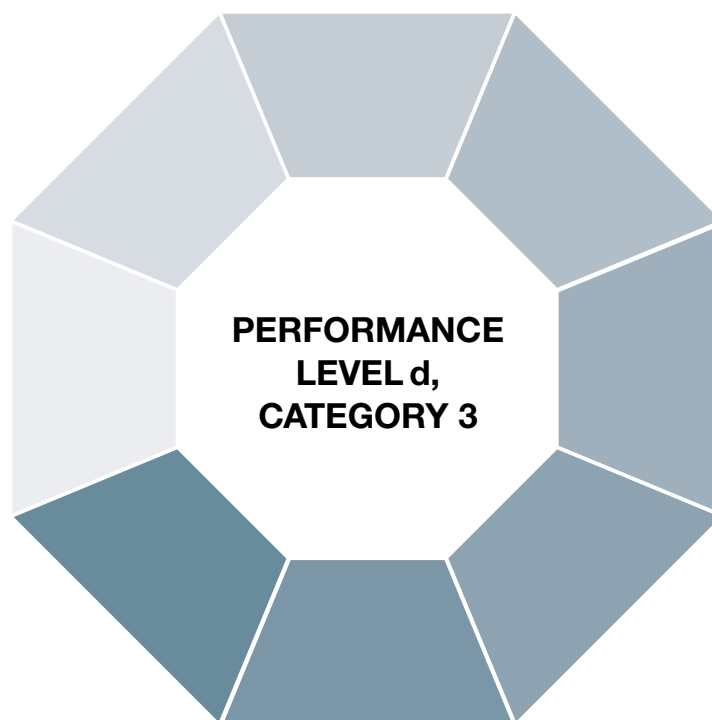

**Personnel and plant safety is essential in automated processes. Manufacturers and operators of robots and robotic devices have to ensure compliance with the ISO 10218-2 standard. Stäubli robotic tool changers satisfy the demanding requirements of “Performance Level d, Category 3”. The safety concept for the Stäubli MPS systems provides reliable protection for operators and safeguards process quality.**

This MPS system safety level can either be achieved by electromechanical transponder technology or with the Active Docking System developed by Stäubli. Both are integral aspects of the product concept.

The **transponder option** consists of a safety switch in combination with the Stäubli ISB 200 logic module acting as a bus system-independent safety circuit.

The **Active Docking System** is a proprietary development by Stäubli. The compressed air supply for the decoupling process is provided as an individual circuit that is only available in the tool stand. This means that the tool can only be unlocked at the tool stand. Once the robot has picked up a tool it cannot be accidentally unlocked because there is no connection to the compressed air supply.



#### **Process safety**

Maximum safety of robot systems, operators and automated tool change processes are guaranteed.

# Millions of docking cycles – with minimum wear

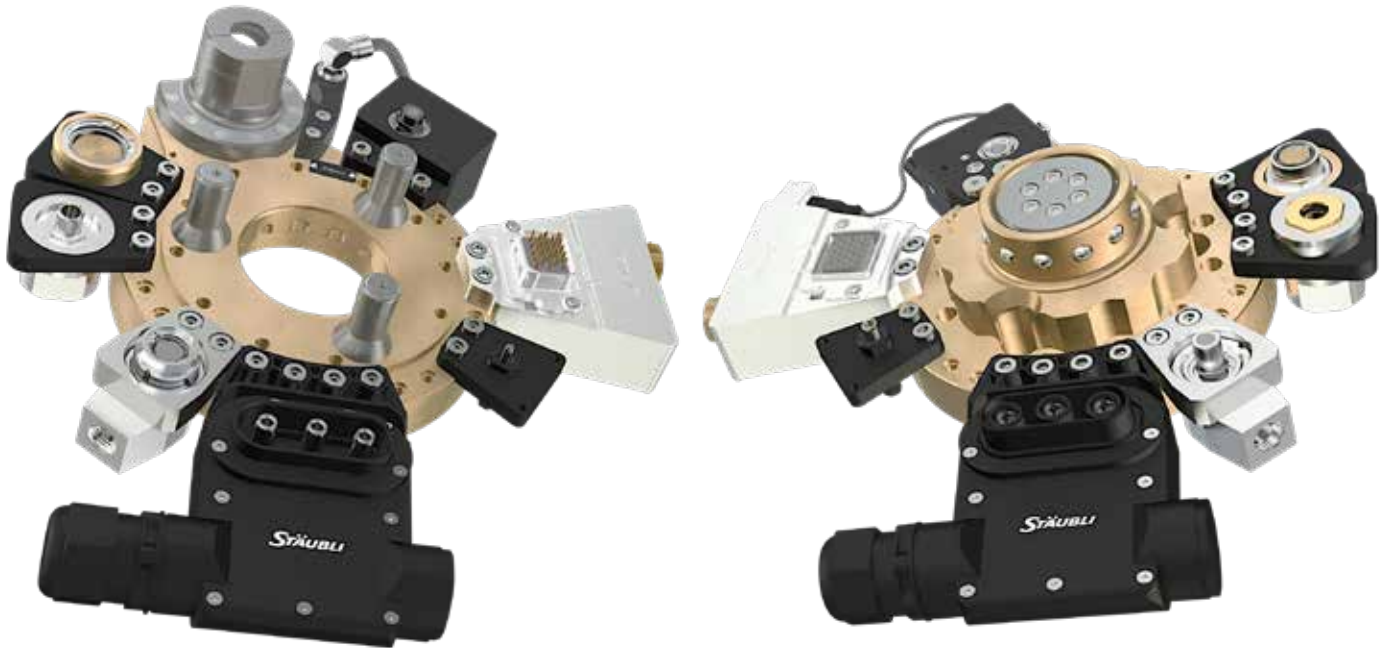

All the media couplings and electrical connectors integrated in the modules feature floating contact technology. This reduces wear to a minimum, ensuring a precise and reliable connection even after millions of docking cycles. For maintenance purposes, parts can be replaced quickly with minimal interruption to the robot workflow.

Transfer modules and connectors can be replaced directly on the MPS system without the need to disassemble the tool changer, or to disconnect cables and hoses. This allows entire modules to be replaced quickly and easily. A cartridge system (Quick Change Inserts) makes it possible to replace worn parts directly in the modules.



#### Process safety

Floating contact technology allows the plug and socket for fluid connectors and the pins and socket for electrical connectors to align. This ensures perfect connection of both fluid and electrical connections.



#### Economic efficiency

The long life of Stäubli components guarantees a reliable coupling processes even after millions of docking cycles. Long maintenance intervals reduce downtime, as well as repair and replacement part costs.



#### Productivity

The service-friendly design of the transfer modules, as well as the integrated media couplings and electrical connectors, ensure maintenance time is minimal.

# Simple integration – the IDA bus module



**Control, monitor, report: the newly developed, integrated IDA bus module is able to communicate with all sensor interface functions during the tool changing process, as well as the actuators located in the robot's working range. The compact module processes all signal and control current transmissions, connecting the entire tool change monitoring process, the necessary status queries and tool coding via the bus system in the robot controller. The system communicates with the higher-level control unit via the standard ProfiNet, Ethernet IP and Modbus protocols.**

The integrated IDA bus module connects all the safety-relevant monitoring and diagnostic functions. This module also provides shielding, earthing and an automatic power shut off for the actuators during the coupling process.



### Productivity

The IDA bus module, which functions as a central interface, can be quickly and easily installed on the base unit. It requires one module slot on the changing system base unit and links all the sensors via a central plug connection. Only the bus cable, power supply and the operational grounding are connected to the robot. Our easy-to-use web application is available for software configuration.



### Process safety

With its extremely small mounting radius, the integrated IDA bus module has a minimal interference profile. Combining the interface functions into a single component reduces the number of cable connections to the minimum. As a result, the entire tool changer system is significantly smaller, which minimises the risk of collision and allows the robot's hand to move in places that would otherwise be difficult to access. The robust IDA housing is constructed from metal, which ensures that the heat generated by the electronic components is optimally conducted away from the module. This tool changing system is designed to withstand harsh ambient conditions, of up to IP65.

# Stäubli's global competence and local presence



**Stäubli has subsidiaries at major industrial hubs around the world. Their experienced engineers have detailed, product-specific know-how and application expertise to provide the highest quality of advice to customers and to guarantee fast response times worldwide.**

Robotic tool changers are variable systems that have to be efficiently integrated into production processes, therefore advice to customers on the correct basic and special configurations, adaptations and optimisations is essential. Our global warehousing concept ensures that components and spare parts are quickly delivered to customers around the world.



## **Flexibility**

Users receive solutions that comply with all country-specific guidelines and standards. The robotic tool changing systems are adapted to national industrial norms, such as thread standards or information retrieval technologies in sensor systems. Thanks to our global network customers can easily implement multi-national production concepts.



## **Productivity**

Wherever in the world, users receive specialist advice on applications. This guarantees the best possible implementation of the tool changing processes on robot lines at any production site. Customers have access to our global

know-how so that you can maximise the productivity of new plants and achieve optimum results in retrofit and maintenance situations.



## **Economic efficiency**

Single point of contact: we designate one customer consultant to you for the entire duration of your project. This makes the cooperation more efficient and reduces the complexity of project coordination and implementation. Customers also benefit from our consulting expertise directly at your premises when you implement tool changing systems.



# 100 percent Stäubli performance

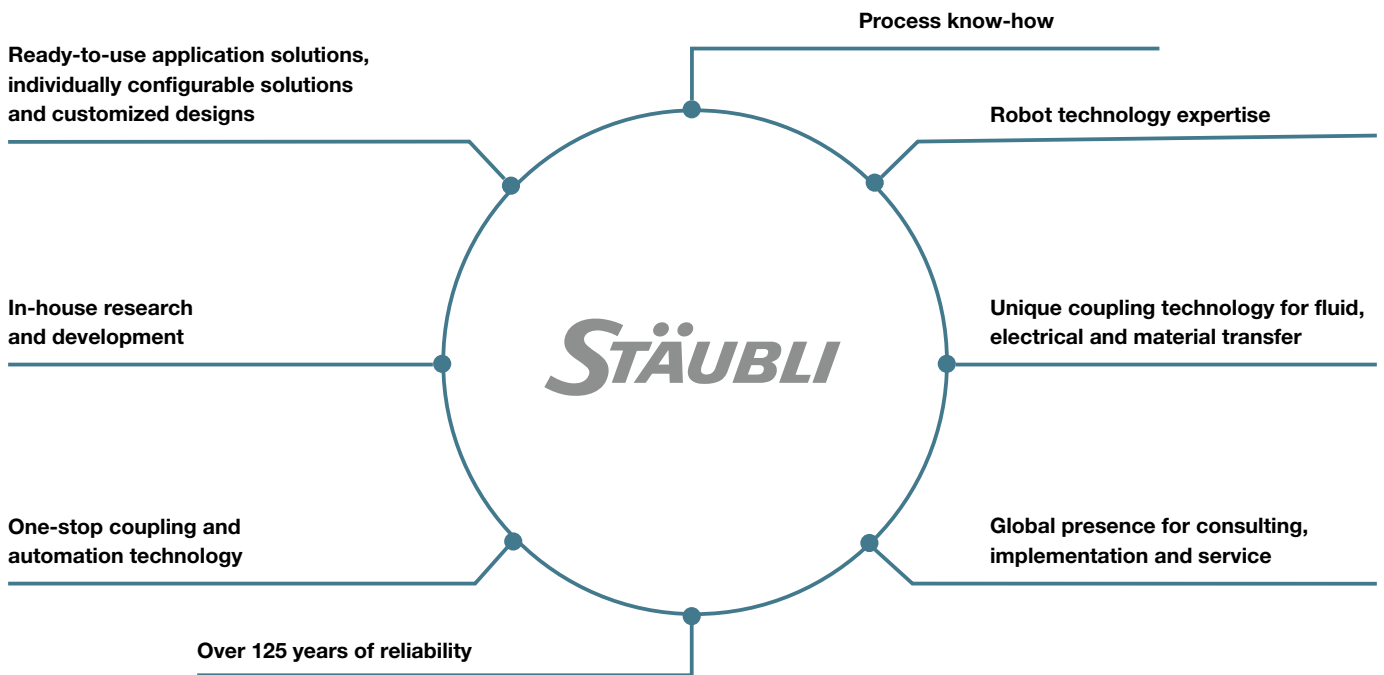

**All the components of the Stäubli MPS systems come from a single source and are perfectly harmonised. Stäubli performance is 100% based on a combination of products, expertise and know-how.**

All individual components – from base unit to transfer module – are developed and manufactured by Stäubli. As your single contact we are responsible for the entire MPS system. Our customers can count on us supporting them with our expertise and experience.



### Process safety

You have the assurance of integrating well-engineered and comprehensively tested robotic tool changers into your production line. All systems and components are designed and manufactured by Stäubli to the highest industrial standards, supporting you with our process analysis and optimisation know-how.



### Flexibility

Stäubli's robotic tool changing systems are designed for application-specific module and component configuration. The product concept makes complete ready-to-use systems (MPS - COMPLETE), individually configurable systems (MPS - MODULAR) and customized designs (MPS-CUSTOMIZED) possible.



### Economic efficiency

With over 60 years of experience as a global manufacturer in coupling technology for media and power connections, Stäubli delivers unprecedented performance and longevity. Component compatibility is guaranteed – ensuring risk free investment.

# From robot performance data to system selection

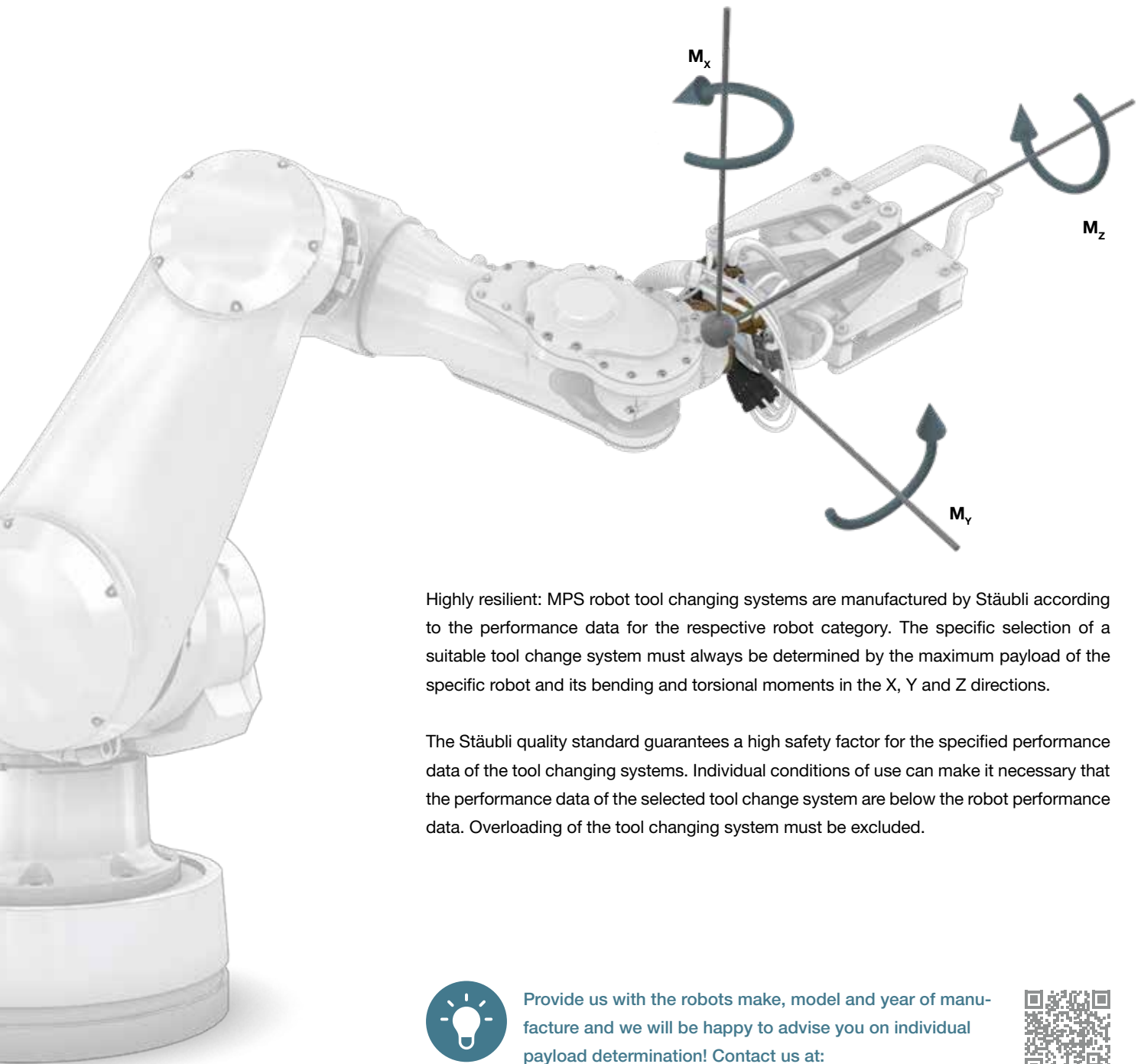

Highly resilient: MPS robot tool changing systems are manufactured by Stäubli according to the performance data for the respective robot category. The specific selection of a suitable tool change system must always be determined by the maximum payload of the specific robot and its bending and torsional moments in the X, Y and Z directions.

The Stäubli quality standard guarantees a high safety factor for the specified performance data of the tool changing systems. Individual conditions of use can make it necessary that the performance data of the selected tool change system are below the robot performance data. Overloading of the tool changing system must be excluded.



Provide us with the robots make, model and year of manufacture and we will be happy to advise you on individual payload determination! Contact us at:



[www.staubli.com](http://www.staubli.com)

PAYLOAD OVERVIEW



	MPS 631		MPS 631S	
	$M_x / M_y$	$M_z$	$M_x / M_y$	$M_z$
max. static moment*	3200 Nm	3200 Nm	5000 Nm	5000 Nm
max. dynamic moment*	11200 Nm	11200 Nm	17500 Nm	17500 Nm
max. payload	630 kg			
max. repulsion force	36 kN			
max. connection force	72 kN			
max. lateral force	36 kN			
max. permissible acceleration	50 m/s <sup>2</sup>			
Pitch circle diameter (PCD) robot adapter flange	ISO 9409-1-160-11-M10 ISO 9409-1-160-11-M12			
Height (coupled)	100 mm			
Weight - robot side	6.5 kg			
Weight - tool side (included adapter)	4.9 kg		5.4 kg	
Compressed air connection	Push-lock hose-Ø 8 mm			
Pneumatic ball locking	0.45 - 1.2 MPa 2.3 NI/cycle at 0.6 MPa			
Repeatability	+/- 0.01 mm			
Query	locked/unlocked/coupled			
Emergency release	yes			
Safety in case of drive medium failure	yes, by compression spring			

\* Due to their potentially high acceleration, robots can generate dynamic moments that are several times higher than static moments. The dynamic moments can occur in an emergency stop situation of the robot. Since they occur only very rarely during the robot's lifetime a static proof of strength is usually sufficient for this purpose.



Check out our comprehensive MPS range. Contact us for other payloads and special designs.



[www.staubli.com](http://www.staubli.com)

MPS 631 COMPLETE

# MPS 631/1 IDA SAFETY

For handling and gripping applications  
With IDA and Active Docking

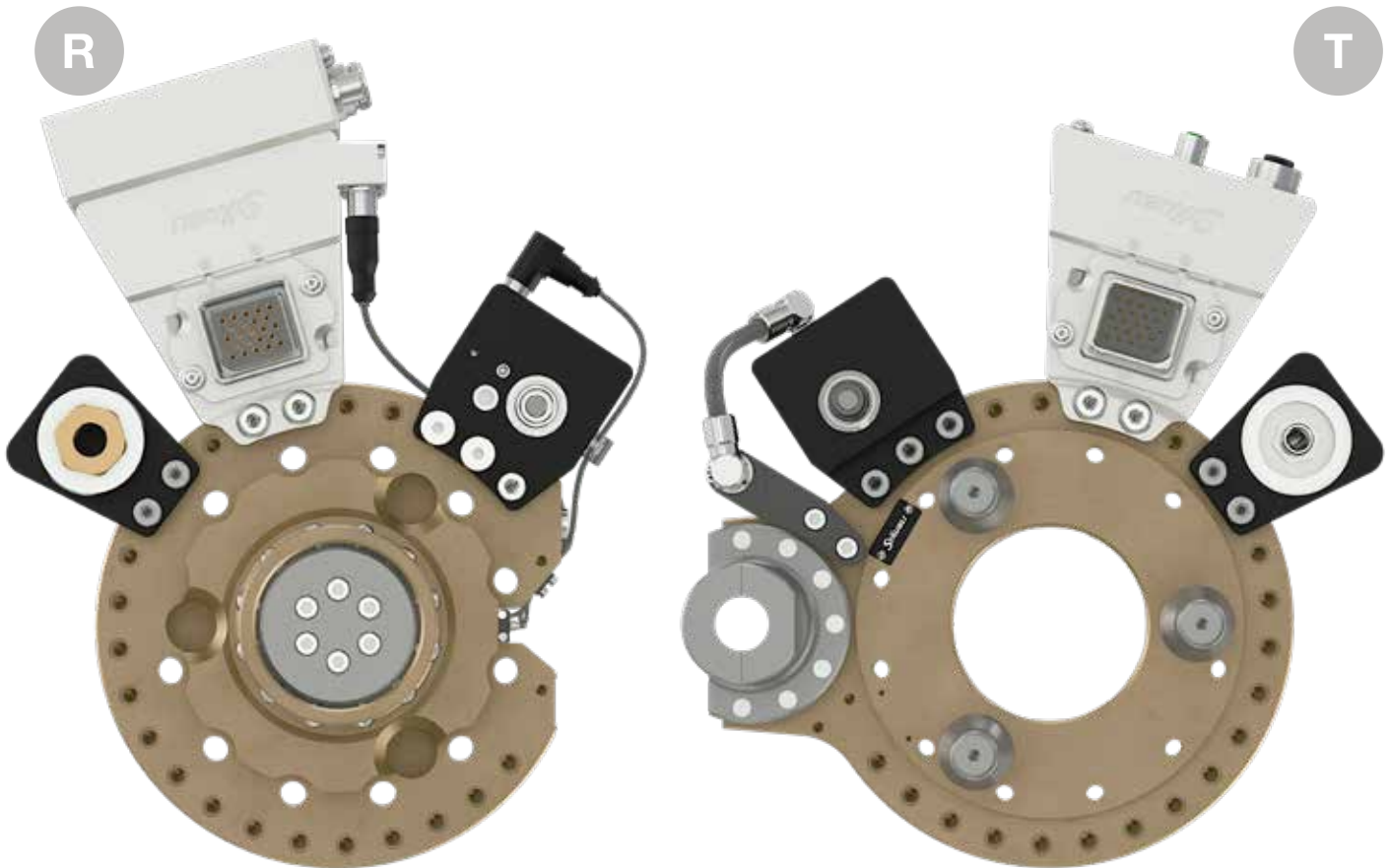

Application	Sensors	Connection transfer modules*		Order no.
		Pneumatic	Integrated bus module	
Gripping/handling	R PNP	1x G 3/8	M12-D coded 7/8 5-pole	MPS631RD-0000-0000-0000-00WM-IDAA
Gripping/handling	T -			MPS631TC-0000-0000-0000-00WM-IDAA

Technical data for the base unit on the robot and tool sides can be found on page 28.  
\* Technical data for all transfer modules can be found from page 48 onwards.



Transfer modules with alternative thread and plug connections can be customized using our simple configuration system (see page 26).

R

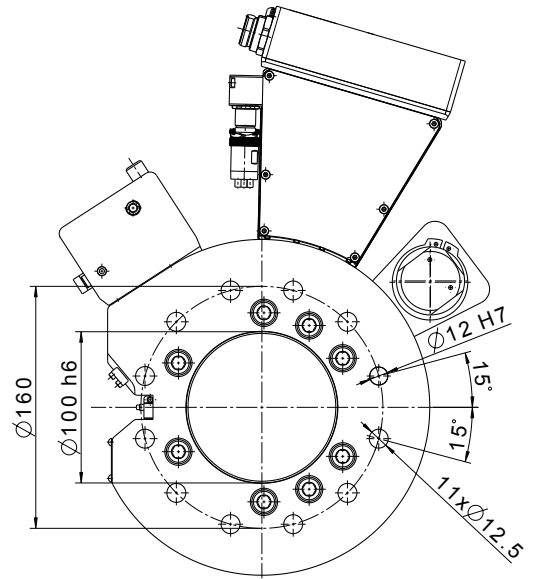
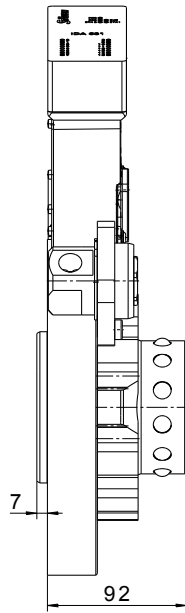
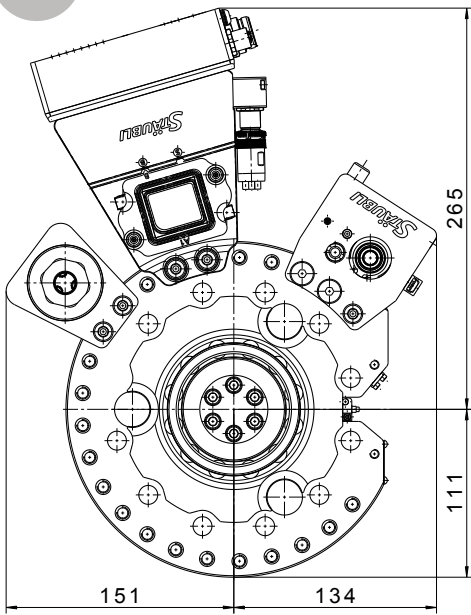

T

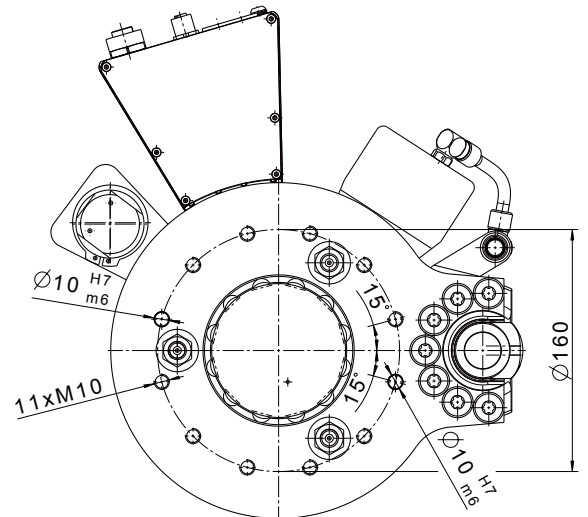
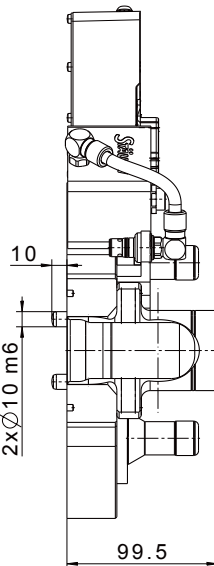
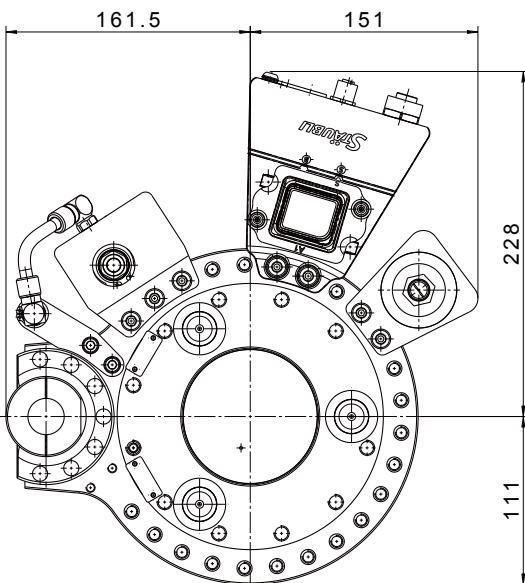

MPS 631 COMPLETE

# MPS 631/2

For handling and gripping applications

R

T



Application	Sensors	Connection transfer modules*		Order no.
		Pneumatic	Signal	
Gripping/handling	R PNP	1x G 3/8	KPT2E18-32P	MPS631RC-0000-0000-0000-00WM-ECBB
Gripping/handling	R NPN			MPS631RG-0000-0000-0000-00WM-ECBB
Gripping/handling	T -		KPT2E18-32S	MPS631TA-0000-0000-0000-00WM-ECBB

Technical data for the base unit on the robot and tool sides can be found on page 28.  
 \* Technical data for all transfer modules can be found from page 48 onwards.

 Transfer modules with alternative thread and plug connections can be customized using our simple **configuration system** (see page 26).

R

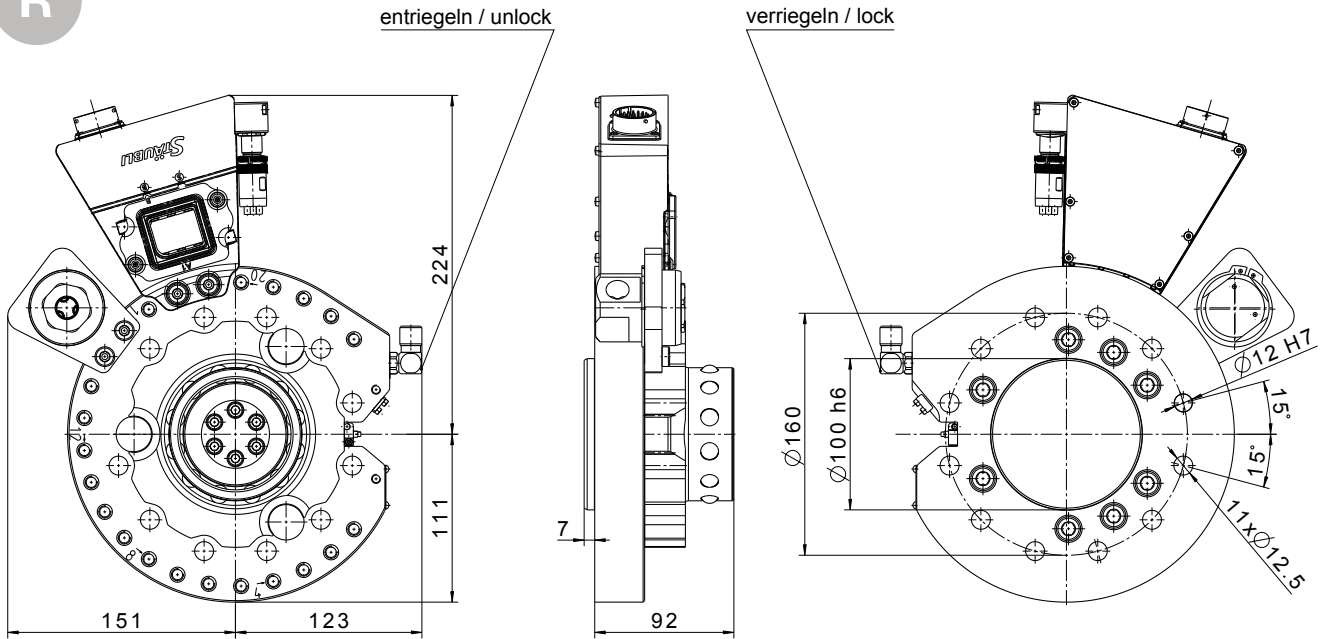

T

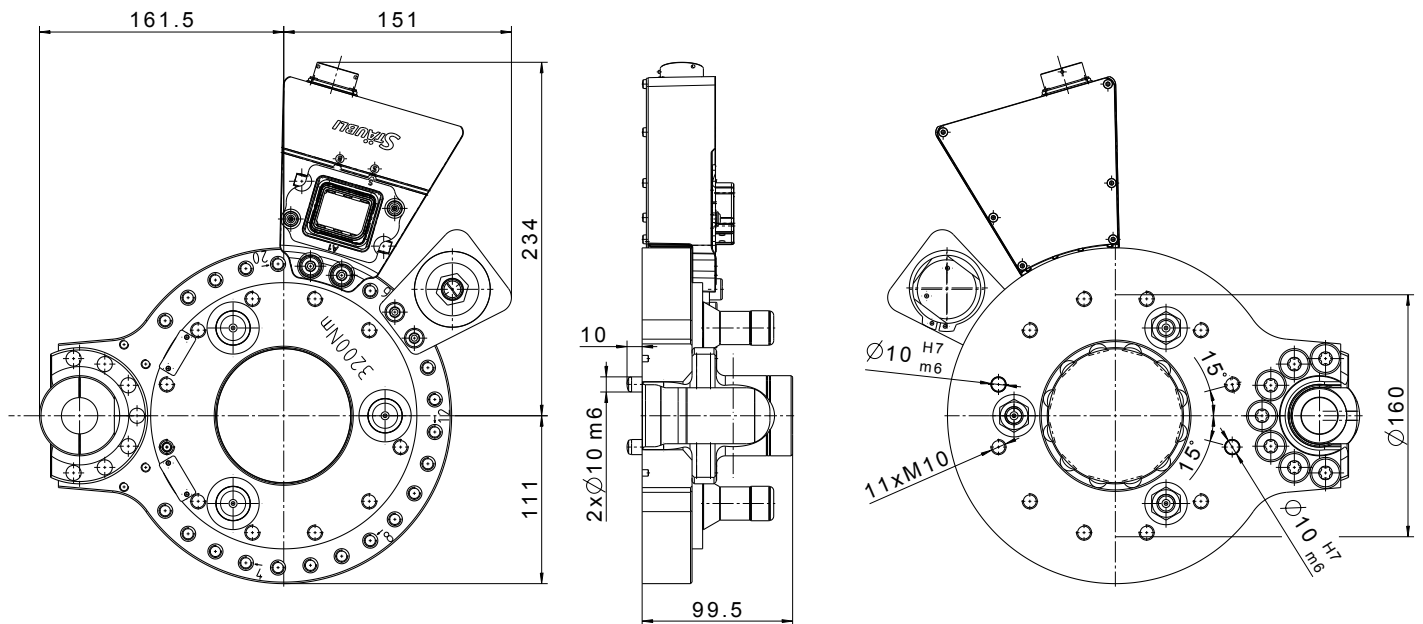

## MPS 631 COMPLETE

# MPS 631/3

For handling, gripping and welding applications



Application		Sensors	Connection transfer modules*				Primary circuit
			Pneumatic	Signal	Fluids	Servo	
Welding/gripping	R	PNP	2x G 3/8	KPT2E18-32P	2x G 1/2	B EG A 120 MR 11 00 0200 400	1x M40
Welding/gripping	R	NPN				B DF A 108 FR 05 00 0150 000	1x M40
Welding	T	-		KPT2E18-32S	-	-	1x M40
Gripping	T	-			-	-	-

Technical data for the base unit on the robot and tool sides can be found on page 28.

\* Technical data for all transfer modules can be found from page 48 onwards.

Application		Sensors	Order no.
Welding/gripping	R	PNP	MPS631RC-WTWT-WMWM-WPBA-ECBC-ECBB
Welding/gripping	R	NPN	MPS631RG-WTWT-WMWM-WPBA-ECBC-ECBB
Welding	T	-	MPS631TA-WTWT-WMWM-WPBA-ECBC-ECBB
Gripping	T	-	MPS631TA-0000-WMWM-0000-0000-ECBB



Transfer modules with alternative thread and plug connections can be customized using our simple [configuration system](#) (see page 26).



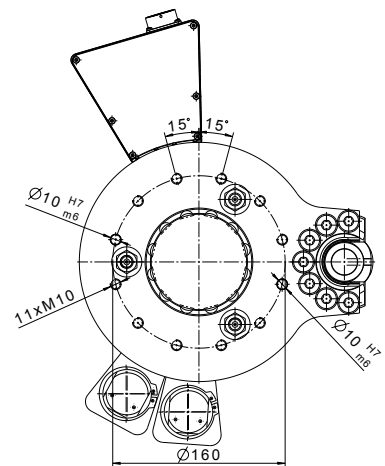
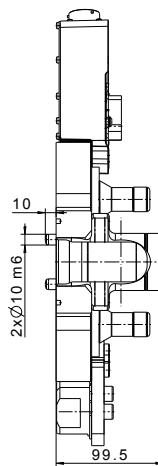
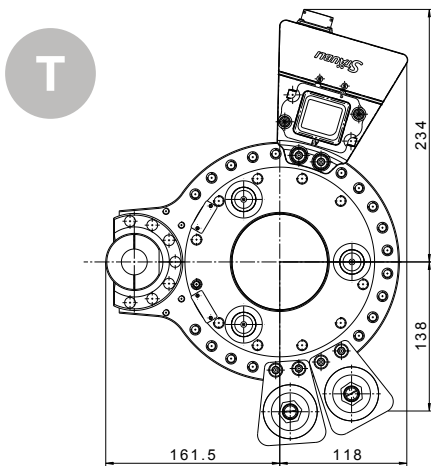
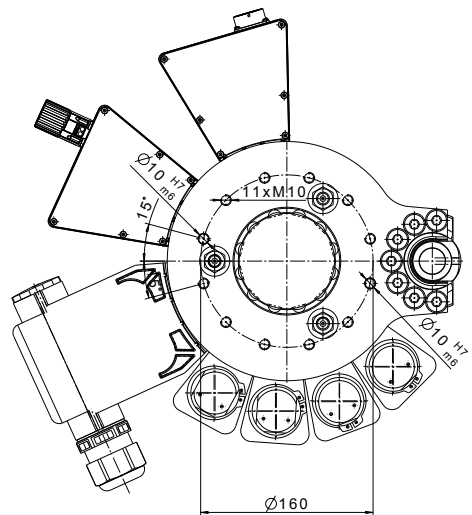
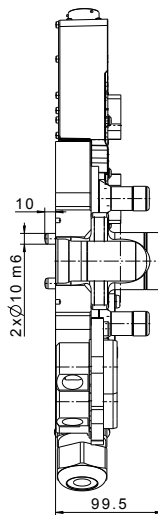
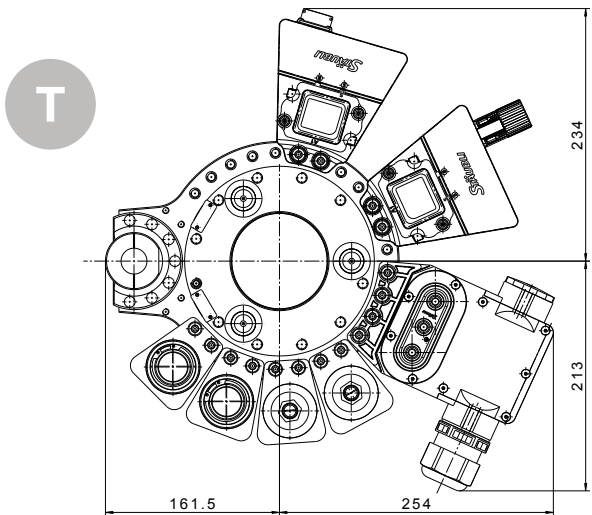
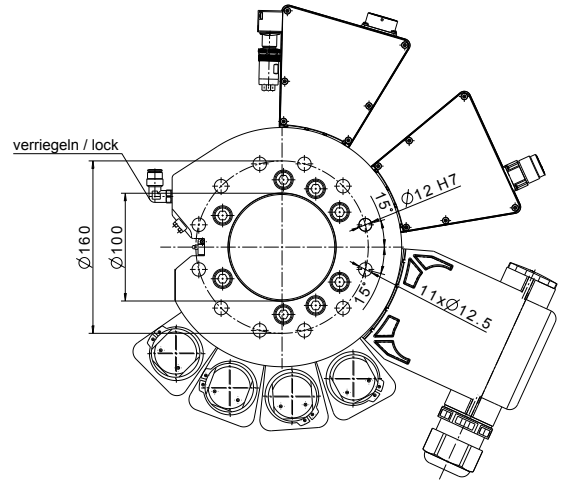
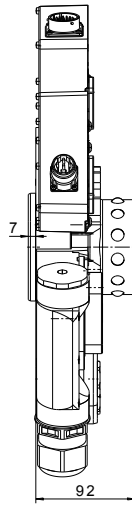
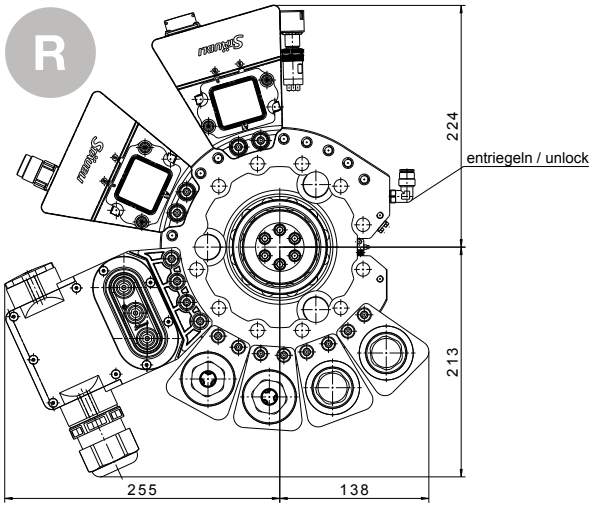

## MPS 631 MODULAR

# Just a few steps to your modular solution

Take advantage of Staubli's modular product concept for maximum design freedom.  
Configure your perfect tool changing system in just 4 easy steps.



R

**1** Choose your **base unit** (page 28) and note the module order code.

**2** Choose your **transfer modules** (from page 48 onwards). Position the modules on the mounting holes 1 to 20 by entering the module order code. IDAA, ECBI and ECBB must be mounted in hole positions 17 to 20.

M P S 6 3 1 R D - 1 2 3 4 5 6 7 8 9 10 11 12 13 14 15 16 17 18 19 20  
W T W M - O O W W - W P B A - O O M R - E C B B

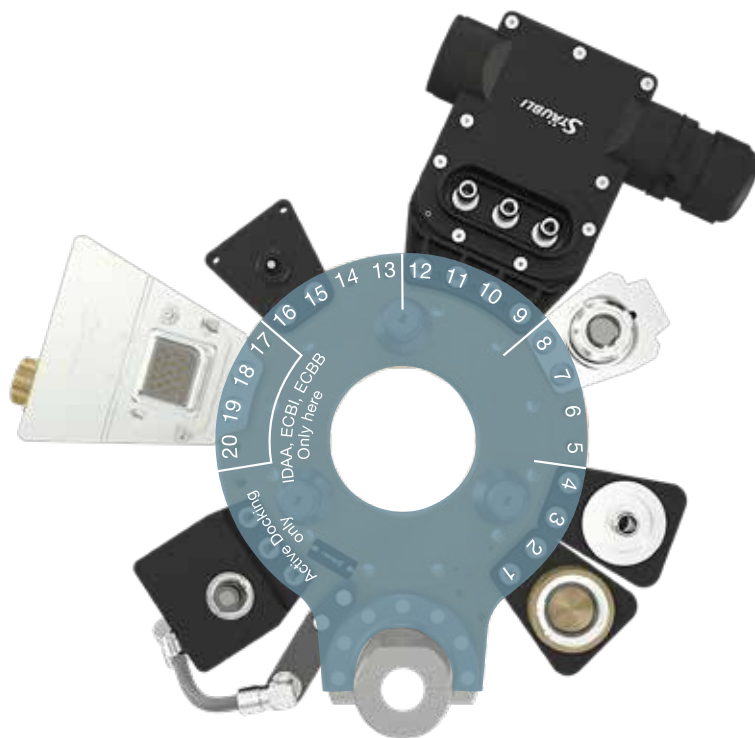

T

**3** Select the appropriate **base unit** for your tool side (from page 30).  
Transfer the module order codes of the **transfer modules** corresponding to the robot side.

M P S 6 3 1 T C - W T W M - 0 0 W W - W P B A - 0 0 M R - E C B B  
 1 2 3 4 5 6 7 8 9 10 11 12 13 14 15 16 17 18 19 20

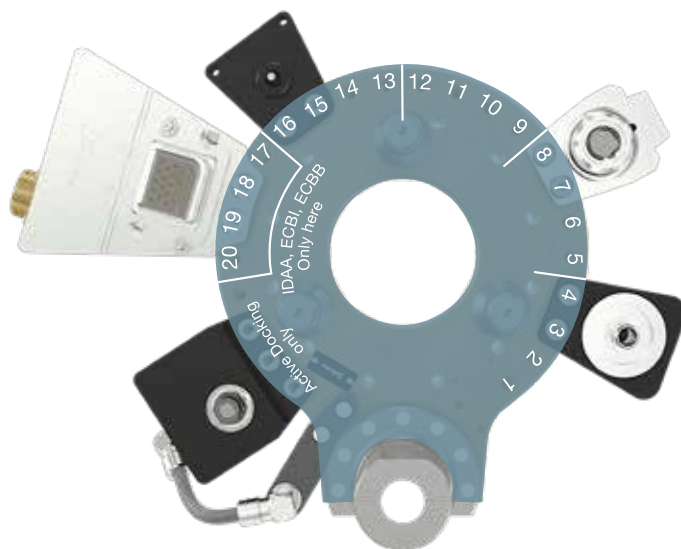

T

**4** **Reduce your investment** by varying your tool side and removing any transfer modules that aren't needed (Replace module order code with 00 or 0000).

M P S 6 3 1 T C - 0 0 W M - 0 0 W W - 0 0 0 0 - 0 0 M R - E C B B  
 1 2 3 4 5 6 7 8 9 10 11 12 13 14 15 16 17 18 19 20

## MPS 631 MODULAR

# MPS 631 base unit robot side

### MPS 631RA/RE

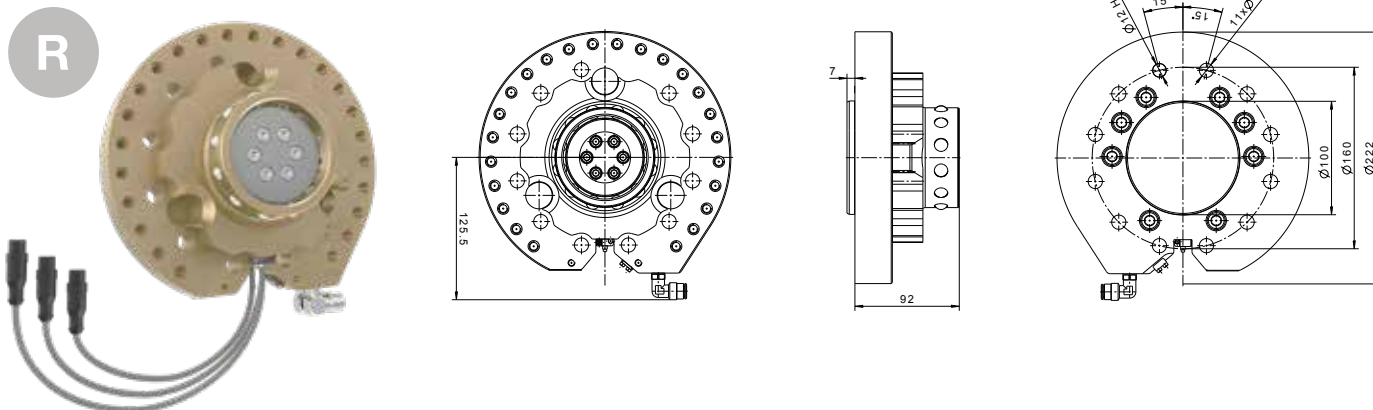

### MPS 631RB/RF

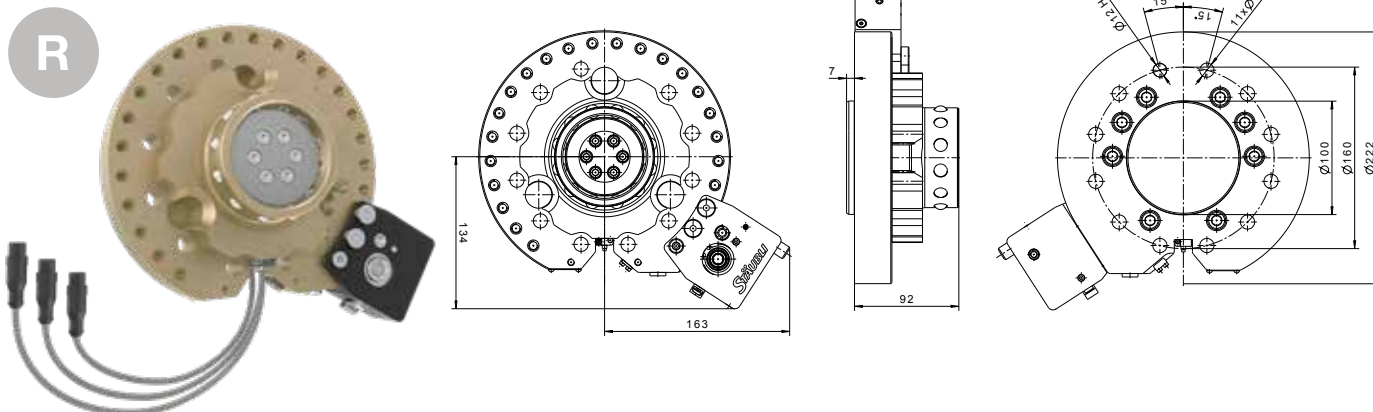

	Order no.	Pitch circle diameter (PCD)	Bending moment	Torsional moment	Payload	Compressed air connection	Safety module	Sensors/ connection	Module order code
R	K81557721	Ø 160 mm	5000 Nm	5000 Nm	630 kg	2x Push-lock hose-Ø 8 mm	-	3x PNP/ 3x M12	MPS631RA
	3x NPN/ 3x M12							MPS631RE	
R	K81557722	Ø 160 mm	5000 Nm	5000 Nm	630 kg	1x G3/8 Inner thread	Pressure switch PNP/NPN 1x M12	3x PNP/ 3x M12	MPS631RB
	3x NPN/ 3x M12							MPS631RF	

MPS 631RC/RG

R

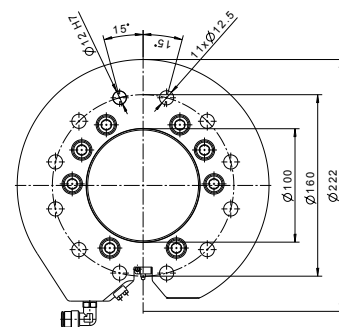
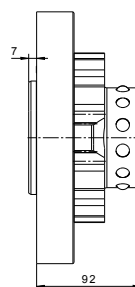
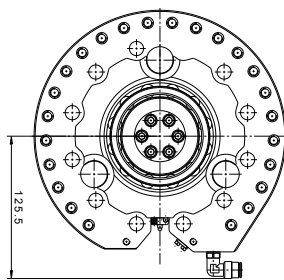

MPS 631RD/RH

R

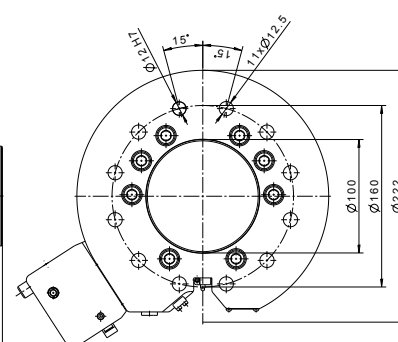
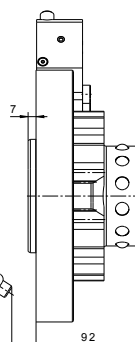
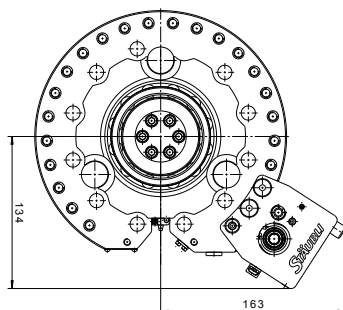

	Order no.	Pitch circle diameter (PCD)	Bending moment	Torsional moment	Payload	Compressed air connection	Safety module	Sensors/ connection	Module order code
R	K81557724	Ø 160 mm	5000 Nm	5000 Nm	630 kg	2x Push-lock hose-Ø 8 mm	-	3x PNP/ 1x M12 8-pole	MPS631RC
	K81557747							3x NPN/ 1x M12 8-pole	MPS631RG
R	K81557726	Ø 160 mm	5000 Nm	5000 Nm	630 kg	1x G3/8 Inner thread	Pressure switch PNP/NPN 1x M12	3x PNP/ 1x M12 8-pole	MPS631RD
	K81557748							3x NPN/ 1x M12 8-pole	MPS631RH

MPS 631 MODULAR

# MPS 631 base unit tool side - 3200 Nm

MPS 631TO

T

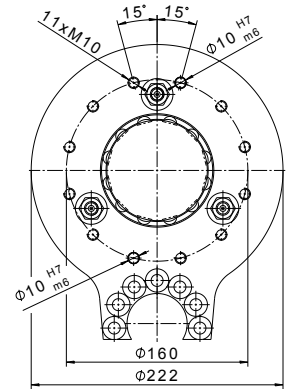
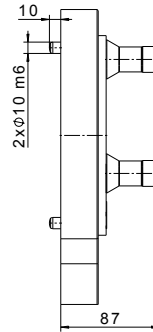
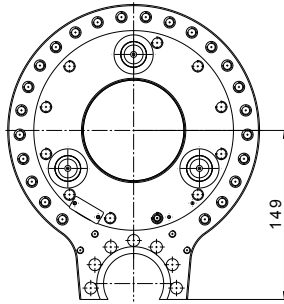

MPS 631TB

T

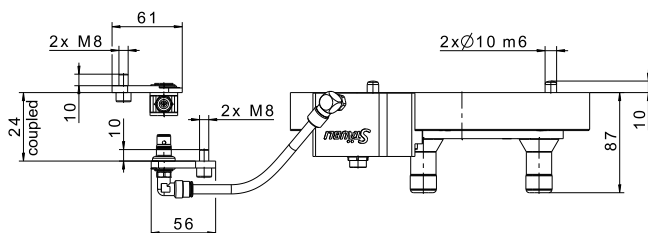
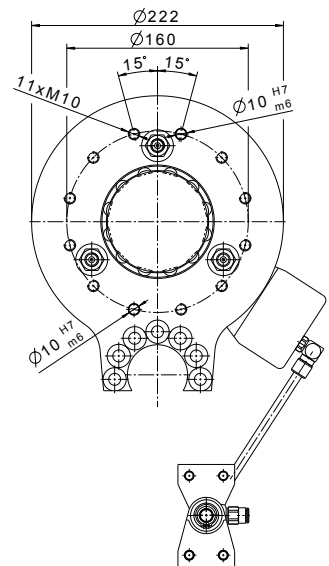
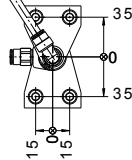
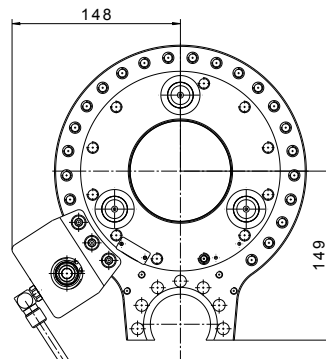

MPS 631TA

T

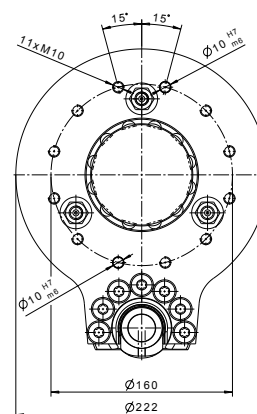
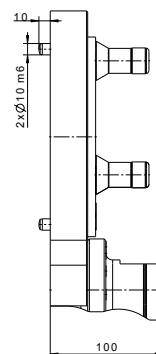
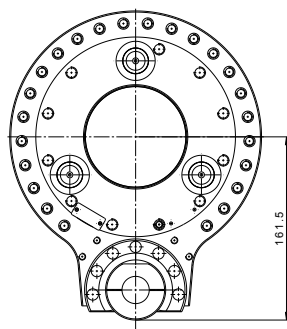

MPS 631TC

T

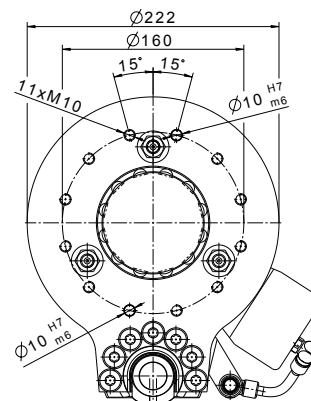
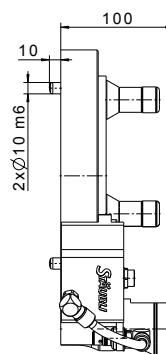
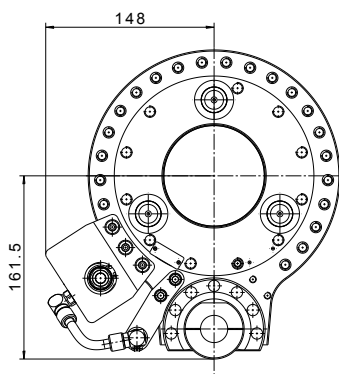

	Order no.	Pitch circle diameter (PCD)	Bending moment	Torsional moment	Docking hook	Safety module	Module order code
T	K81557705	Ø 160 mm	3200 Nm	3200 Nm	No	No	MPS631TO
T	K81557925	Ø 160 mm	3200 Nm	3200 Nm	No	Yes	MPS631TB
T	K81557920	Ø 160 mm	3200 Nm	3200 Nm	Yes	No	MPS631TA
T	K81557927	Ø 160 mm	3200 Nm	3200 Nm	Yes	Yes	MPS631TC

MPS 631 MODULAR

# MPS 631S base unit tool side - 5000 Nm

MPS 631TD

T

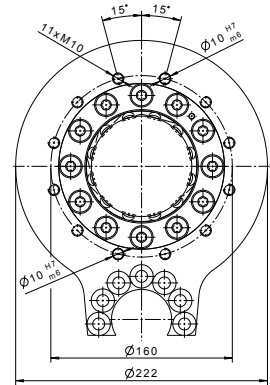
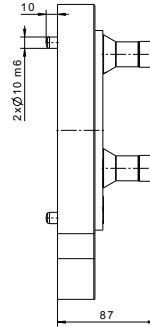
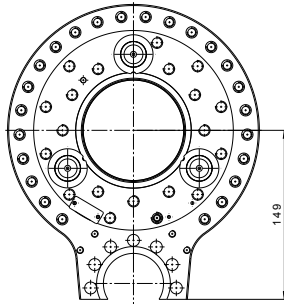

MPS 631TE

T

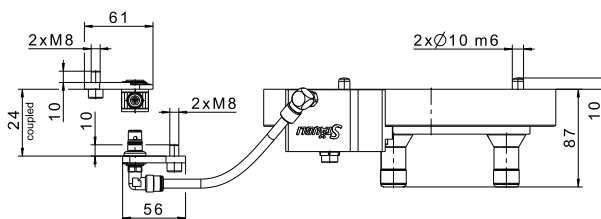
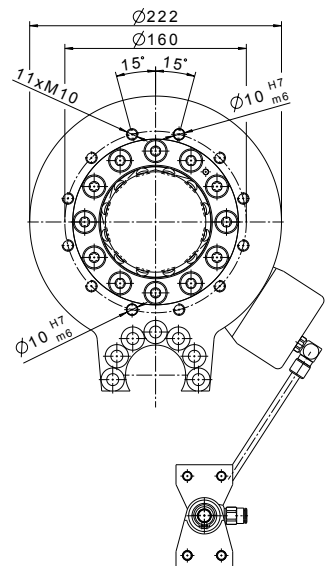
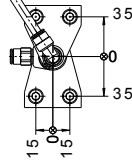
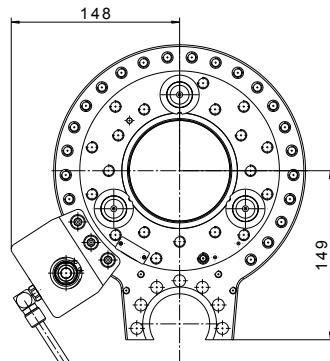



MPS 631TF

T

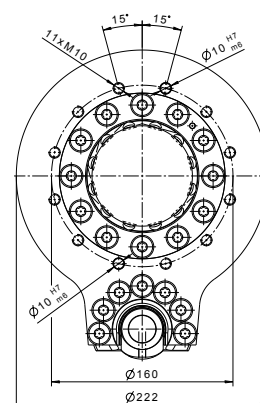
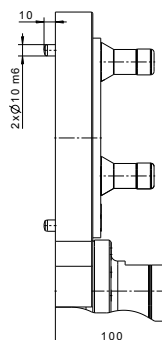
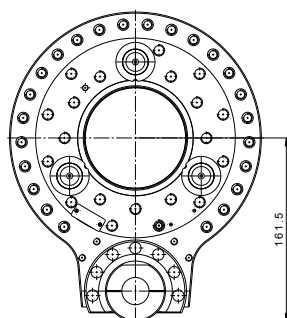

MPS 631TG

T

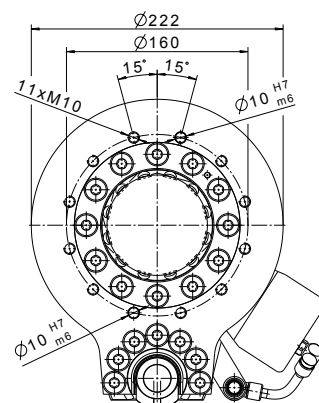
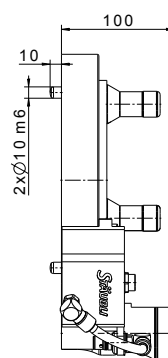
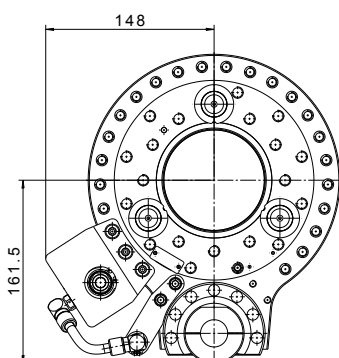

	Order no.	Pitch circle diameter (PCD)	Bending moment	Torsional moment	Docking hook	Safety module	Module order code
T	K81557921	Ø 160 mm	5000 Nm	5000 Nm	No	No	MPS631TD
T	K81557926	Ø 160 mm	5000 Nm	5000 Nm	No	Yes	MPS631TE
T	K81557922	Ø 160 mm	5000 Nm	5000 Nm	Yes	No	MPS631TF
T	K81557928	Ø 160 mm	5000 Nm	5000 Nm	Yes	Yes	MPS631TG

# MPS 631 Robot adapter flange

R

ill.1

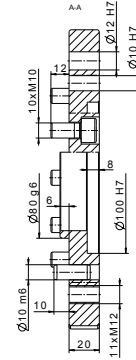
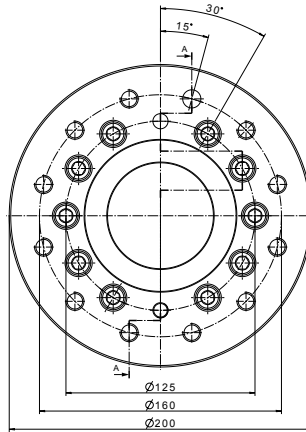

ill.2

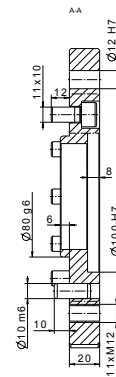
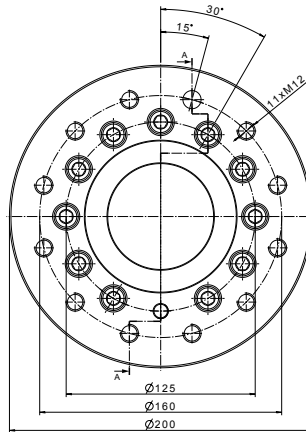

ill.3

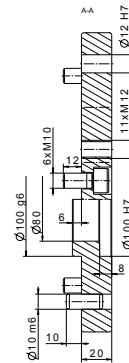
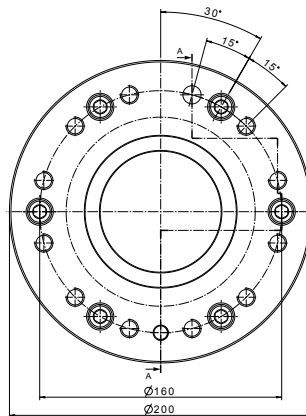

R

ill.4

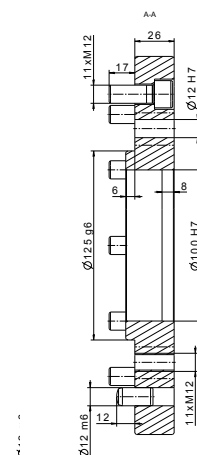
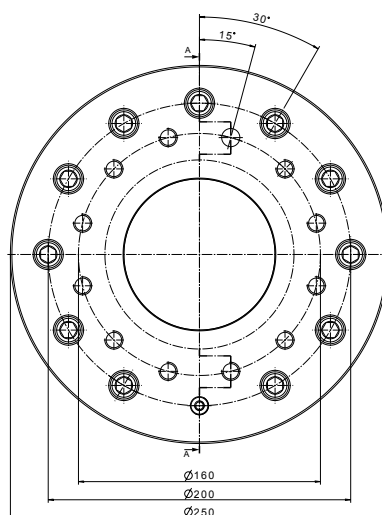

ill.5

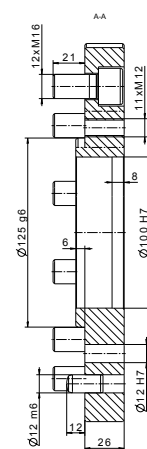
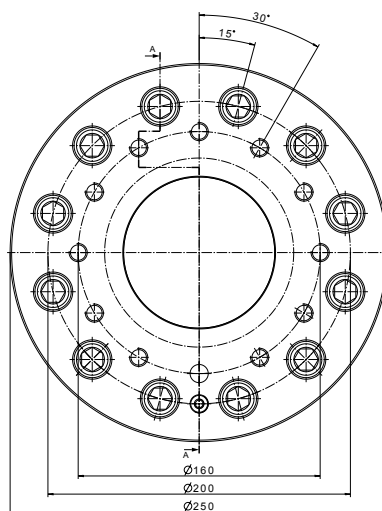

ill.	Order no.*	Adaption to	Zero offset
R 1	K81558266	ISO 9409-1-125-10-M10	15°
R 2	K81558267	ISO 9409-1-125-11-M10	15°
R 3	K81558268	ISO 9409-1-160-6-M10	15°
R 4	K81558269	ISO 9409-1-200-11-M12	15°
R 5	K81558270	ISO 9409-1-200-12-M16	0°

\* including mounting material.

## MPS 631 ACCESSORIES

# MPS 631 Accessories

### Robot side mounting kit



Order no.	Pitch diameter	Mounting materials	Strength class*	Locating pin
K81560744	Ø 160 mm	(11x) M10x50	12.9	(1x) 10/20
K81560745	Ø 160 mm	(11x) M12x45	12.9	(1x) 12/24

\* The specifications of the robot manufacturers must be observed. If the specifications are different, use the corresponding strength classes.

### Emergency release



Order no.	Description
K81558229	Tool for emergency release

### Teaching aid



Order no.	Description
K86301999	Teaching aid for the robot tool change system
K81557693	Storage case including teaching aid for the robot tool change system

## MPS 631 TOOL STAND COMPLETE

# MPS 631 – Tool stand

Flexibility and efficiency due to integrated tool storage

**The tool stand is consistent with Stäubli’s modular tool changer concept.**

**Its individual components are designed to provide maximum scope for flexibility.**

- Flexibility: the separate system components allow you to compile your own individual storage solutions.
- Optimisation: the complete systems are already dimensioned and calibrated for tool weights.
- Performance Level d, Category 3 compliant: the optional Active Docking System with self-contained compressed air circuit ensures that tool locking and unlocking can only take place at the tool stand.
- Longevity: the floating bearing of the docking pin holds the tool in the vertical storage position and minimises the load on the components.
- Function protection: a protective cover prevents any particles from getting into the transfer module couplings and connectors.



Contact us for **individual solutions** or **custom designs**.

Tool stand base	Positioning plate	Tool stand upper part	Protective cover	Sensors/ connection	Tool support	Electrical junction box	Order no.	ill.
H = 1400 mm	without	without Active Docking	without	3x PNP/ 3x M12	without	without	MPS631DA-0000-UP09-0000-0000-0000	1
				3x NPN/ 3x M12			MPS631DA-0000-UP11-0000-0000-0000	
H = 1400 mm	with	with Active Docking	without	3x PNP/ 3x M12	without	with	MPS631DA-OP02-UP10-0000-0000-0000-DB01	2
				3x NPN/ 3x M12			MPS631DA-OP02-UP12-0000-0000-0000-DB01	
H = 1400 mm	with	without Active Docking	with	3x PNP/ 3x M12	without	without	MPS631DA-OP02-UP09-PC05-0000-0000-0000	3
				3x NPN/ 3x M12			MPS631DA-OP02-UP11-PC07-0000-0000-0000	
H = 1400 mm	with	with Active Docking	with	3x PNP/ 3x M12	with	with	MPS631DA-OP02-UP10-PC06-0000-TS01-DB01	4
				3x NPN/ 3x M12			MPS631DA-OP02-UP12-PC08-0000-TS01-DB01	

Technical data for all the single components can be found on page 43.

# MPS 631 TOOL STAND COMPLETE

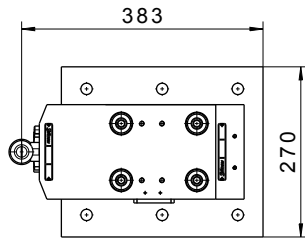

ill.1

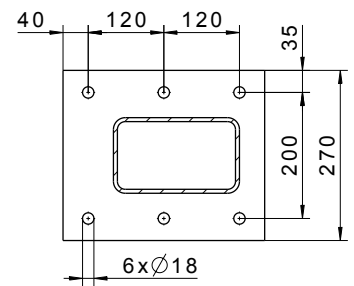
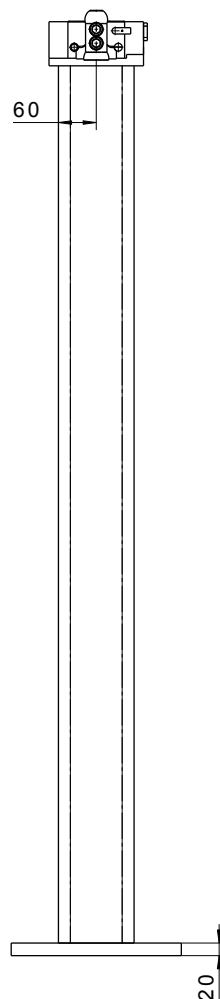
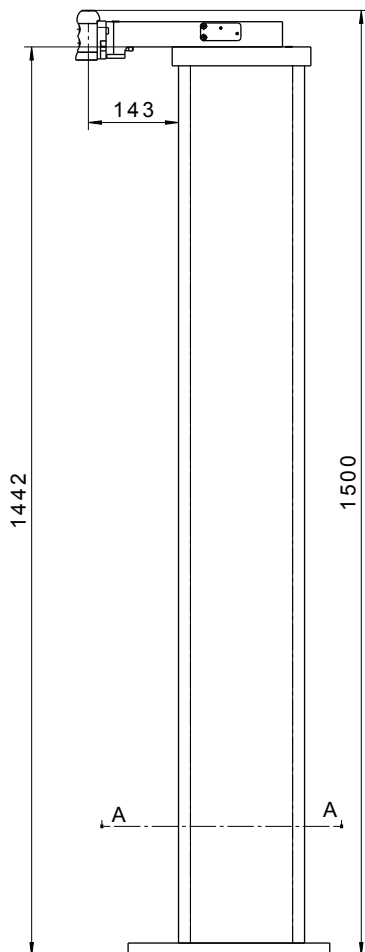

view A-A

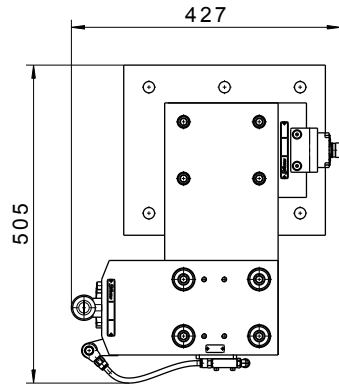

ill.2

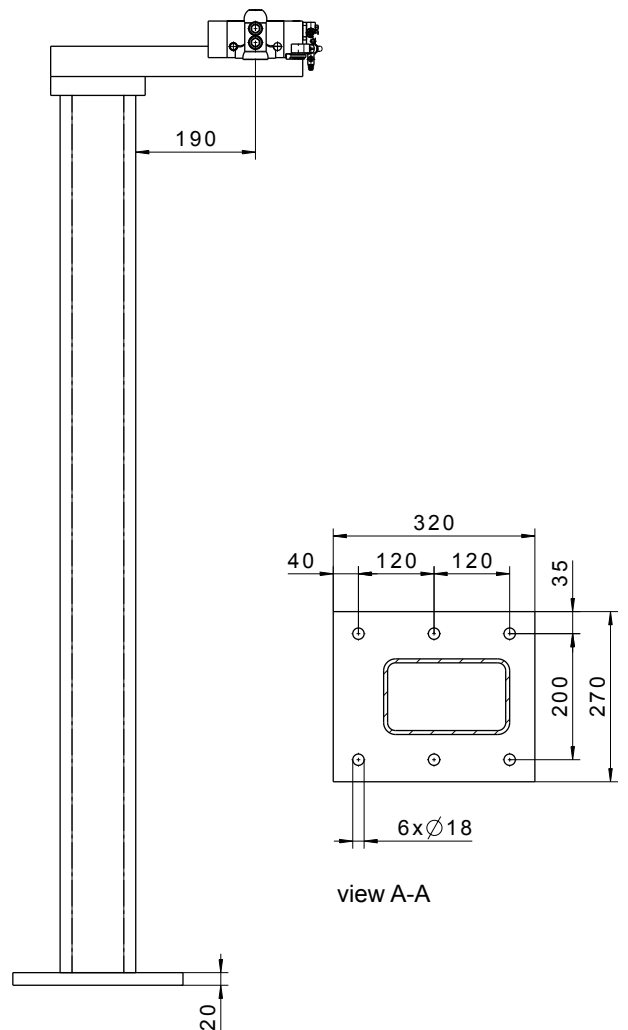
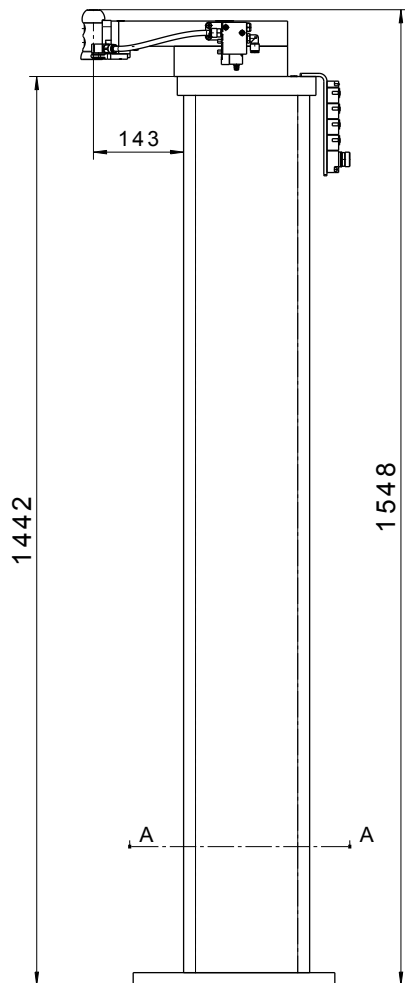

# MPS 631 TOOL STAND COMPLETE

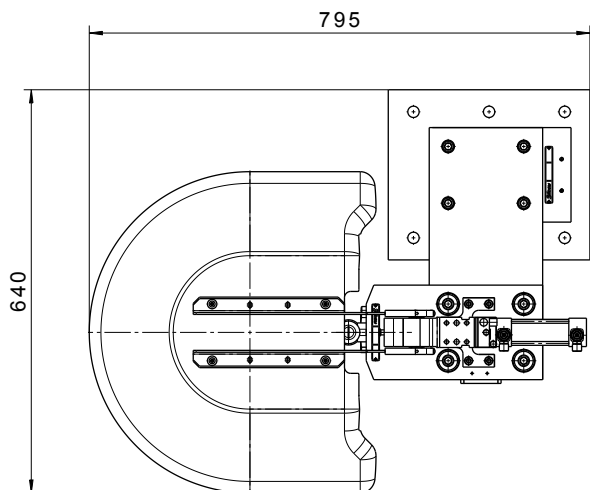

iii.3

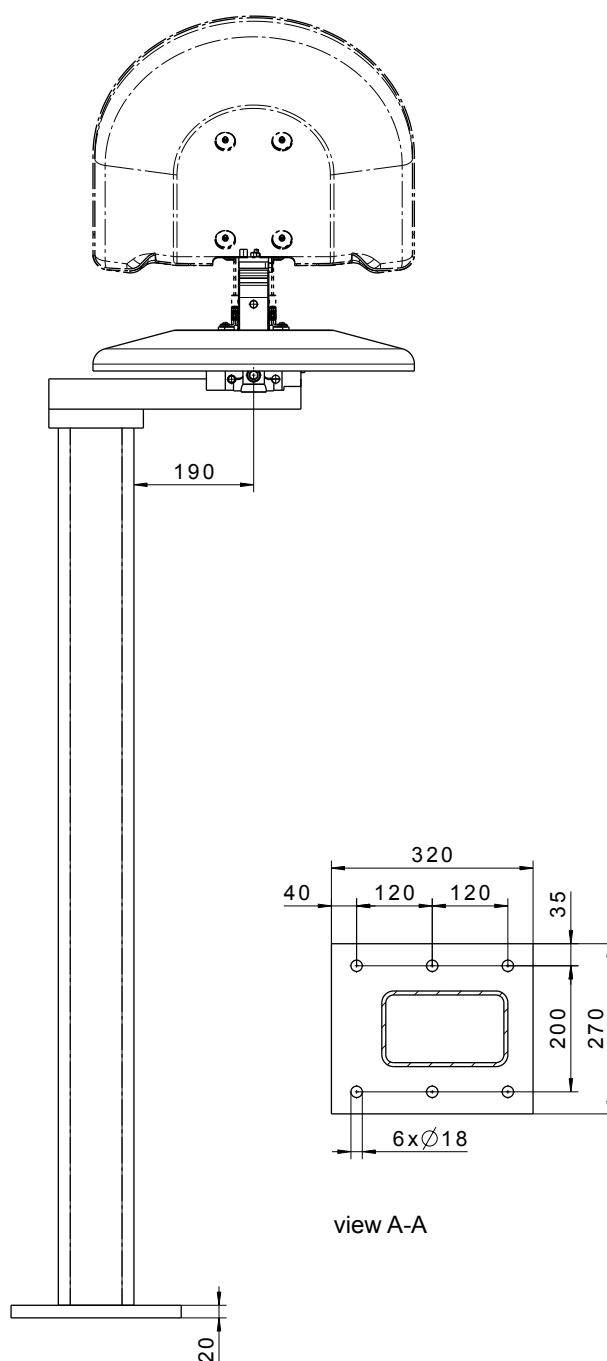
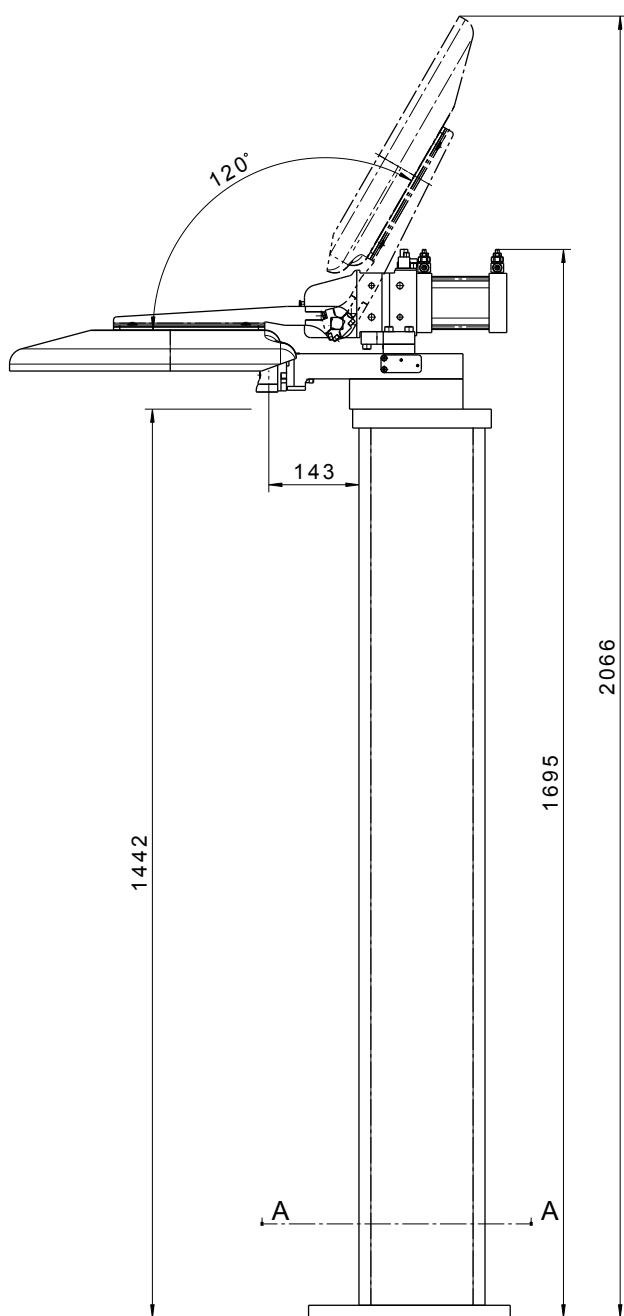



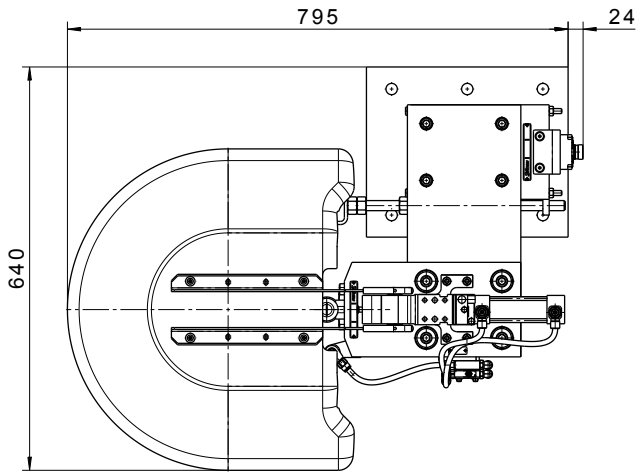

iii.4

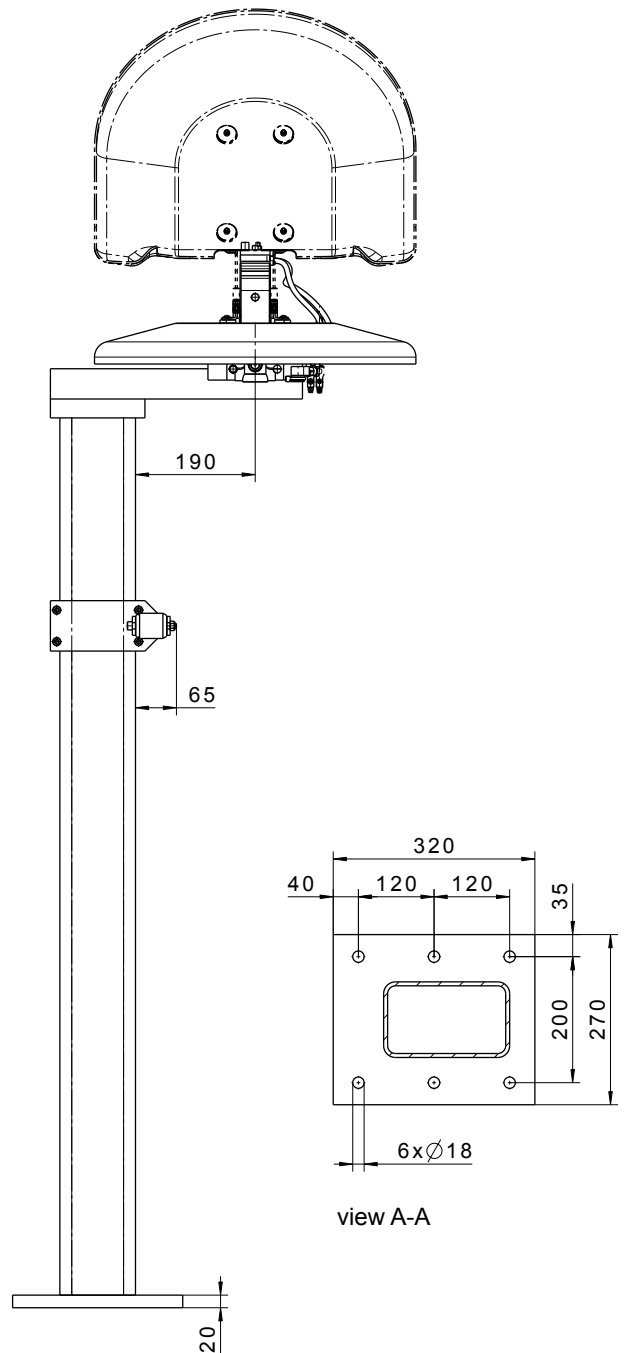
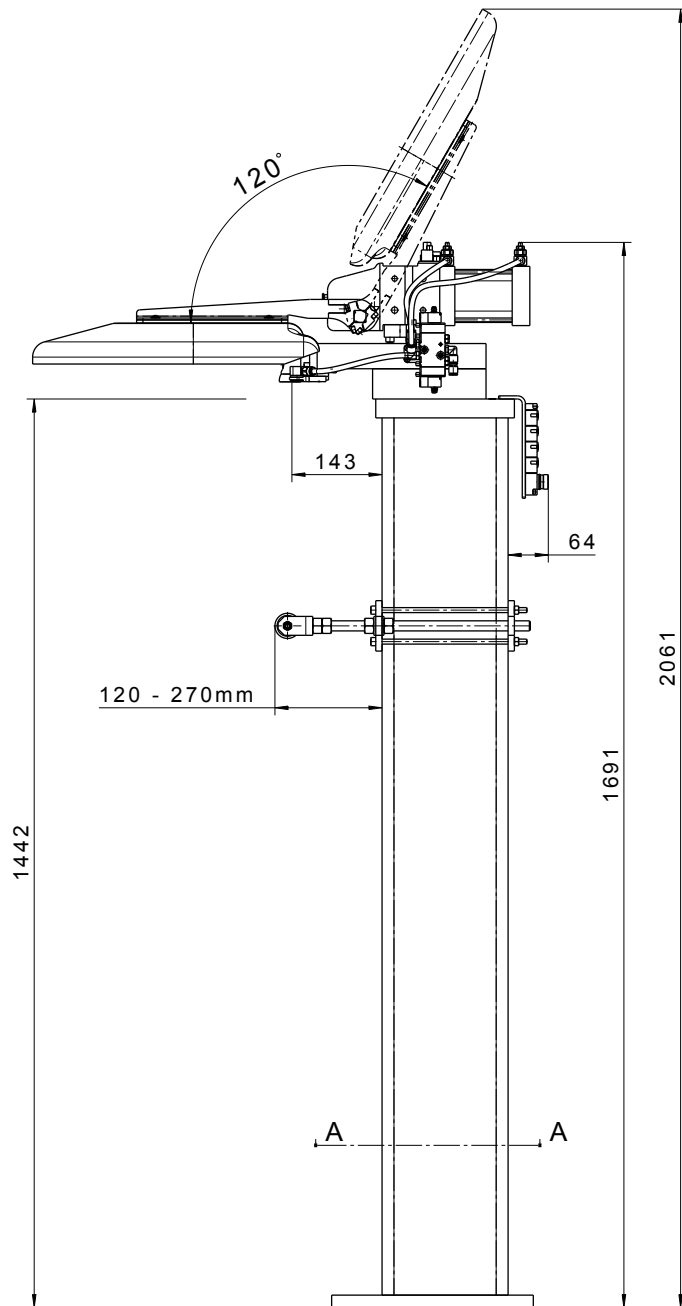

# MPS 631 – Tool stand

Your modular tool stand in a few simple steps

Take advantage of Stäubli's modular product concept for maximum design freedom.  
Configure your perfect tool stand in just a few steps.

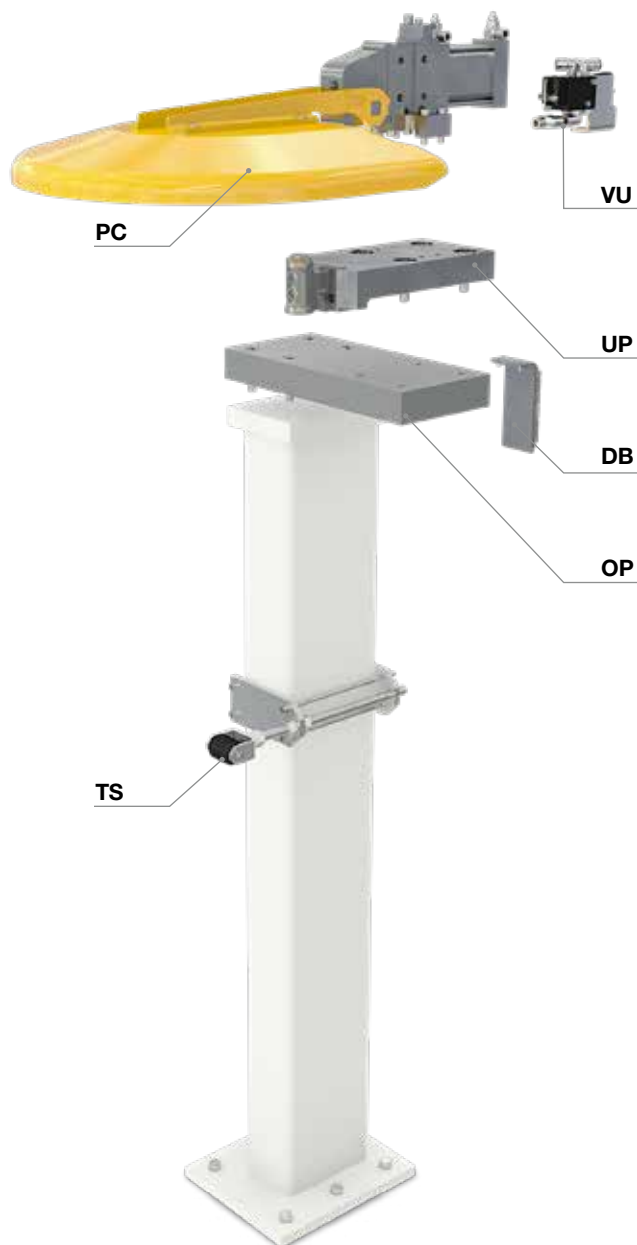

Select your **tool stand** and make a note of the module code.

Select your **module code** (page 43).

**OP** - Positioning plate

**UP** - Tool stand base

**PC** - Protective cover

**VU** - Valve unit

**TS** - Tool support

**DB** - Electrical junction box

Options that are not required are replaced in the code with 0000.

M P S 6 3 1 D A - O P 0 2 - U P 0 9 - P C 0 5 - V U 0 1 - T S 0 1 - D B 0 1  
M P S 6 3 1 D A O P U P P C V U T S D B

### Tool stand base

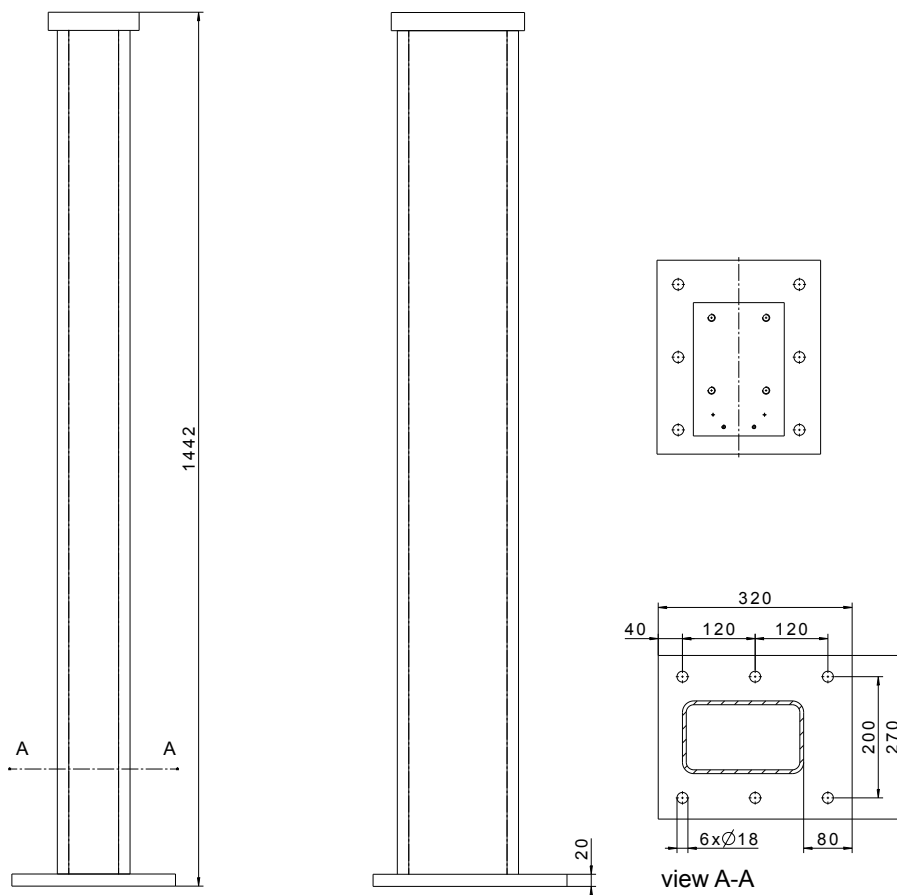

Order no.	Description	Module order code
K81904355	Tool stand base H = 1400 mm, RAL 9003	MPS631DA

### Positioning plate

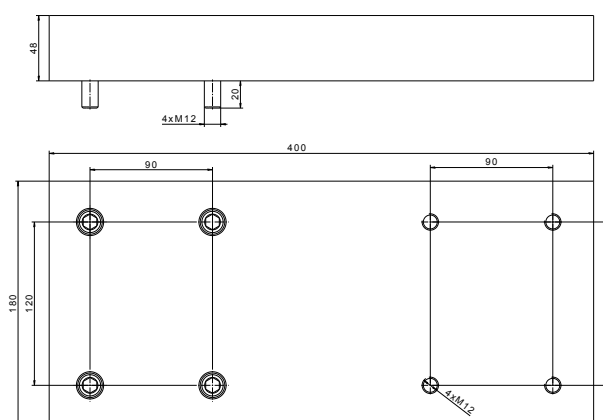

Order no.	Description	Module order code
K81558252	Positioning plate for expanding the storage options, includes mounting materials	OP02

# MPS 631 TOOL STAND MODULAR

## Tool stand upper part

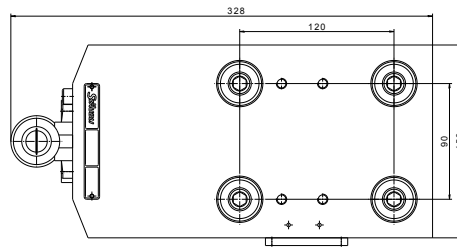
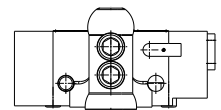
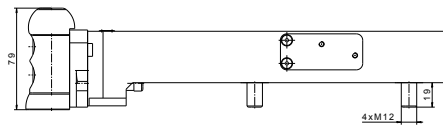

Order no.	Description	Sensors/ connection	Module order code
K86501448	Tool stand upper part, includes mounting materials	1x PNP/ 1x M12	UP09
K86501616		1x NPN/ 1x M12	UP11

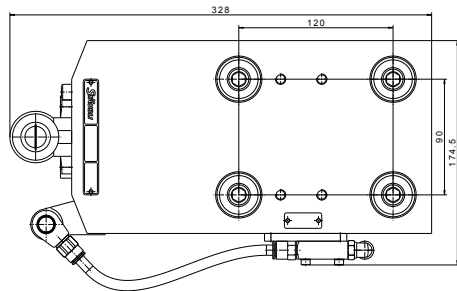
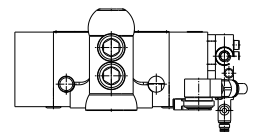
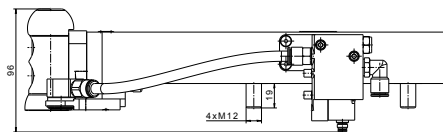

Order no.	Description	Compressed air connection	Sensors/ connection	Valve/ connection	Module order code
K86501661	Tool stand upper part with Active Docking, includes mounting materials and 3/2-way valve for actuation	1x Push-lock hose-Ø 8 mm	1x PNP/ 1x M12	1x M8 4-pole	UP10
K86501662			1x NPN/ 1x M12	1x M8 4-pole	UP12

## Protective cover

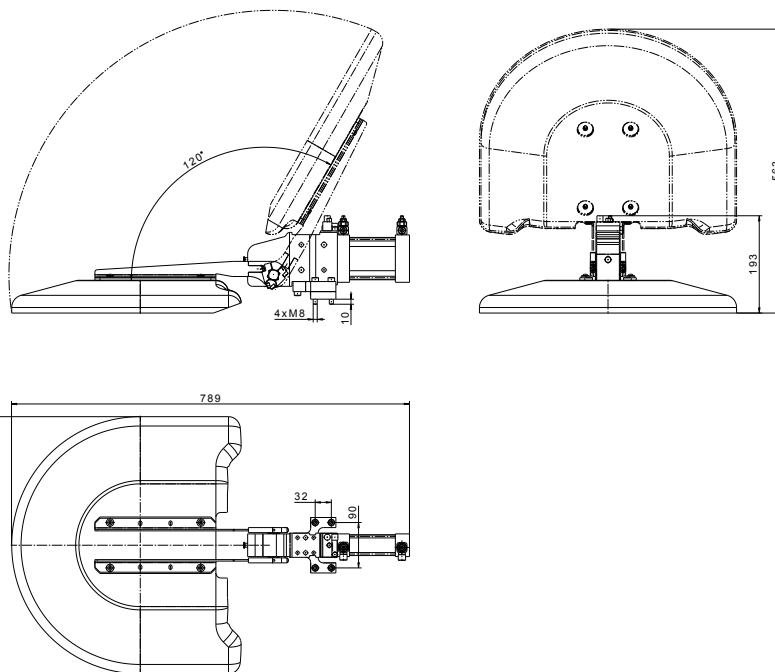

Order no.	Description	Compressed air connection	Sensors/ connection	Valve/ connection	Module order code
K81562427	Protective cover for harsh working environments; RAL 1003, includes mounting materials	2x Push-lock hose-Ø 8 mm	PNP/M12	–	PC05
K81562443			NPN/M12	–	PC07
K81562447	Protective cover for harsh working environments; RAL 1003, includes mounting materials and 3/2-way valve for actuation	2x Push-lock hose-Ø 8 mm	PNP/M12	2x M8 4-pol.	PC06
K81562448			NPN/M12	2x M8 4-pol.	PC08

## Tool support on the frame

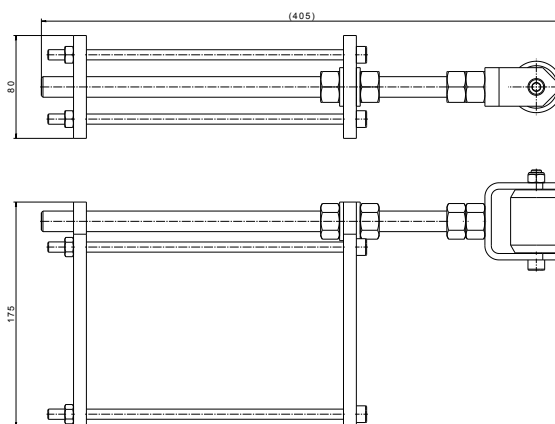

Order no.	Description	Adjusting range	Module order code
K85555053	Adjustable support roller for supporting larger tools with clamping function on stand frame for height variation and thread and counter function for depth variation	120-270 mm	TS01

# MPS 631 TOOL STAND MODULAR

## Electrical junction box

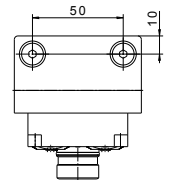
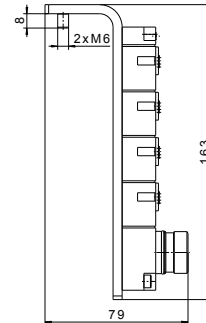
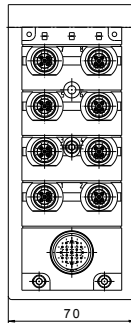

Order no.	Description	Input	Output	Module order code
K81565840	The electrical signals are bundled for integration in control and bus systems with LEDs for digital PNP signals 24V DC. Includes mounting plate for attachment to the tool stand.	8x M12 5-pole	Plug connection M23, 19-pin	DB01

The wiring diagram can be found on page 78.

## Valve assembly

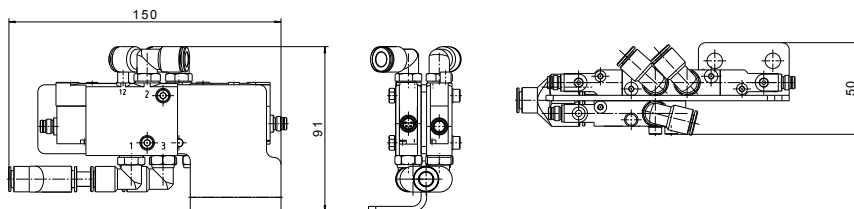

Order no.	Description	Electrical Connection	Compressed air connection	Module order code
K81565672	Control unit for protective cover and safety module 5/2 valve for protective cover, 3/2 valve for safety module, mounting plate for attachment to the tool stand	3x M8 4-pole	4x Push-lock hose-Ø 8 mm	VU01

The pneumatic diagram can be found on page 85.

## Docking pin

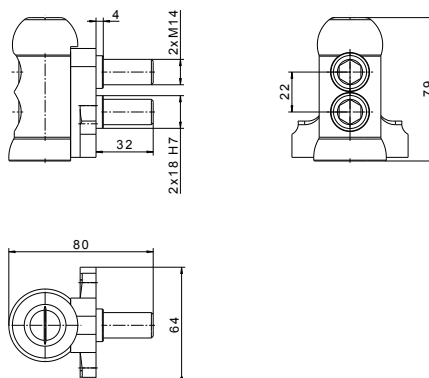

Order no.	Description
K81565792	Docking pin for self-assembly, includes mounting materials

## MPS 631 TRANSFER MODULES

# Transfer modules for your production technology

Transfer modules for fluid, pneumatic and vacuum connectors



from page 50 onwards

Transfer modules  
for hydraulic



from page 54 onwards

Transfer modules  
for tool coding



from page 55 onwards

Ground pin modules  
for shielding and earth connection



from page 56 onwards

Primary circuit modules  
for welding power transmission



from page 57 onwards



**MultiDNet-R electrical modules for signal and servo power transmission**



from page 62 onwards

**Integrated IDA bus module for system monitoring**



from page 58 onwards

**Active Docking safety module Performance Level d, Category 3**



from page 70 onwards

**CUSTOMIZED module for material feed-through, hydraulic, optical signals, signal and servo power transmission**



from page 72 onwards

# RMK transfer modules for pneumatics

## Technical description

- quick and easy replacement of the couplings
- large volume flows, low flow resistance
- extremely robust design guaranteeing a high number of mating cycles

R

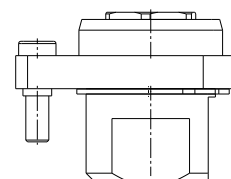
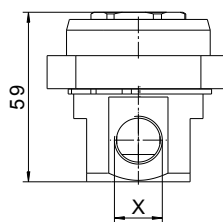
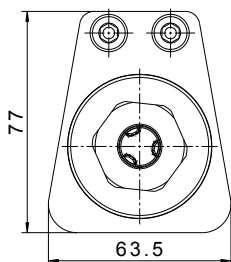

T

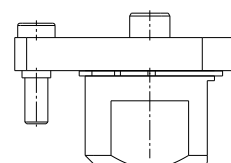
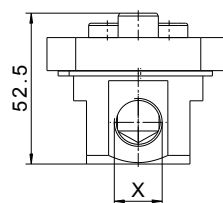
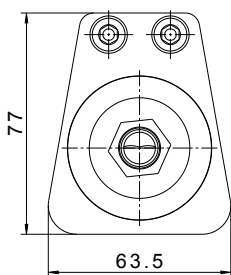

	Order no.	Nominal width	Circuits	Valve	Pressure (max.)	Flow rate	Connection (X)	Module order code
R	K81560784	11 mm	1	One-sided	1.0 MPa	200 Nm <sup>3</sup> /h	G 3/8 Inner thread	WM
T	K81560785			Free passage				
R	K81560827	11 mm	1	One-sided	1.0 MPa	200 Nm <sup>3</sup> /h	NPT 3/8 Inner thread	WO
T	K81560828			Free passage				
R	K81560829	11 mm	1	One-sided	1.0 MPa	200 Nm <sup>3</sup> /h	Rc 3/8 Inner thread	WP
T	K81560830			Free passage				

R

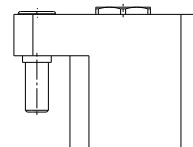
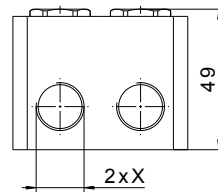
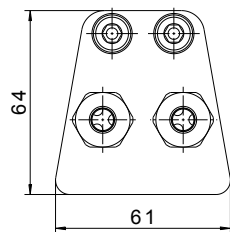

T

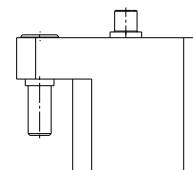
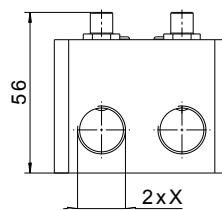
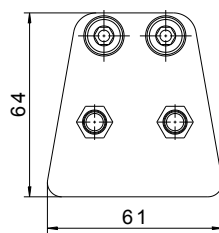

	Order no.	Nominal width	Circuits	Valve	Pressure (max.)	Flow rate	Connection (X)	Module order code
R	K81560786	6 mm	2	One-sided	1.0 MPa	67 Nm <sup>3</sup> /h	G 3/8 Inner thread	WQ
T	K81560787			Free passage				
R	K81560831	6 mm	2	One-sided	1.0 MPa	67 Nm <sup>3</sup> /h	NPT 3/8 Inner thread	WR
T	K81560832			Free passage				
R	K81560833	6 mm	2	One-sided	1.0 MPa	67 Nm <sup>3</sup> /h	Rc 3/8 Inner thread	WS
T	K81560834			Free passage				

## MPS 631 TRANSFER MODULES

# FTM transfer modules for pneumatics and vacuum

### Technical description

- free passage guarantees high volume flows with low flow resistance
- suitable for the transfer of up to 90% vacuum
- extremely robust design guaranteeing a high number of mating cycles

R

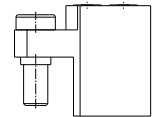
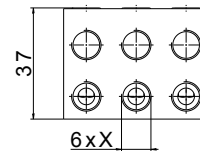
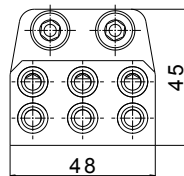

T

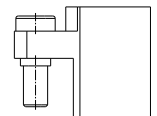
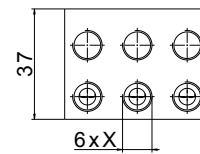
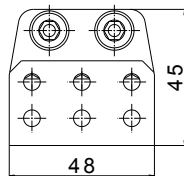

	Order no.	Nominal width	Circuits	Valve	Pressure (max.)	Flow rate	Connection (X)	Module order code
R	K81560731	5.5 mm	6	Free passage	1.0 MPa	37 Nm <sup>3</sup> /h	G 1/8 Inner thread	XA
T	K81560732							
R	K81560866	5.5 mm	6	Free passage	1.0 MPa	37 Nm <sup>3</sup> /h	NPT 1/8 Inner thread	XB
T	K81560867							
R	K81560868	5.5 mm	6	Free passage	1.0 MPa	37 Nm <sup>3</sup> /h	Rc 1/8 Inner thread	XC
T	K81560869							

# SPM transfer module for fluids and pneumatics

## Technical description

- clean-break technology for safe, leak-free media transfer
- no contamination of the workplace, no ingress of air into the media circuits
- cartridge system (Quick Change Inserts) for fast and easy maintenance
- large volume flows, low flow resistance

R

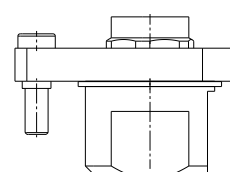
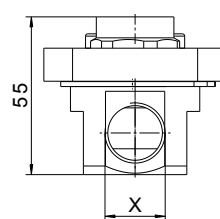
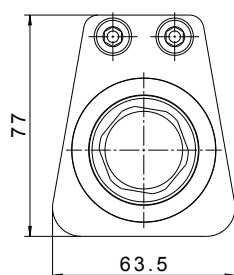

T

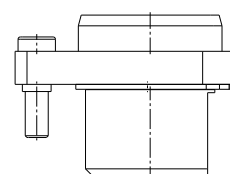
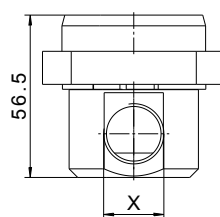
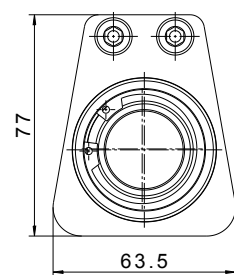

	Order no.	Nominal width	Circuits	Valve	Pressure (max.)	Flow rate	Connection (X)	Module order code
R	K81560780	12 mm	1	Both sides clean-break	1.6 MPa	40 l/min* 291 Nm <sup>3</sup> /h**	G 1/2 Inner thread	WT
T	K81560781							
R	K81560835	12 mm	1	Both sides clean-break	1.6 MPa	40 l/min* 291 Nm <sup>3</sup> /h**	NPT 1/2 Inner thread	WU
T	K81560836							
R	K81560837	12 mm	1	Both sides clean-break	1.6 MPa	40 l/min* 291 Nm <sup>3</sup> /h**	Rc 1/2 Inner thread	WV
T	K81560838							

\* for liquids at 5 m/s, \*\* for gases.

# SPC transfer modules for hydraulics

## Technical description

- clean-break technology for safe, leak-free media transfer
- no contamination of the workplace, no ingress of air into the media circuits
- cartridge system (Quick Change Inserts) for fast and easy maintenance
- large volume flows, low flow resistance

R

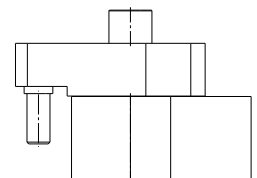
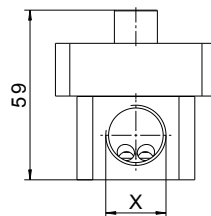
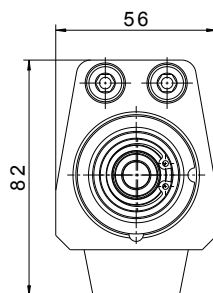

T

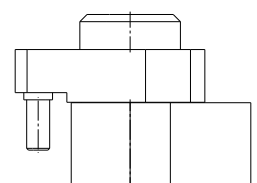
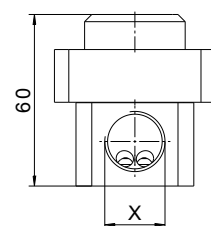
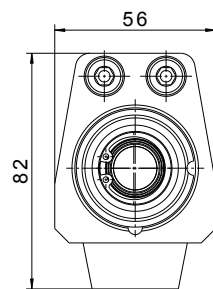

	Order no.	Nominal width	Circuits	Valve	Pressure* (max.)	Flow rate** (max.)	Connection (X)	Module order code
R	K81560728	8 mm	1	Both sides clean-break	25 MPa	15 l/min	G 3/8 Connecting thread	WW
T	K81560727							
R	K81560844	8 mm	1	Both sides clean-break	25 MPa	15 l/min	NPT 3/8 Connecting thread	WX
T	K81560843							
R	K81560846	8 mm	1	Both sides clean-break	25 MPa	15 l/min	Rc 3/8 Connecting thread	WY
T	K81560845							

\* The simultaneously occurring maximum pressure load of the coupled tool change system does not exceed 25 MPa.

\*\* Vmax. = 5 m/s; Cv=2,14.

# Transfer modules for tool coding

## Technical description

- individual coding of tool sides
- four inductive proximity switches on the robot side
- mechanical adjustment of the coding with an adjusting screw on the tool side

R

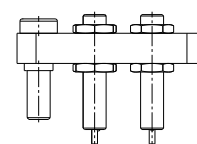
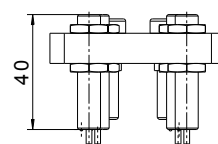
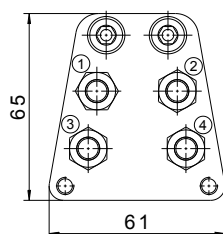

T

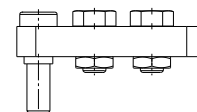
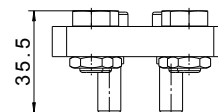
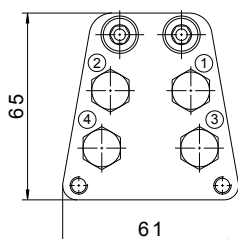

	Order no.	Sensors / connection	Module order code
R	K81560790	PNP/ 4x M8 3-pin - cable length 0.4 m	MS
T	K81560791	Mechanical opposing side	
R	K81565905	NPN/ 4x M8 3-pin - cable length 0.4 m	MT
T	K81560791	Mechanical opposing side	

## MPS 631 TRANSFER MODULES

# Ground pin modules for shielding and earth connection

### Technical description

- excellent power transmission with patented Stäubli MULTILAM technology
- Stäubli “Floating Contact Technology” guarantees wear-free connections
- low weight

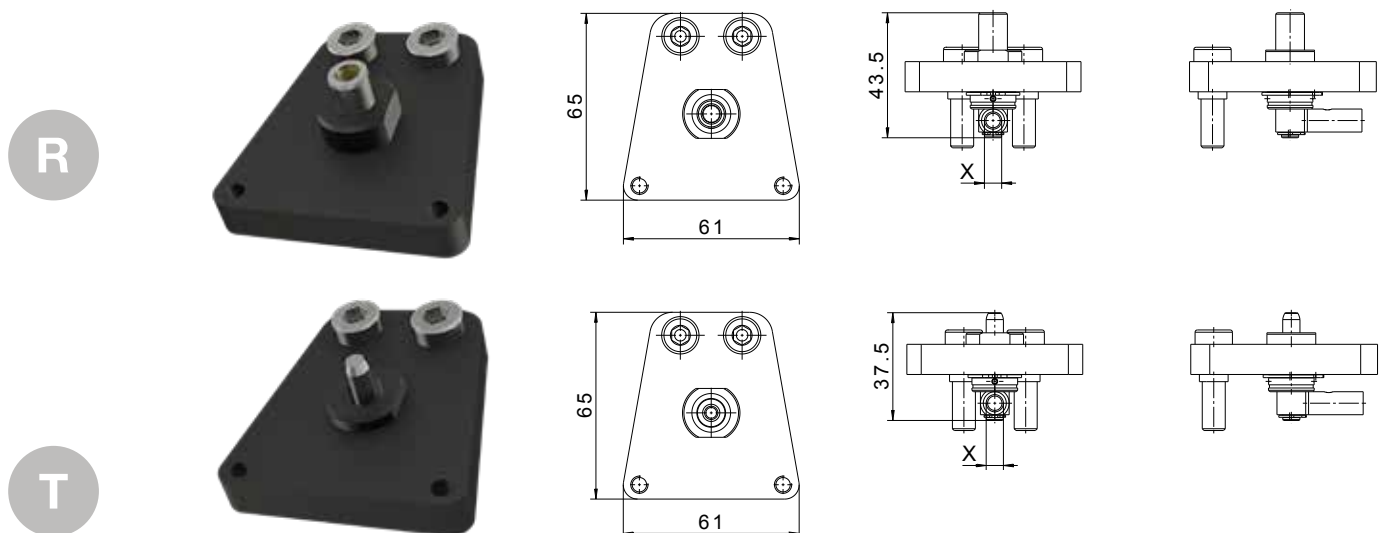

	Order no.	Transmission poles	Voltage/current	Cable cross-section	Connection (X)	Module order code
R	K81560792	1	55VAC/75A	10 mm <sup>2</sup>	crimp barrel	MR
T	K81560793					



# WPC4 Primary circuit modules for welding power transmission

## Technical description

- excellent power transmission with patented Stäubli MULTILAM technology
- suitable for high frequency transmission of up to 10 kHz with HF cables
- Stäubli “Floating Contact Technology” guarantees wear-free connections
- protection class: IP 65 (in a coupled state)

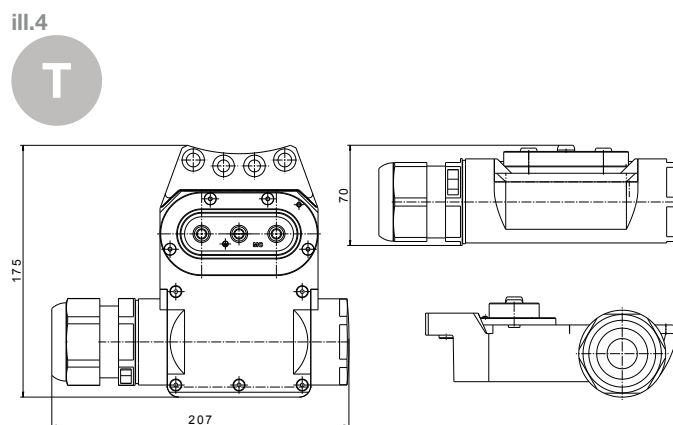
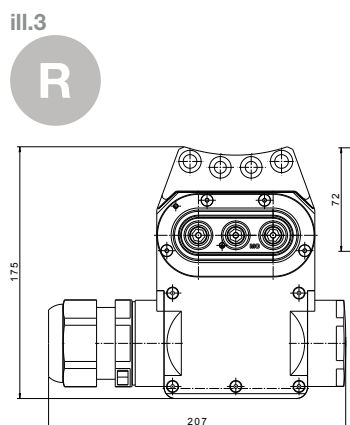
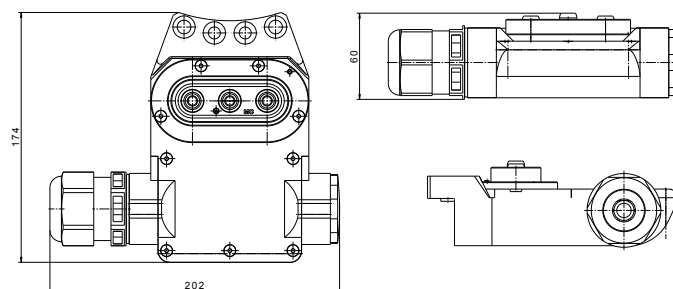
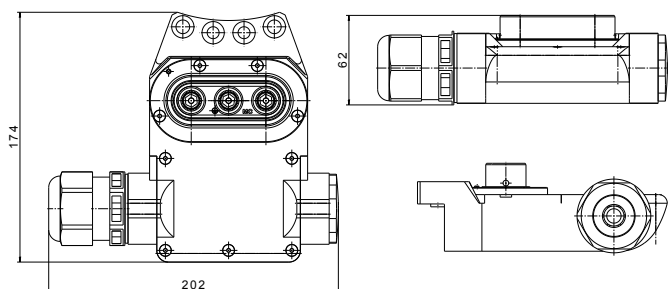

	Order no.	Transmission poles	Voltage/current	Cable cross-section	Screw	Clamping range	Module order code	ill.
R	K81560853	2+PE	1000VAC 135A/150A	25 mm <sup>2</sup> /35 mm <sup>2</sup>	M40x 1,5	19-28 mm	WPBA	1
T	K81560854							2
R	K81560855	2+PE	1000VAC 135A/150A/200A	25 mm <sup>2</sup> /35 mm <sup>2</sup> /50 mm <sup>2</sup>	M50x 1,5	21-35 mm	WPBB	3
T	K81560856							4

# Integrated bus module IDA for condition monitoring

The integrated IDA bus module is a freely programmable I/O module for network transmission housed in the MultiDNet-R electrical module. The IDA enables the space-saving and functional connection of the condition monitoring unit to the robotic tool changing system and to the next-higher control level.

Easy-to-read LED status displays and convenient web server configuration make the IDA even easier to use. An integrated current cut-off module for the 24V power supply prevents contact wear without any programming effort.

### Technical description

- compact design
- compatible with Modbus TCP, Ethernet/ IP and ProfiNet
- LEDs for operating states
- configuration with a web server
- freely programmable I/O module
- integrated 6 bit tool coding

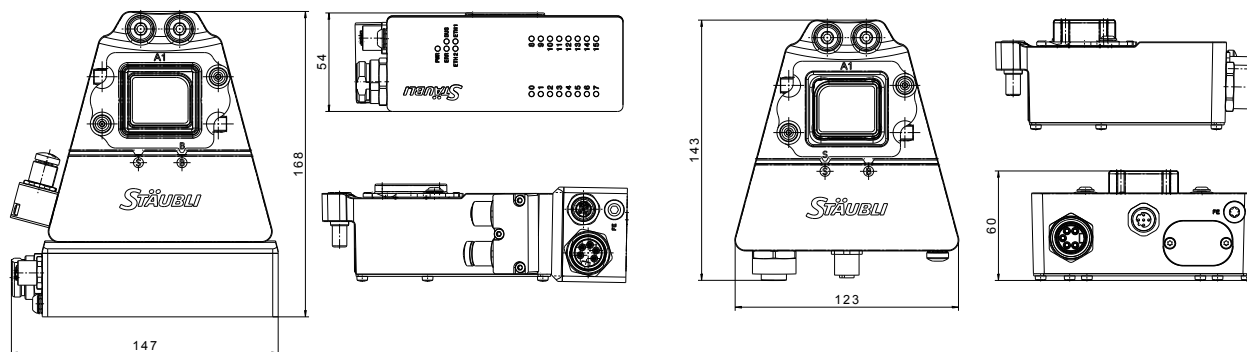

	Order no.	Description	Connection	Module order code	ill.
R	K81451532	Integrated bus module IDA for condition monitoring	7/8 5-pole	IDAA	1
T	K81451533		M12-D coded		2

The wiring diagram can be found on page 79.

The IDAA module can only be used in conjunction with the basic units of the robot side MPS 631RC and MPS 631RD.

## Accessories for connectors

	Order no.	Mating connector	Connection	Connection type	Suitable for
R	B27595660	straight cable output	7/8 5-pole	Screw terminal	IDAA
R	B27595985	straight cable output	M12-D coded		
T	B27595653	straight cable output	7/8 5-pole		
T	B27595985	straight cable output	M12-D coded		

# Integrated bus module IDA for condition monitoring

## Electrical and mechanical data

Supply	
Supply voltage	24 V DC
Permissible range	18 to 30 V DC
Power supply connection technology	Power supply connection 7/8 5-pole
Potential separation	Galvanic separation of the voltage groups V1- and AUX2, Dielectric strength up to 500 V DC

System data	
Fieldbus transfer rate	10 Mbps/ 100 Mbps
Fieldbus connection technology	Connection data M12-D coded
Automatic protocol recognition	Web server standard: 192.168.1.254
Service interface	ident. connection data M12-D coded

Modbus TCP	
Addressing	Static IP, BOOTP, DHCP
Function codes supported	FC1, FC2, FC3, FC4, FC5, FC6, FC15, FC16, FC23
Number of TCP connections	8
Input register start address	0 (0x0000 hex)
Output register start address	2048 (0x0800 hex)

Ethernet/IP	
Addressing	in accordance with Ethernet/IP™ specification
Quick Connect (QC)	< 500 ms
Device Level Ring (DLR)	supported
Number of TCP connections	3
Number of CIP connections	10
Input Assembly Instance	103
Output Assembly Instance	104
Configuration Assembly Instance	106

PROFINET	
Addressing	DCP
Conformance class	B (RT)
MiniCycleTime	1 ms
Fast Start-Up (FSU)	< 250 ms
Diagnostics	in accordance with PROFINET alarm handling
Topology recognition	supported
Automatic addressing	supported
Media Redundancy Protocol (MRP)	supported

## General data

<b>Standard/directive conformity</b>	
Electromagnetic compatibility	per EN 61131-2
<b>General information</b>	
Dimensions (W x L)	46 x 115 mm
Operating temperature	-40 to +45 °C
Storage temperature	-40 to +85 °C
Halogen-free	Yes

## MPS 631 TRANSFER MODULES

# MultiDNet-R electrical modules for signal and servo power transmission

### Technical description

- different modules for servo and signal version
- excellent power transmission with patented Stäubli MULTILAM technology
- robust contact technology
- protection class: IP 65 (in a coupled state)
- excellent shielding technology for secure data and power transmission

## Signal transmission ProfiNet

ill.1

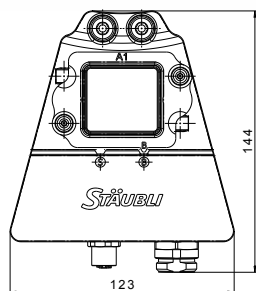

ill.2

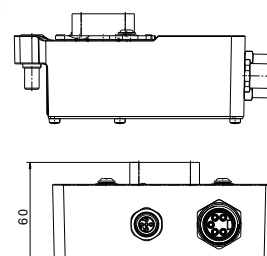
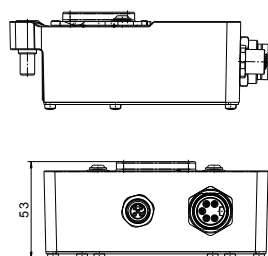
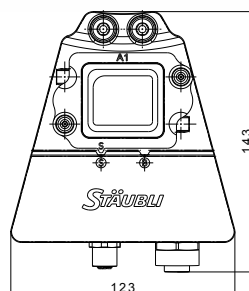

	Order no.	Transmission poles	Voltage/current (max.)	Connection	Module order code	ill.
R	K81451746	4+SH and 4+PE	250VAC/4A - 250VAC/6A	7/8" 5-pole, M12-D coded	ECBK	1
T	K81451747	4+SH and 4+PE	250VAC/4A - 250VAC/6A	7/8" 5-pole, M12-D coded		2

The wiring diagram can be found on page 80.

## Accessories for connectors

	Order no.	Mating connector	Connection*	Connection type	Suitable for
R	B27595660	straight cable output	7/8" 5-pol.	Screw terminal	ECBK
R	B27595985	straight cable output	M12-D coded		
T	B27595653	straight cable output	7/8" 5-pol.		
T	B27595985	straight cable output	M12-D coded		

\* Depending on the connection cable used, the max. number of poles that can be assigned may be reduced when assembling the connection plug. The connection cables are not included in the scope of delivery.

## Signal transmission Gigabit

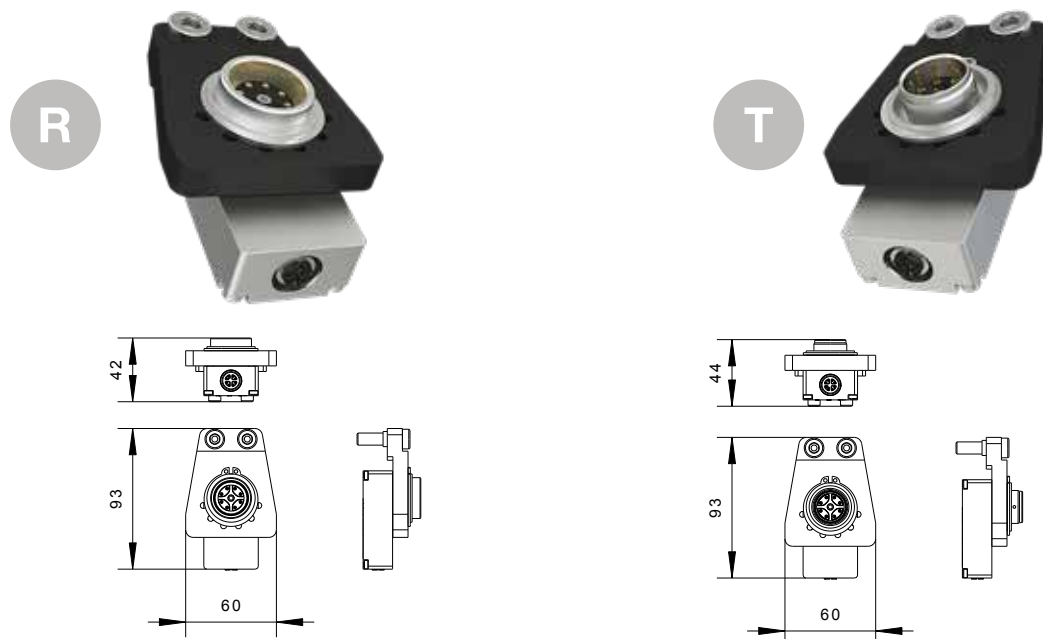

	Order no.	Type	Plug connection	Suitable for	Degree of protection	Description	Module order code
R	K81579314	Giga10 S90-RS-M12X	M12 socket x-coded	Network cable, Ethernet, CAT6A, 8 pin (10 GBit/s)	IP65	Pre-assembled and tested connector	EG
T	K81579315	Giga10 S90-TS-M12X					



According to the ProfiNet guidelines, the Gigabit electric module is equipped with a X-coded socket. Suitable for use in applications with Gigabit Ethernet and docked camera systems.

## MPS 631 TRANSFER MODULES

### Signal transmission and docking signals

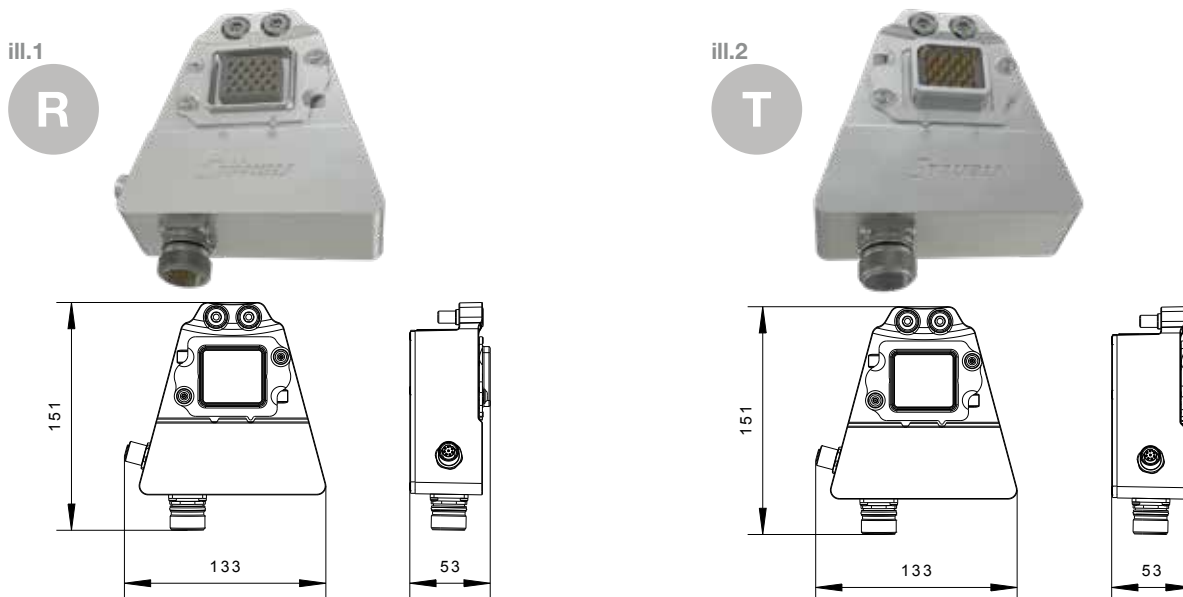

	Order no.	Transmission poles	Voltage/current (max.)	Connection	Module order code	ill.
R	K81452533	13 + dock signal	63VDC/63VAC - 7A	A EG A 560 MR 93 00 0201 400	ECBL	1
T	K81452535	13	63VDC/63VAC - 7A	A EG A 561 FR 91 00 0201 400		2

The wiring diagram can be found on page 80.

### Accessories for connectors

	Order no.	Mating connector	Connection*	Connection type	Suitable for
R	B27597873	straight cable output	A ST A 558 FR 92 73 0100 400	crimp barrel	ECBL
R	B27598497	90° cable output	A SD A 558 FR 91 58 0100 400		
T	B27598481	straight cable output	A ST A 559 MR 93 73 0100 400		
T	B27598589	90° cable output	A SD A 559 MR 93 42 0100 000		

\* Depending on the connection cable used, the max. number of poles that can be assigned may be reduced when assembling the connection plug. The connection cables are not included in the scope of delivery.



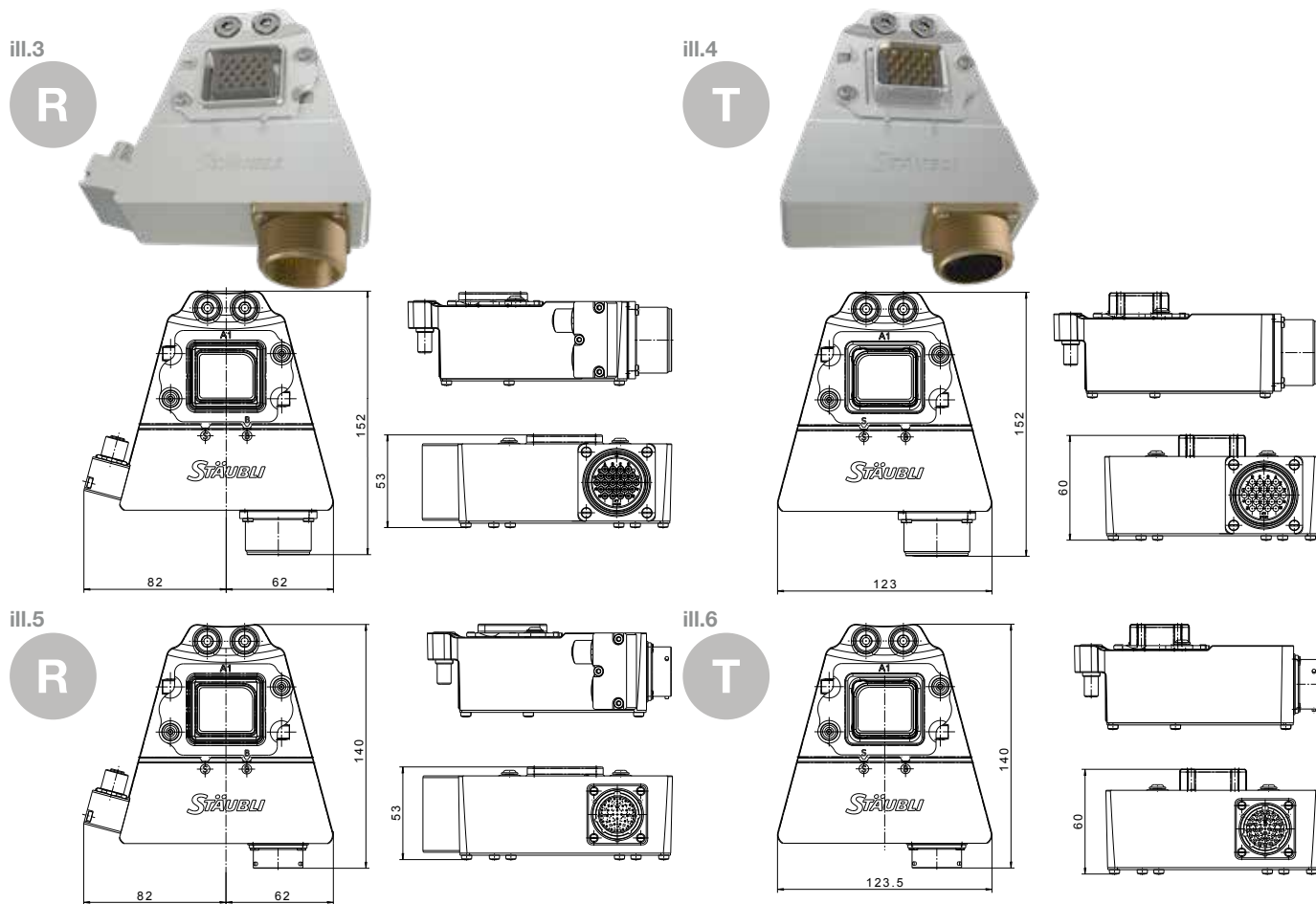

	Order no.	Transmission poles	Voltage/current (max.)	Connection*	Module order code	ill.
R	K81451299	18 + dock signal	60VDC/30VAC - 7.5A	CA3102E-24-28P	ECBI	2
T	K81451300	18	60VDC/30VAC - 7.5A	CA3102E-24-28S		3
R	K81451142	23 + dock signal	60VDC/30VAC - 7.5A	KPT2E18-32P	ECBB	4
T	K81451143	23	60VDC/30VAC - 7.5A	KPT2E18-32S		5

\* ITT Cannon, Amphenol and DDK are standardised connectors and plug-compatible. The wiring diagram can be found on page 81.

## Accessories for connectors

	Order no.	Mating connector	Connection**	Connection type	Suitable for
R	B27597976	straight cable output	CA3106E-24-28S	crimp barrel	ECBI
R	B27597978	90° cable output	CA3108E-24-28S		
T	B27597977	straight cable output	CA3106E-24-28P		
T	B27597979	90° cable output	CA3108E-24-28P		
R	B27597734	straight cable output	KPTC6F18-32S	crimp barrel	ECBB
R	B27597735	90° cable output	KPTC8F18-32S		
T	B27597737	straight cable output	KPTC6F18-32P		
T	B27597738	90° cable output	KPTC8F18-32P		

\*\* Depending on the connection cable used, the max. number of poles that can be assigned may be reduced when assembling the connection plug. The connection cables are not included in the scope of delivery.

## MPS 631 TRANSFER MODULES

### Signal transmission

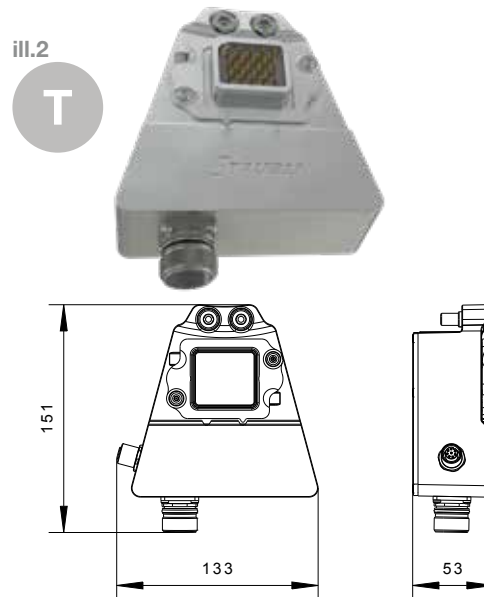
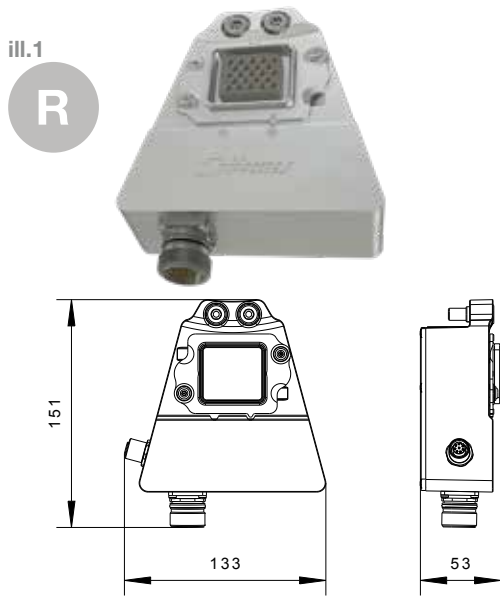

	Order no.	Transmission poles	Voltage/current (max.)	Connection	Module order code	ill.
R	K81452534	19	63VDC/63VAC - 7A	A EG A 560 MR 93 00 0201 400	ECBM	1
T	K81452535	19	63VDC/63VAC - 7A	A EG A 561 FR 91 00 0201 400		2

Den Verdrahtungsplan finden Sie auf Seite 82.

### Accessories for connectors

	Order no.	Mating connector	Connection*	Connection type	Suitable for
R	B27597873	straight cable output	A ST A 558 FR 92 73 0100 400	crimp barrel	ECBM
R	B27598497	90° cable output	A SD A 558 FR 91 58 0100 400		
T	B27598481	straight cable output	A ST A 559 MR 93 73 0100 400		
T	B27598589	90° cable output	A SD A 559 MR 93 42 0100 000		

ill.3



ill.4

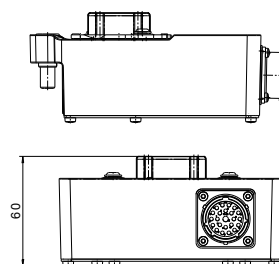
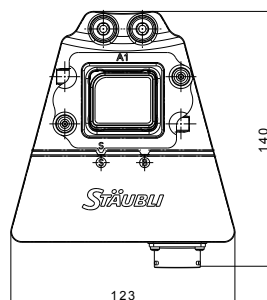
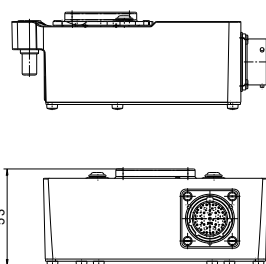
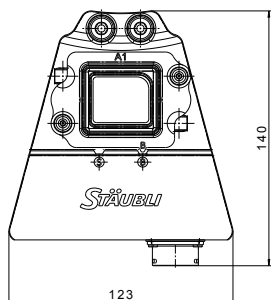

ill.5

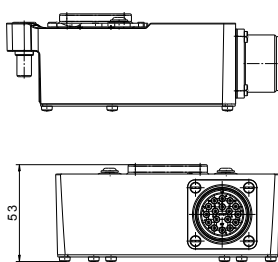
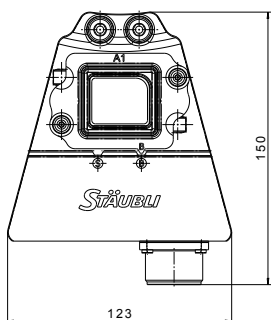

ill.6

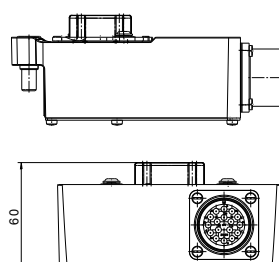
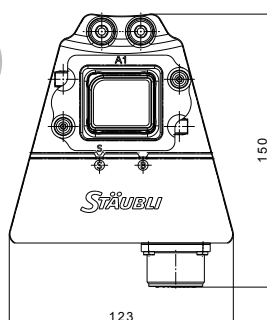

	Order no.	Transmission poles	Voltage/current (max.)	Connection*	Module order code	ill.
R	K81451303	23	60VDC/30VAC - 7.5A	KPT2E16-23P	ECBA	3
T	K81451304			KPT2E16-23S		4
R	K81451305	17	60VDC/30VAC - 7.5A	CA3102E-20-29P	ECBD	5
T	K81451306			CA3102E-20-29S		6

\* ITT Cannon, Amphenol and DDK are standardised connectors and plug-compatible. The wiring diagram can be found on page 83.

## Accessories for connectors

	Order no.	Mating connector	Connection**	Connection type	Suitable for
R	B27597727	straight cable output	KPTC6F16-23S	crimp barrel	ECBA
R	B27597728	90° cable output	KPTC8F16-23S		
T	B27597731	straight cable output	KPTC6F16-23P		
T	B27597732	90° cable output	KPTC8F16-23P		
R	B27597972	straight cable output	CA3106E-20-29S	crimp barrel	ECBD
R	B27597974	90° cable output	CA3108E-20-29S		
T	B27597973	straight cable output	CA3106E-20-29P		
T	B27597975	90° cable output	CA3108E-20-29P		

\*\* Depending on the connection cable used, the max. number of poles that can be assigned may be reduced when assembling the connection plug. The connection cables are not included in the scope of delivery.

## MPS 631 TRANSFER MODULES

### Servo power transmission

ill.1

R

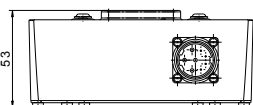
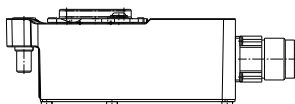
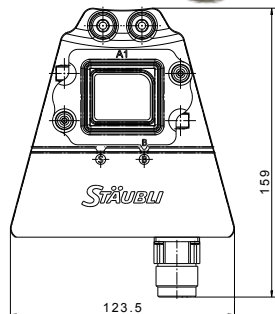

ill.2

T

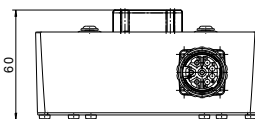
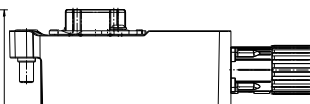
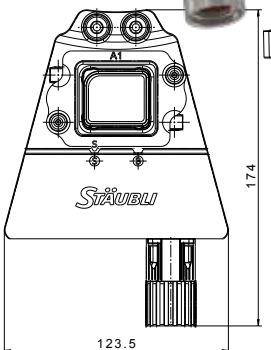

ill.3

R

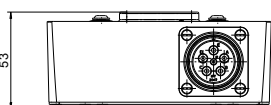
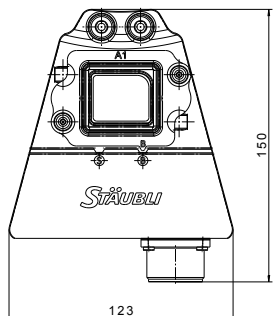

ill.4

T

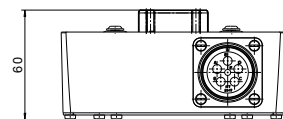
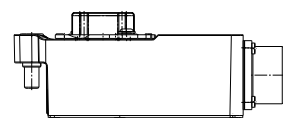
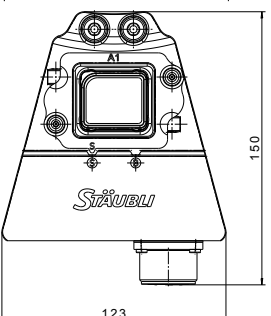

	Order no.	Transmission poles	Voltage/current (max.)	Connection*	Module order code	ill.
R	K81451144	3+PE	630VAC/VDC - 30A	B EG A 120 MR 11 00 0200 400	ECBC	1
T	K81451145	4	250VAC/VDC - 7A	B DF A 108 FR 05 00 0150 000		2
R	K81451301	3+PE	400VAC/VDC - 22A	CA3102E-20-17P	ECBF	3
T	K81451302	4	250VAC/VDC - 7A	CA3102E-20-17S		4

\* ITT Cannon, Amphenol and DDK are standardised connectors and plug-compatible.  
The wiring diagram can be found on page 84.

## Accessories for connectors

	Order no.	Mating connector	Connection**	Connection type	Suitable for
R	B27597360	straight cable output	B ST A 078 FR 05 42 0235 400	crimp barrel	ECBC
T	B27597414	straight cable output	B KU A 199 MR 38 42 0200 000		
R	B27597980	straight cable output	CA3106E-20-17S	crimp barrel	ECBF
R	B27597982	90° cable output	CA3108E-20-17S		
T	B27597981	straight cable output	CA3106E-20-17P		
T	B27597983	90° cable output	CA3108E-20-17P		

\*\* Depending on the connection cable used, the max. number of poles that can be assigned may be reduced when assembling the connection plug.  
The connection cables are not included in the scope of delivery.



# Active Docking safety modules

Performance Level d, Category 3

**Technical description**

- stand-alone system, independent of the bus system
- easy integration, lower system costs
- integrated pressure switch for locking pressure monitoring
- meets the safety requirements of Performance Level d, Category 3

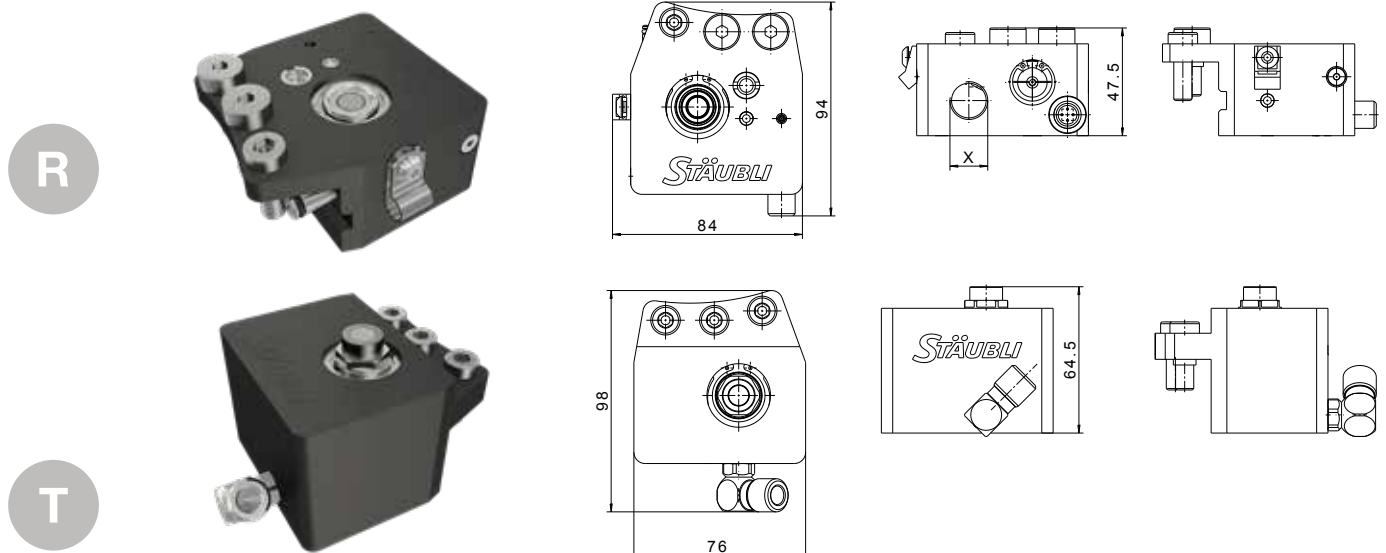

	Order no.	Sensors/connection		Compressed air connection (X)
R	K81565760	Pressure switch 4.5 bar/NO	PNP/ 1x M12	G3/8 Inner thread
R	K81565886	Pressure switch 4.5 bar/NO	NPN/ 1x M12	G3/8 Inner thread
T	K81565761	none		Push-lock hose outer-Ø 8 mm

## Transfer coupling MPS 631 tool stand

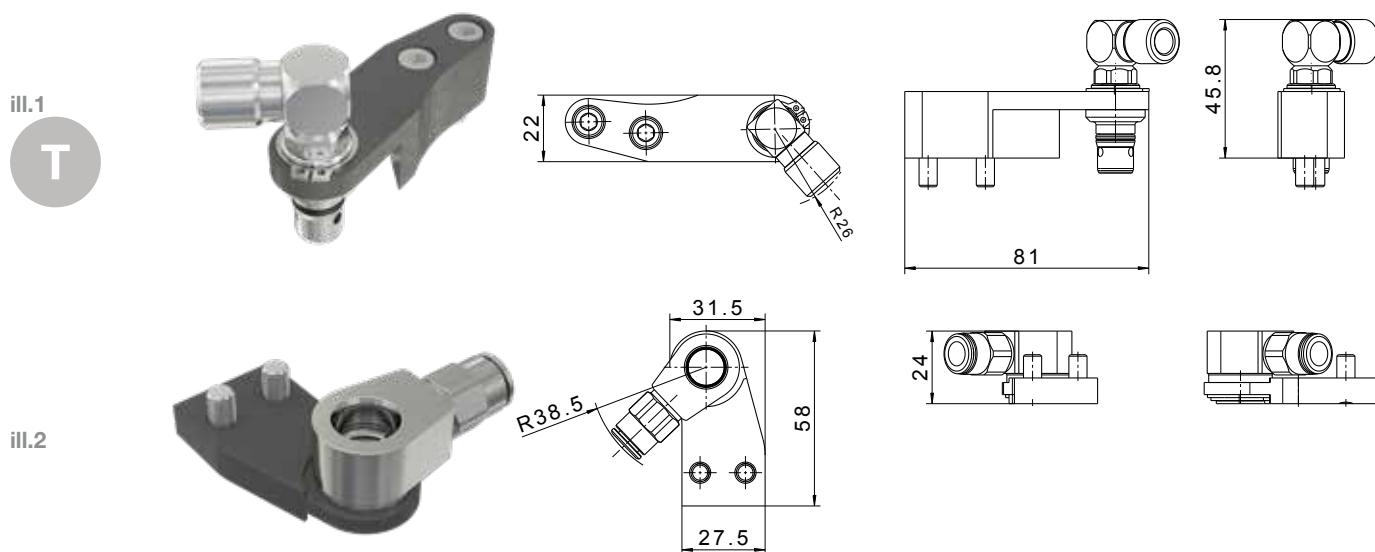

	Order no.	Accessories	Compressed air connection	ill.
T	K81565793	Transfer coupling for MPS 631	Push-lock hose outer-Ø 8 mm	1
	K81565659	Transfer coupling tool stand for MPS 631		2

## Transfer coupling external tool stand

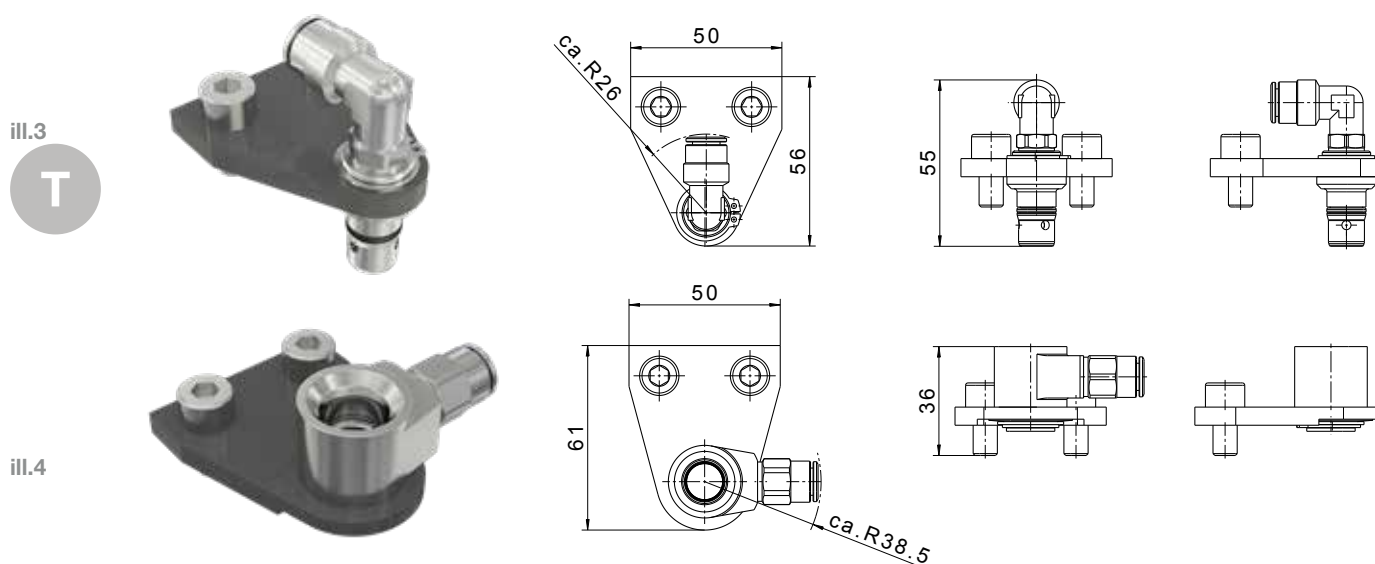

	Order no.	Accessories	Compressed air connection	ill.
T	K81564871	Transfer coupling for installation to end user tool	Push-lock hose outer-Ø 8 mm	3
	K81564872	Transfer coupling for installation to external tool stand		4

## MPS 631 TRANSFER MODULES

# CUSTOMIZED modules for special requirements

Signal and servo power transmission, light wave transmission, material feed-through and hydraulics for high-pressure applications: Stäubli offers individually designed CUSTOMIZED modules for these specialist and application-specific requirements.

## Transfer module MTM for material feed-through

### Technical description

- Possible transmission materials: screws, threaded bolts and rivets
- Individual designs corresponding to the manufacturer-specific transfer inserts



## Transfer module HVA 09 for hydraulic

### Technical description

- Coupling modules in clean-break design
- No contamination of the workplace, no ingress of air into the media circuit
- Quick-change system for simple and fast replacement of the couplings during a service
- Force decoupling of the hoses
- Low height
- Large volume flow rates, low flow resistance



Nominal width	Circuits	Valve	Pressure* (max.)	Flow rate** (max.)	Connection
9 mm	2	Both sides clean-break	25 MPa	114.5 l/min*	G 3/8, NPT 3/8, Rc 3/8 Inner thread

\* The simultaneously occurring maximum pressure load of the coupled tool change system does not exceed 25 MPa.

\*\*  $V_{max.} = 30 \text{ m/s}$ ;  $C_v=3,18$ .



## Transfer module LWL for optical signals

### Technical description

- Signal transmission using lens technology
- Unaffected by misalignment and axial deviation
- Automatic lens cover
- Wires protected by the robust coupling housing
- Identical parts for both base units
- Extremely low attenuation factor



Cable type	Connection
Duplex 1000 µm, polymer fibre cable 980/1000	2x FSMA

## Electrical module MultiDNet-R G3 for signal and servo power transmission

### Technical description

- three individually configurable contact chambers for servo and signal transmission
- excellent power transmission with patented Stäubli's MULTILAM technology
- malfunction-free and durable contact technology
- protection class: IP 65 (in coupled state)
- excellent shielding technology for reliable data and power transmission
- optional quick-change system



Type	Transmission poles	Voltage (max.)	Current (max.)	Applications
Signal	22+PE	24V	20A	Ethernet, Interbus, Profibus, audio, video
Servo	3+PE	690V	32A	Servo power transmission
	4	250V	20A	Bremse, signals

MPS 631 CUSTOMIZED TRANSFER MODULE

# Simple contact replacement CUSTOMIZED quick-change

R



**MultiLAM CUSTOMIZED quick-change contacts**



**Upper contact carrier**



**CUSTOMIZED quick-change insert**



**MultiDNet-R Metal housing**



**Contact carrier bracket**



**Lower contact carrier**



**MultiLAM crimp contacts**

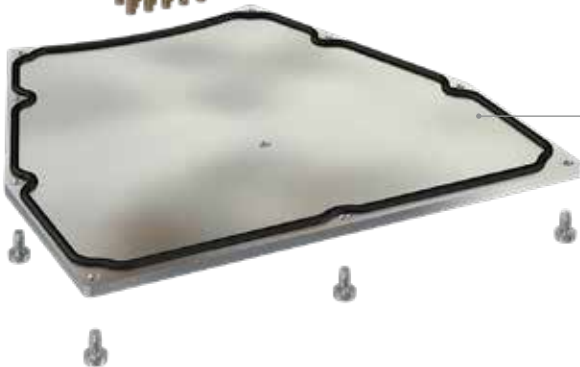

**Housing cover\***

\* Including mounting materials.



**A special product variant can be provided with welding current, data and signal transmission modules that are fitted with quick-change heads. The main advantage of this is quick and easy maintenance.**

Modules with quick-change heads are ideal for process applications with many change cycles. If the contacts in the electrical plug connector bushes malfunction, it is not necessary to replace the entire module. The intelligent cartridge system makes it possible to replace just the docking contacts.

**Convenient maintenance:**

Modules no longer have to be removed or cable connections disconnected for contact replacement. This shorter and easier maintenance procedure saves time and money, and reduces production downtime.

# Customer-specific designs



**Agile project management  
for maximum efficiency**

**Our 125 year-long commitment to innovation and our extensive expertise in all industrial sectors are reflected in our individual solutions for customers around the world. We liaise closely with our customers to develop custom-made systems that are precisely and flexibly adapted to their requirements.**

Over the decades, as a pioneer in the development of robotic tool changing systems, Stäubli has consistently implemented the highest precision and quality standards as well as maximum safety aspects with innovative, sustainable and variable technologies. Reflecting these high standards, the modular tool changers

have an open architecture that makes the customer-specific design of perfectly matched systems possible.

**Global cost efficiency and quality standards**

Companies and corporations rely on standard global production processes ensuring they maintain their own quality standards. This optimises the costs along the entire production resource supply chain. Stäubli consistently supports this approach by developing its own standards for customers with robotic tool changing systems.

**Design expertise from a single source**

All components of the robotic tool changer systems are developed and manufactured by Stäubli:

- Only proven and certified technologies are used, based on decades of experience, for the comprehensive portfolio of transfer modules and electrical connectors.
- All design, production and quality inspection activities take place within Stäubli.



**Know-how from design to finished product**

**Worldwide, individual, on-site advice**

- Stäubli personnel are available for individual consultations from all their worldwide locations.
- Our technical consultants analyse the production and operating conditions with you at your site.
- Our project planning and design specialists configure the MPS system to your requirements.

**Optimum system customisation for maximum productivity**

Stäubli implements specific requirements, such as locking units for special payloads or new, process-dependent transfer modules, in optimally adapted and technologically sophisticated systems.

The individual adaptation of the transfer modules is possible with almost all product parameters:

- Faster transfer rates due to larger nominal diameters
- Customized additions to the plug & play product range
- Special media resistance and robustness is achieved through the use of highly resistant and premium quality materials
- Customer-specific wiring of electrical connectors with component testing and logging
- Development of new transfer modules for specific production technologies



**Comprehensive payload range**

Stäubli caters for a broad spectrum of payloads from 10 to 1530 kilogrammes and enabling a wide range of applications. Please contact us if the payloads listed in this brochure do not meet your needs.

# WIRING DIAGRAMS

## DB01 - Electrical junction box

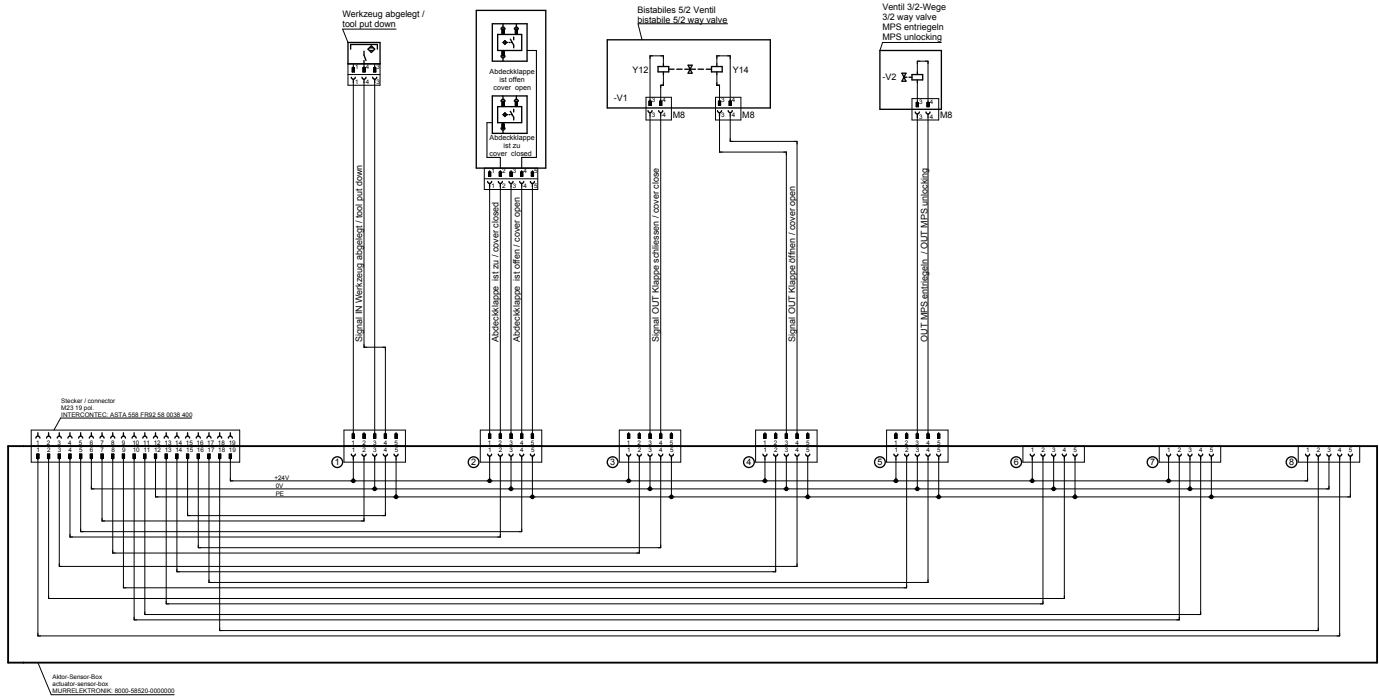

# IDAA - integrated IDA 631 bus module

iii.2

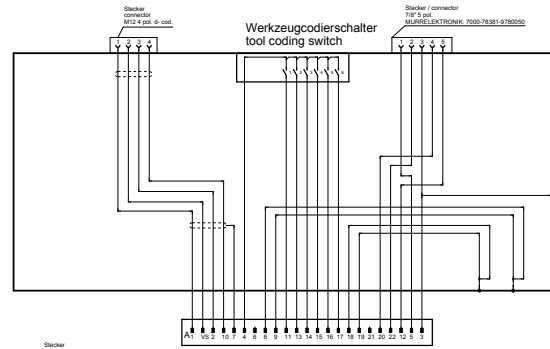

iii.1

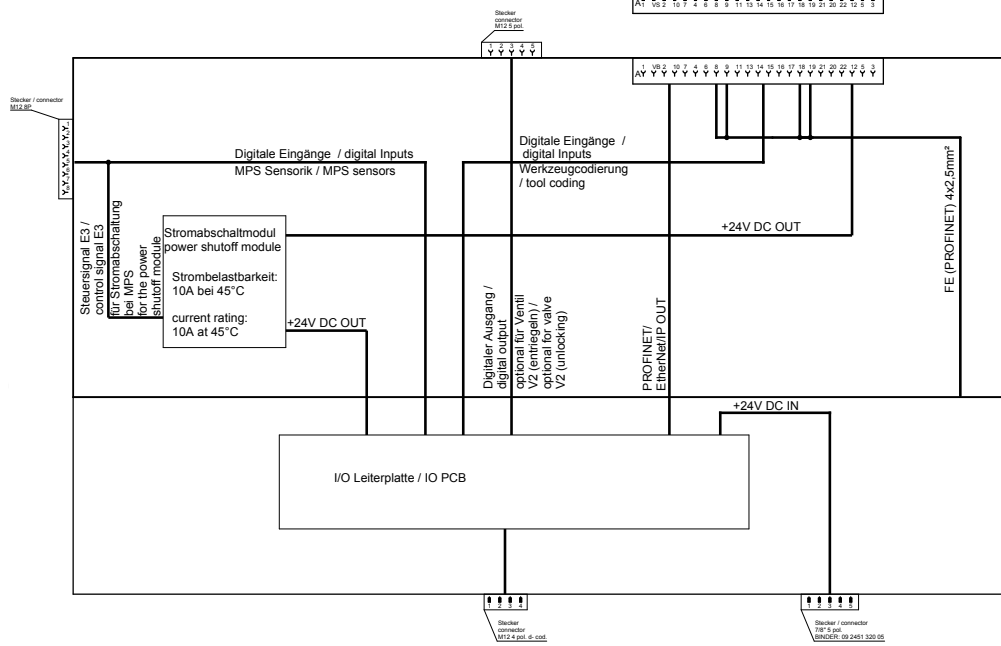

# WIRING DIAGRAMS

## ECBK\* – Electrical module MultiDNet-R

iii.1

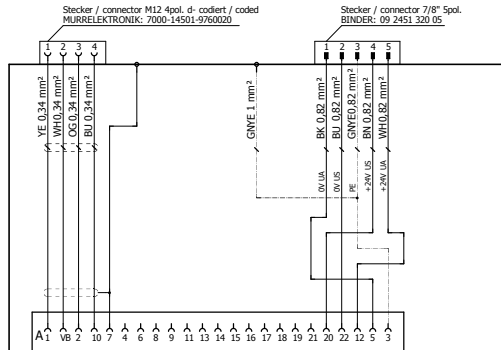

iii.2

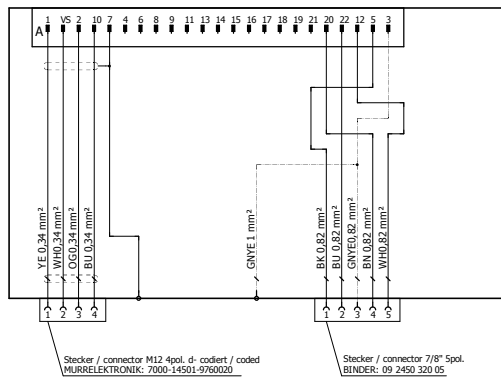

## ECBL\* – Electrical module MultiDNet-R

iii.1

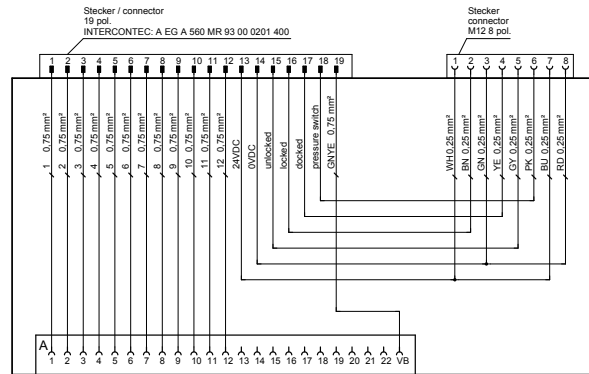

iii.2

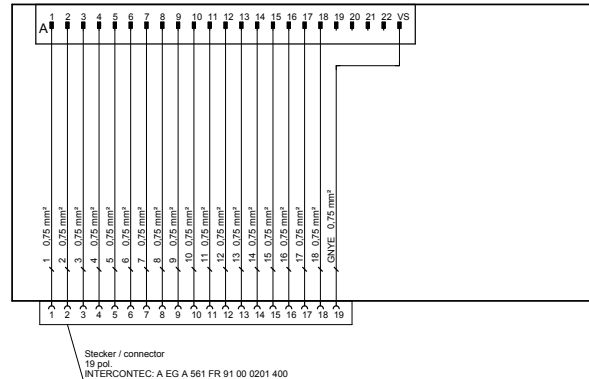

\* Depending on the connection cable used, the max. number of poles that can be assigned may be reduced when assembling the connection plug. The connection cables are not included in the scope of delivery.



# ECBI\* – Electrical module MultiDNet-R

ill.3

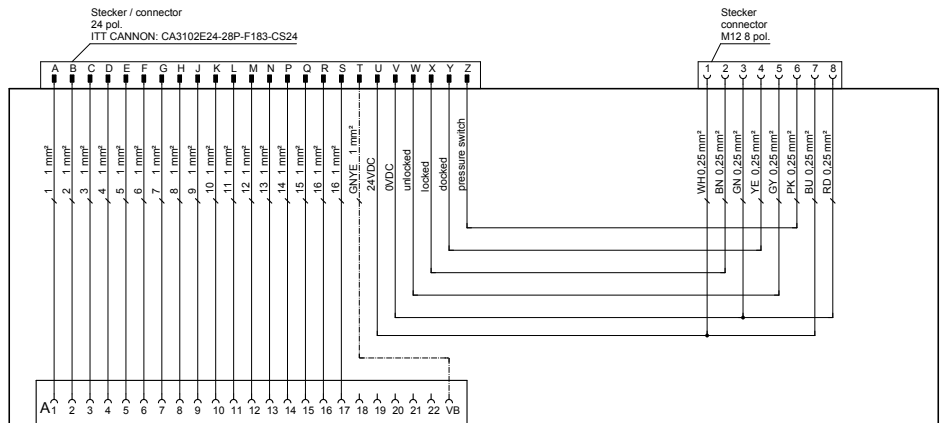

ill.4

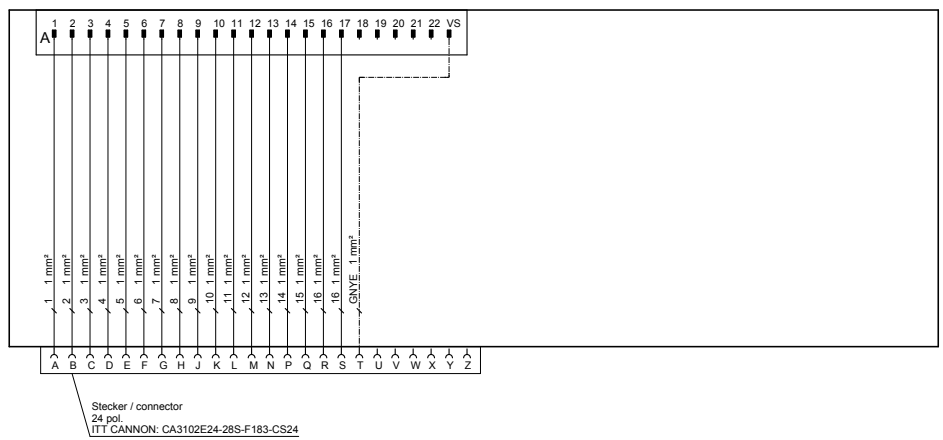

# ECBB\* – Electrical module MultiDNet-R

ill.5

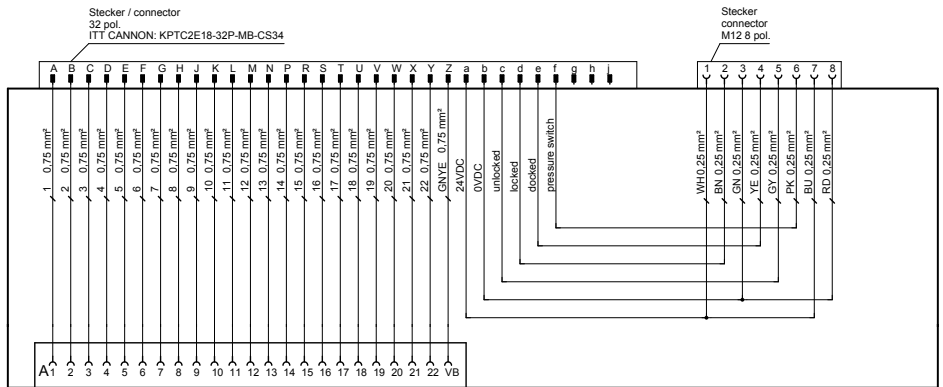

ill.6

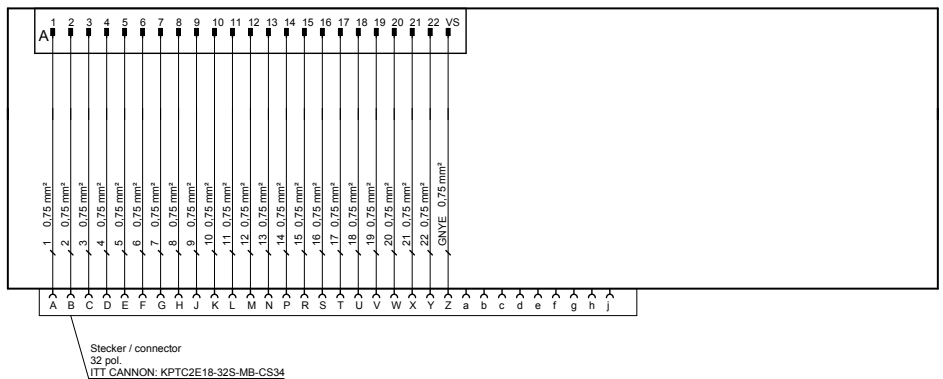

\* Depending on the connection cable used, the max. number of poles that can be assigned may be reduced when assembling the connection plug. The connection cables are not included in the scope of delivery.

# WIRING DIAGRAMS

## ECBM\* – Electrical module MultiDNet-R

iii.1

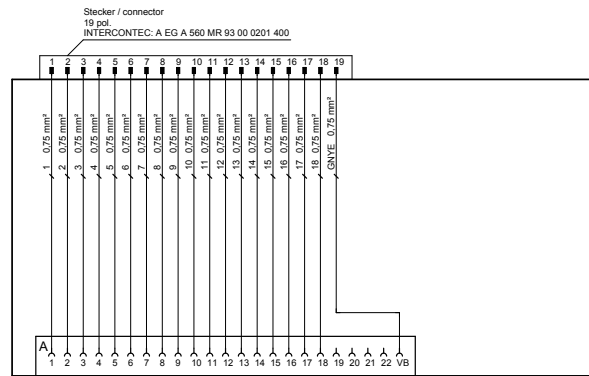

iii.2

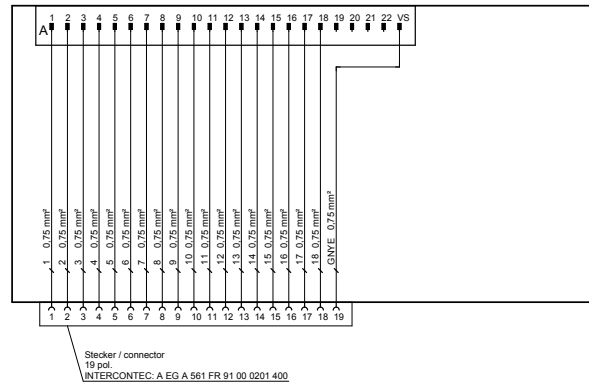

\* Depending on the connection cable used, the max. number of poles that can be assigned may be reduced when assembling the connection plug. The connection cables are not included in the scope of delivery.

# ECBA\* – Electrical module MultiDNet-R

ill.3

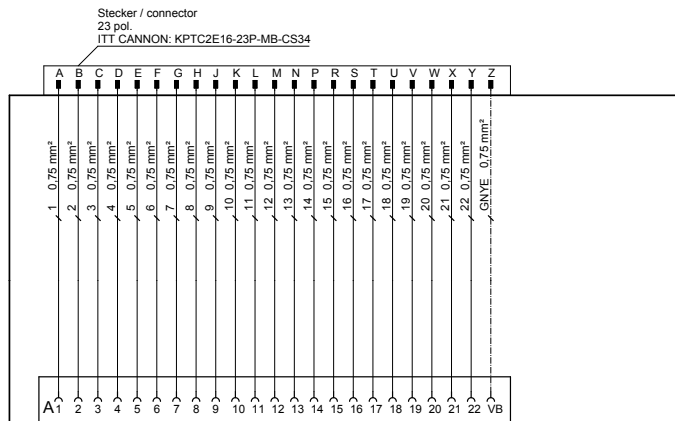

ill.4

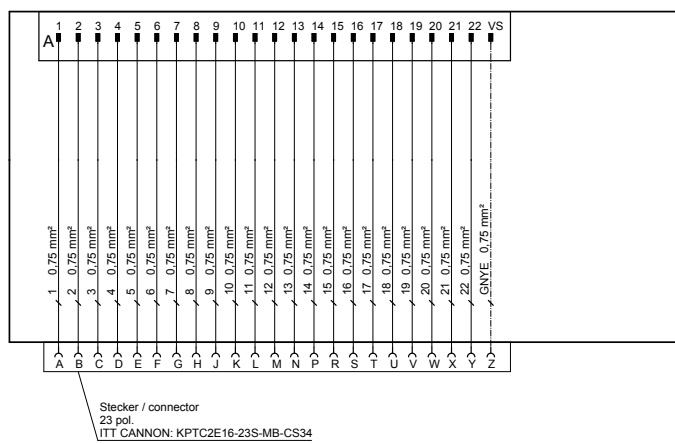

# ECBD\* – Electrical module MultiDNet-R

ill.5

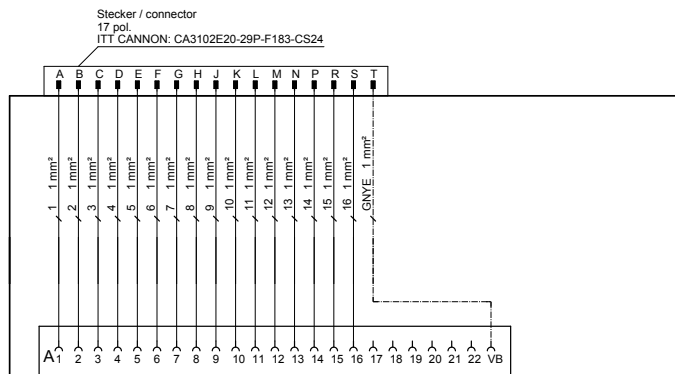

ill.6

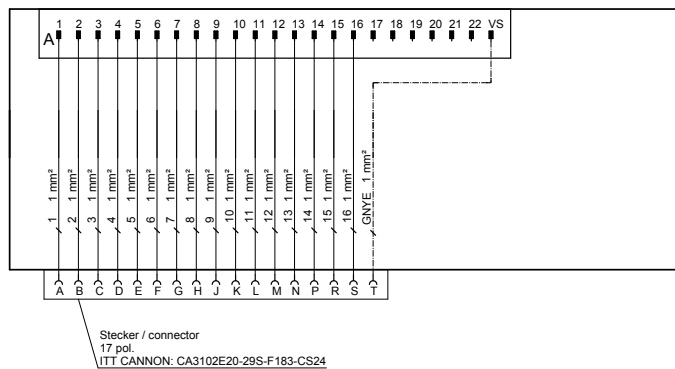

\* Depending on the connection cable used, the max. number of poles that can be assigned may be reduced when assembling the connection plug. The connection cables are not included in the scope of delivery.

## WIRING DIAGRAMS

### ECBC\* – Electrical module MultiDNet-R

iii.1

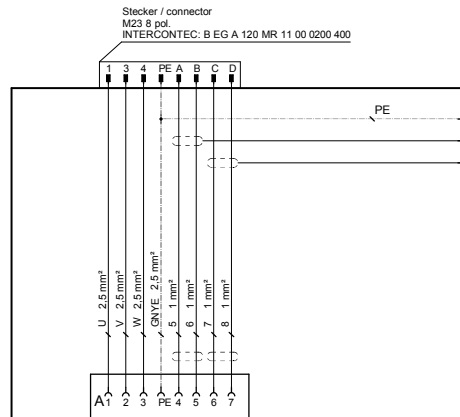

iii.2

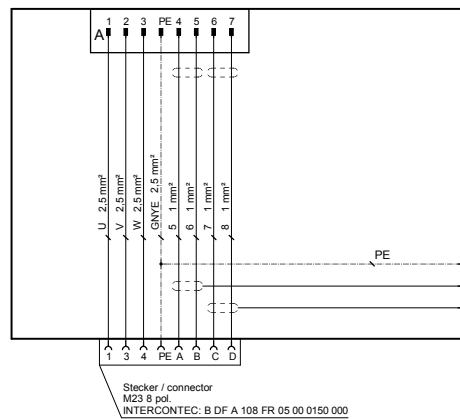

### ECBF\* – Electrical module MultiDNet-R

iii.3

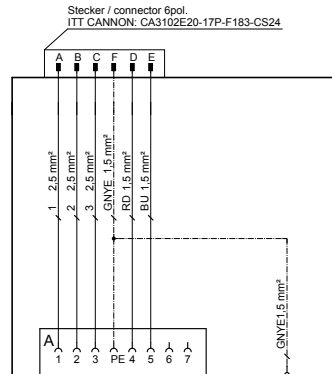

iii.4

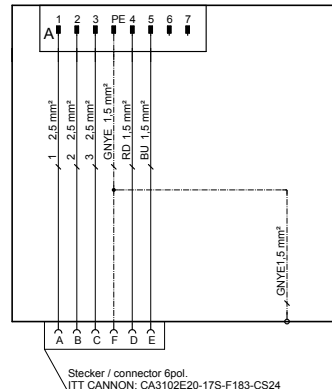

\* Depending on the connection cable used, the max. number of poles that can be assigned may be reduced when assembling the connection plug. The connection cables are not included in the scope of delivery.

PNEUMATIC DIAGRAMS

VU01 – Valve assembly

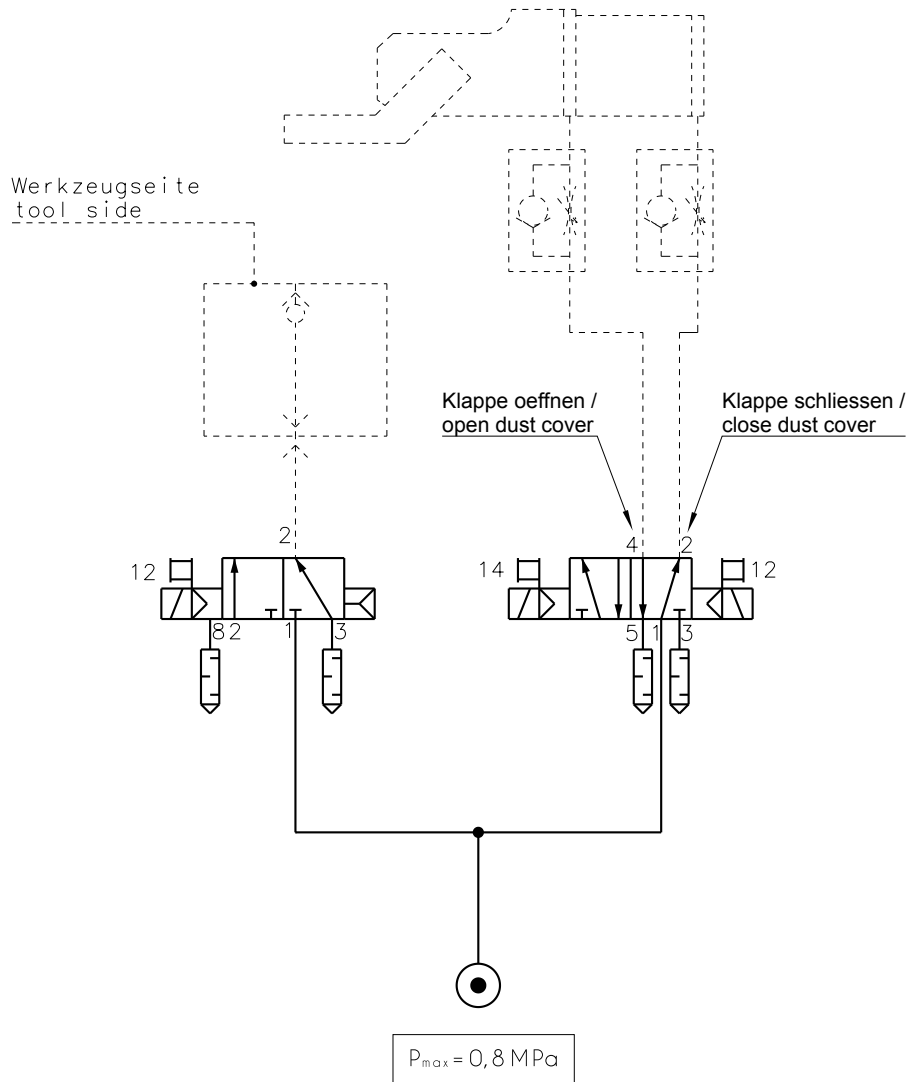



● Stäubli Units    ○ Representatives/Agents

# Global presence of the Stäubli Group

[www.staubli.com](http://www.staubli.com)